



JANUARY 31, 2022

DER Scenarios & Modelling Study

Presentation to TDWG

Ali Golriz

Lead, System and Sector Development, IESO

Study Objectives

- Investigate the impact of distribution operation of distributed energy resources (DERs) at the Transmission-Distribution (T-D) interface
 - Impacts including losses, network switching, and contingencies
- Examine bi-level participation of DERs in distribution services and IESO wholesale market services
 - E.g. at times when DERs are not needed for distribution needs and are available to meet wholesale needs
 - E.g. whether at times when DERs are needed for distribution needs they could simultaneously meet wholesale needs

Expected Study Outcomes

- Study expected to inform the IESO's DER Market Vision Project (MVP)
- Coordination between distribution and wholesale levels through market offers will be outlined
 - I.e. market offers received from DER participants in a hybrid distribution system operator (DSO) - specifically a "dual participation" - model
- Other operational coordination requirements and communications will be outlined as well

Anticipated Process & Timelines

- RFP issued in December 2021 and Electric Power Research Institute (EPRI) was selected as the consultant in January 2022
- Q2 TDWG meeting - Present detailed scenarios and methodology
- Q3 TDWG meeting - Present draft conceptual coordination protocol(s)
- Q4 TDWG meeting - Present draft final study results
- Incorporate coordination protocol(s) findings into the IESO DER Market Vision Project report by Q1 2023

Distribution Service: Non-Wires Alternatives (NWAs)

- To manage scope, the study focuses specifically on DERs providing services as NWAs to distribution infrastructure as the key near- to medium-term distribution level use case
- To enable the Study analysis, the NWAs use case is envisioned as having three service components: distribution energy, reserve, and capacity service
- In combination, the services would enable DERs to facilitate investment deferrals in traditional infrastructure

NWAs Illustrative Diagram

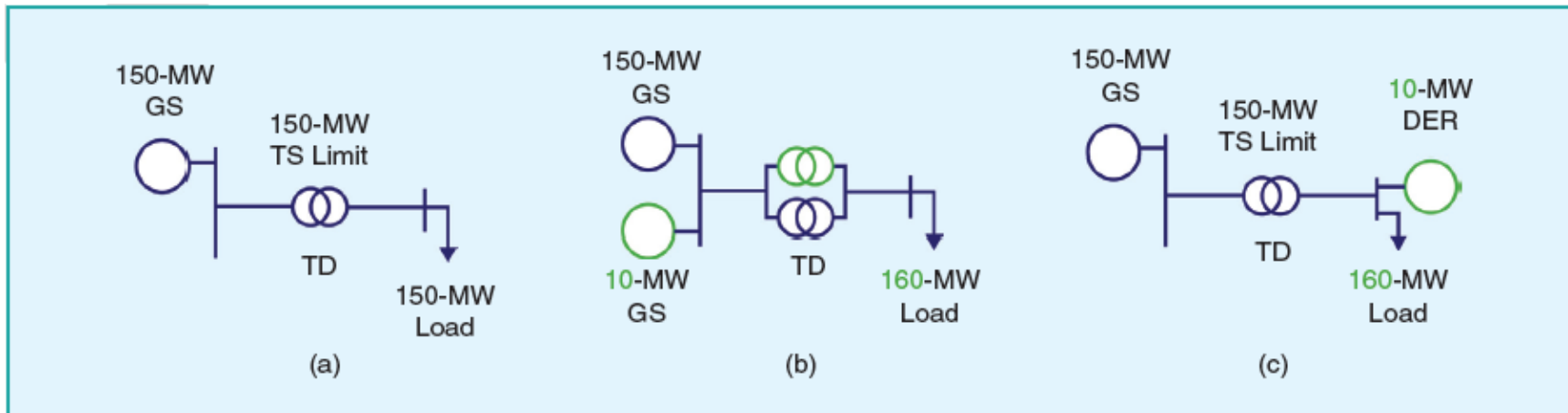
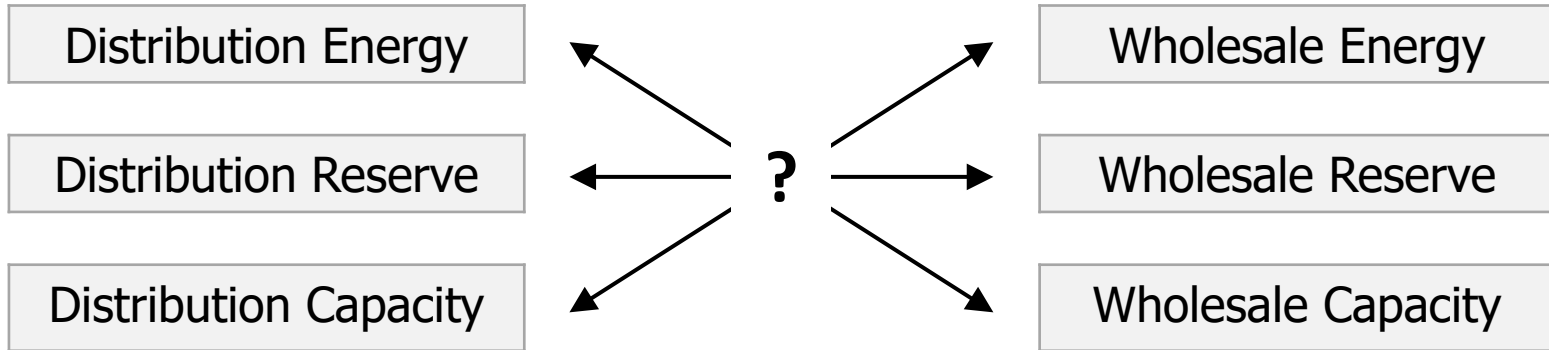

figure 1. DERs can be used as alternatives to traditional infrastructure. (a) An existing load, with the GS and transformer station (TS) at their limits. (b) Growth met with new TS and GS capacity. (c) Growth met with new DER capacity.

Distribution and Wholesale Services

- Study seeks to examine DERs providing energy, capacity, and reserve at both the distribution and the wholesale levels of the electricity system
- In particular, the Study will focus on scenarios where a DER can provide:
 - wholesale-level services or distribution-level services separately
 - distribution- and wholesale-level services simultaneously
- Multi-service DERs could potentially provide capacity-differentiated, time-differentiated or simultaneous services
- Focus of investigation will be the potential for simultaneous services provision of at both levels, allowing for service and revenue “stacking”

Distribution and Wholesale Services (continued)



Proposed Analysis Framework

The analysis framework will generally be applied to each of the scenarios investigated and proposed to involve:

- Power flow: are DERs' output deliverable to the T-D interface?
- Market offers: how should wholesale market offers be structured?
- Coordination: what are additional data exchanges/communications?
- Processes: identify the operational processes at a conceptual level
- Discussion: what are other considerations to bear in mind, e.g. in impact assessments?

Power Flow Modelling Methodology

- Steady-state power flow modelling of two standard IEEE systems and the demonstration area of the York Region NWA Demonstration Project
- A mix of DER types will be allocated to the network models and load will be adjusted to manufacture various sub-scenarios
- The power flow modelling will inform the deliverability/impact of the DERs' output at the T-D interface, which in turn will inform the approach to market offers, value stacking potential, and coordination required

Draft Proposed Scenarios for Analysis

- Five main scenarios are proposed to be investigated:
 - Wholesale energy dispatch
 - Distribution override

And for DERs being used as NWAs to distribution infrastructure:

- Distribution energy service
 - Distribution reserve service
 - Distribution capacity service
- These will be expanded upon in the upcoming slides

Wholesale Energy Dispatch

- Investigates the participation of DERs in the wholesale energy market and their impact at the T-D interface
 - In this scenario, there are no distribution system violations and DERs can operate as per the wholesale dispatch
 - Intended to be the “base case” and set foundation for the other scenarios
- How material are losses at the T-D interface? Should the impact of losses be assessed in (near) real-time?
- How should distribution feeders with multiple T-D nodes as well as network reconfiguration be considered?

Distribution Override

- Investigates the participation of DERs in the wholesale energy market considering potential for distribution system violations
 - E.g. dispatch may be “overridden” by the distributor because DERs are in an export-constrained area of the distribution system
 - Override conditions may be identified at different times in the wholesale market/dispatch process
- What are the various distribution override conditions and circumstances?
- How big of a concern (or common of an event) is DSO override today and how is that expected to change in coming years?
- What are the coordination protocols associated with override?

Distribution Energy Service

- Investigates DERs being called upon by the distributor due to an area of the distribution system being import-constrained
 - I.e. when distribution load peaks and there is insufficient network capacity to deliver energy from the bulk system to fully meet local needs, then DERs operate as NWAs
 - “Distribution energy service” for the purposes of the study refers specifically to the above circumstance
- Are DERs technically capable of providing wholesale energy service and/or wholesale reserve service when in an area of the distribution system that is import-constrained?

Distribution Reserve Service

- Investigates the use of DERs by the distributor as reserve for potential distribution system contingencies
 - I.e. if the distribution system is import-constrained and DERs are called upon, but some unexpectedly become unavailable, the distributor would make use of reserve DERs
 - When the contingency described above occurs, the reserves must be provided by DERs that are downstream of the constraint
- Are DERs used for distribution reserves service technically capable of providing wholesale reserve service when in an area of the distribution system that is import-constrained?

Distribution Capacity Service

- Investigates DERs being enrolled or contracted to be available to the distributor for use as NWAs to distribution infrastructure
 - I.e. if there is bi-level participation, DERs would need to be available when distribution system is expected to be import-constrained as well as when resource supply is expected to be limited at the bulk level
 - Will need to explore counterfactuals (i.e. what would bulk level capacity needs be if not for the DERs used as NWAs)
- Under what circumstances would DERs be technically capable of providing capacity service at both distribution- and wholesale levels?

Next Steps

- Receive feedback from the TDWG on today's materials
- Initiate the Study with consulting team and start fleshing out the scenarios, refining the analysis methodology, and building out the power flow models
- Present detailed scenarios and methodology at the Q2 TDWG meeting

Discussion & Feedback

- Do the analysis methodology and scenarios make sense? Are there other relevant analyses worth undertaking or other scenarios to explore?
- What are the various distribution override conditions and circumstances? How big of a concern (or common of an event) is DSO override today and how is that expected to change in coming years?
- What practices would LDCs employ if DERs are unavailable to meet NWA needs (besides using reserve DERs)?
- How does distribution automation impact the issues outlined?

Discussion & Feedback (continued)

- Any other comments or recommendations as we initiate this work?
- Please provide written feedback to innovation@ieso.ca by February 14

Thank You

ieso.ca

1.888.448.7777

customer.relations@ieso.ca

engagement@ieso.ca



[@IESO Tweets](https://twitter.com/IESO)



facebook.com/OntarioIESO



linkedin.com/company/IESO