

TDWG Presentation

B1 – Process & User Journey Map

February 16, 2024 Draft



Deck Roadmap

1. Functional Assessment Deliverable Overview
2. Review of high-level DSO architecture as presented at December TDWG meeting
3. Overview of DSO models covered by the User Journey Map deliverable
 - § Neutral Market Facilitator
 - § Total DSO
 - § Dual Participation DSO
4. Guide to Reading the User Journey Document
5. User journey maps

01

B1 - Deliverable Overview



B1 Functional Assessment - Deliverable overview

The B1 deliverable focuses on the identification of operational and functional requirements, internal resourcing and capability development, and the associated costs that must be taken on by LDCs as they transition into DSOs

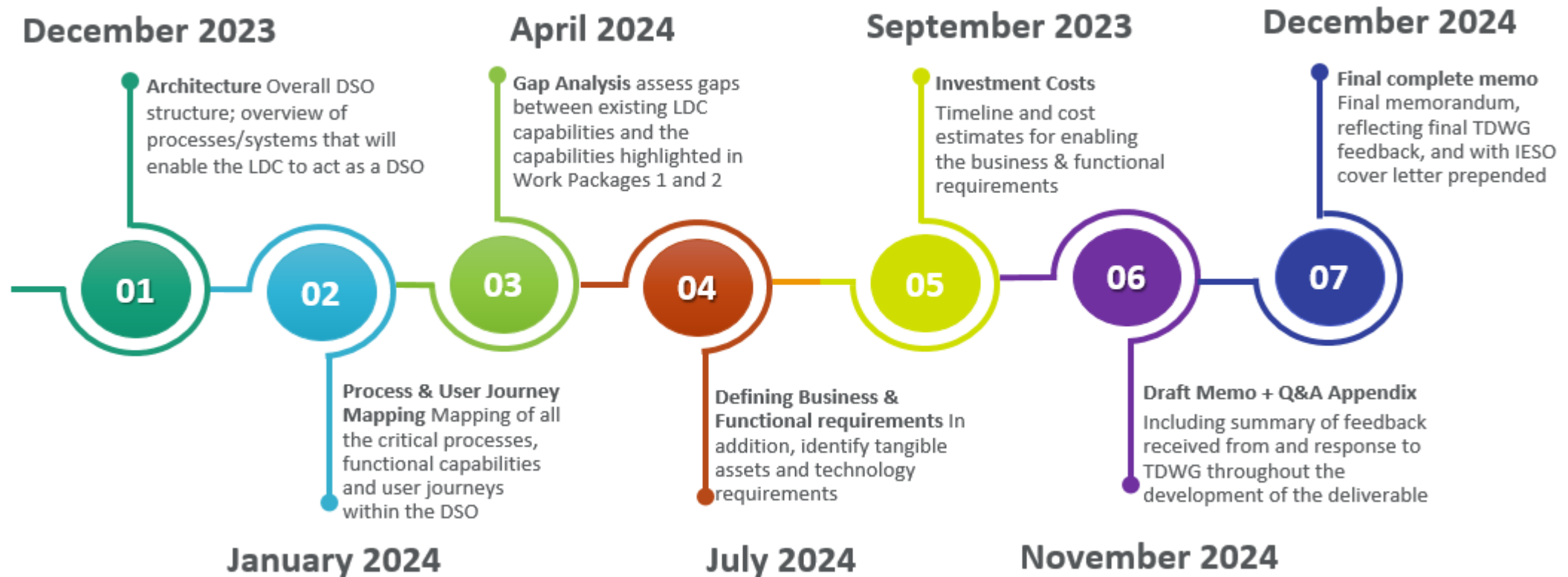

Deliverable [B1]: Functional Assessment – Work Packages

No	Name	Description	Outputs
1	Architecture	Define the overall DSO structure and an overview of the processes/systems that will enable the LDC to act as a DSO	A deck outlining overarching DSO structure (flowchart/map) and required systems for each model (high-level)
2	Process and user journey mapping	Mapping of all the critical processes, functional roles and user journeys within the DSO	A deck outlining the critical processes and user journeys for each model
3	Gap analysis	Gap analysis that will assess the gap between the existing LDC capabilities and the capabilities highlighted in Work Packages 1 and 2	A document outlining the gap analysis for each model
4	Defining business and functional requirements	Defining the business and functional requirements. In addition, identify tangible assets and technology requirements	A spreadsheet outlining the key business and functional requirements for each model
5	Investment Costs	Timeline and cost estimates for enabling the business and functional requirements	A spreadsheet with a costing breakdown for each model

02

Recap DSO Architecture Review



Proposed DSO Architecture – Operational Elements

Elements required for day-to-day DSO operation

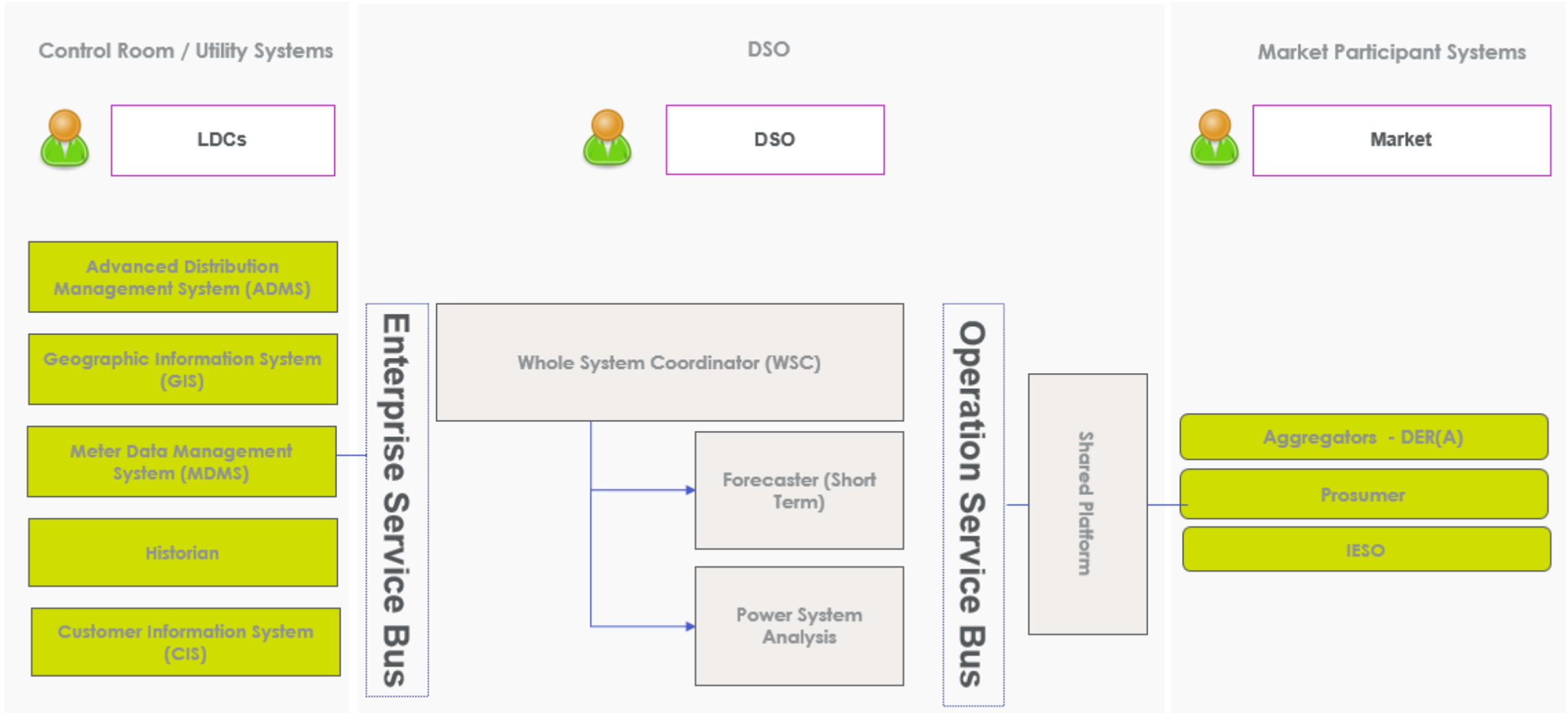

Legend

Net new functionality

Enhancing Existing Capabilities

Existing Systems

Proposed DSO Architecture – Planning Elements

Elements required for longer-term decision making and coordination

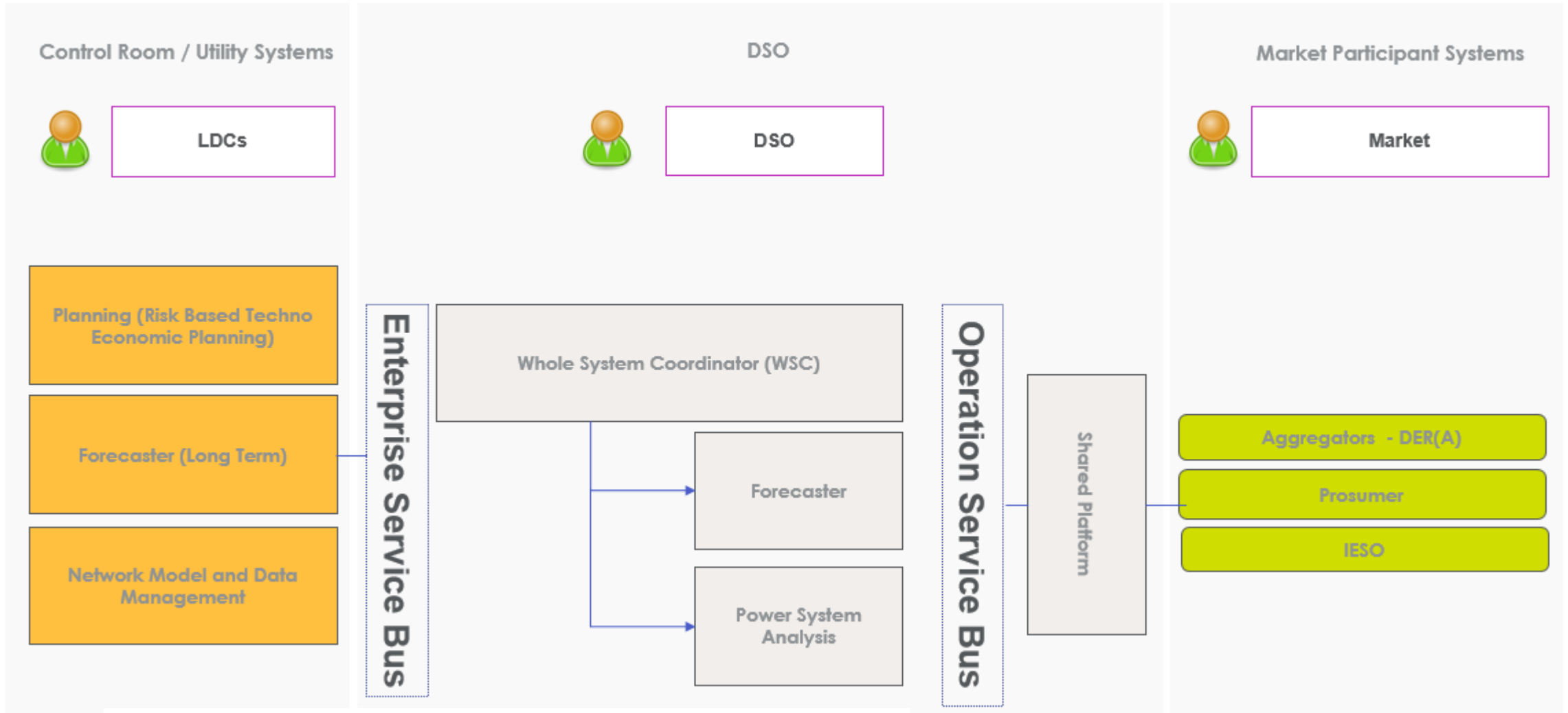

Legend

Net new functionality

Enhancing Existing Capabilities

Existing Systems

Architecture Definitions (1/3)

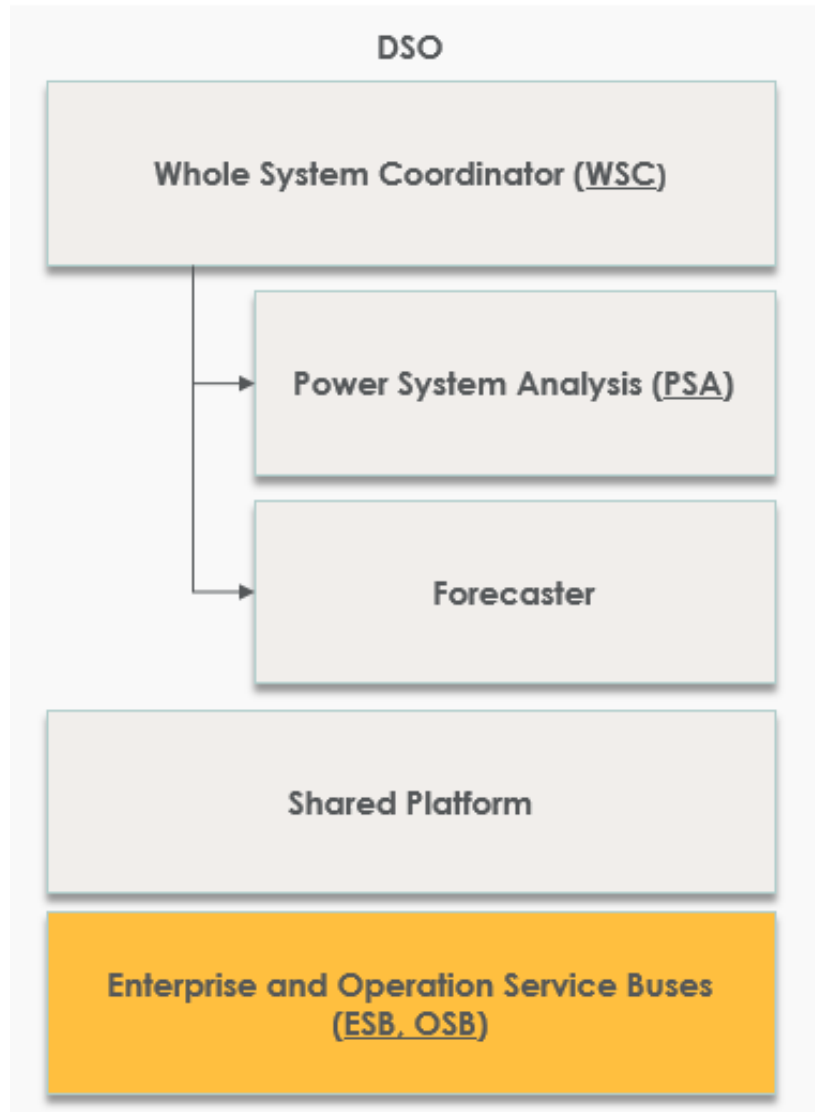

Whole Distribution System Coordinator (WDSC) is the “brain” of the DSO’s operation (1)

- Responsible for conducting the constant power flow analyses of the network’s ever-changing state
- Determines grid needs in terms of physics and electromagnetics, and computes the DER(A) quantities that could address them (e.g. DER-supplied energy additions or reductions, or in future use cases, reactive power)

Power System Analysis (PSA) is the DSO’s analytical engine

- Determines system conditions/needs and evaluates responses based on the ability to at minimum run a 3 phased unbalanced security constrained power flow or optimal power flow (snapshot and time series) with the inputs being network model, load and generation forecast, and asset demographics.
- The objective functions would be technical (e.g. voltage conservation, loss minimization, cost minimization).
- The PSA must conduct this analysis in relevant market/market zone (includes all the feeders in that zone at all voltage levels) within a 5-10 minute window.

Forecaster is an engine that can generate a nodal and system wide load and generation forecast at different time granularity levels as needed.

Market/Shared Platform (M/SP) is an exchange platform that helps facilitates transactions, enables information sharing, and supports an ecosystem of market services. It is external to utility’s control room infrastructure. (2)

- Communicates distribution grid and potential wholesale market needs to the market where DER(A)s can make offers
- Enables market-clearing functions, including registering participating DER(A)s, tracking contractual obligations, bids/offers,
- Shares system and dispatch information with market participants and potentially the IESO, enabling each party to make informed decisions

Enterprise and Operation Service Buses – Enterprise Service Bus is an integrated solution that provides fundamental interaction and communication services for complex software applications via an event-driven and standards-based messaging engine, or bus, built with middleware infrastructure product technologies. This is the ideal integration approach, however, LDCs could undertake other approaches that provide system separation and integration.

1. Whole Distribution System Coordinator – UK, Scottish and Southern Energy Network’s TRANSITION Project
2. Shared Platform – TDWG B3 Deliverable

Architecture Definitions (2/3)

LDCs

Advanced Distribution Management System (ADMS)

Advanced Distribution Management System (ADMS)

- Combines advanced distribution management system (DMS) analysis to optimize network operations, a field-proven SCADA system to address modern cybersecurity requirements, and an embedded outage management system (OMS) for improved resilience and reliability.

Geographic Information System (GIS)

Geographic Information System (GIS)

- Provides a map-centric, intuitive way to model, design, maintain, and manage facility and land-based information. This enables collaboration, network management and analytics to improve performance for utilities.

Meter Data Management System (MDMS)

Meter Data Management System (MDMS)

- Responsible for cleansing, calculating, providing data persistency, and disseminating consumption and event data obtained from meters installed on delivery points.
- The key data being tracked is metered commodity consumption and meter-related events, regardless of the type of commodity metered, type of meter, communication technology or collection device.

Historian

Historian

- is an integrated portfolio of software to collect, store, view, analyze, and share operational data with users within and beyond the enterprise.

Architecture Definitions (3/3)



Customer Information System (CIS)

- A CIS application serves as the backbone for the LDC's customer data management with a focus on handling customer data, billing, and consumption information

Planning (Risk Based Techno Economic Planning) (3)

- Planning toolset(s) that will allow planners to pivot away from worst case scenario assessments to an approach that captures the economic and technical details of operational realities within planning
- Planning toolset(s) that would allow planners to quantify and evaluate potential investment scenarios (network reconfiguration, flexibility procurement, expansion strategies, and non-wires alternatives) based on asset benefits by type, capacity, location, and time. This planning tool(s) will be able to determine the different cost components of each potential solution, assess their technical viability at addressing system needs, and compare the solutions to reveal the lowest cost and/or highest customer value options.

Forecaster (Long Term)

- Forecaster is an engine that can generate a nodal and system wide load and generation forecast at different time granularity levels (time series planning granularity)

Network Model and Data Management

- Network model and data management capability focused on continuously maintaining the accuracy and integrity of network models and all associated data that will support the function of all system

3. Planning (Risk Based Techno Economic Planning): UK, Scottish and Southern Energy Network's MERLIN project

03

Overview of DSO Models Covered in High-Level User Journey



Overview of DSO models Covered

1. Dual DSO Model (DP-DSO)

Under this model, DER/As participate directly in the wholesale markets and are dispatched and optimized by the TSO to meet bulk system needs. The DSO dispatches DER/A to meet local system needs. DER/A are responsible for communication requirements associated with DER/A dispatching, curtailment, bids and offers between all parties.

2. Total DSO Model (T-DSO)

Under this model, the DSO is the sole counterparty for both wholesale and distribution-level services. DER/A participate directly with the T-DSO and the T-DSO submits a single wholesale market bid/offer that reflects the combined bids and offers of all participating DER/A within the service area. The T-DSO would be subject to the same market rules, obligations, and penalties that apply to all wholesale market participants.

3. Neutral Market Facilitator Model (NMF)

This model is similar to the T-DSO model with **two key differences**. **The DSO would not be acting as an aggregator or market participant**, it would only facilitate the participation of DERs within the service area. The DER/A would maintain the commercial relationship with each market operator. The DSO would be responsible for dispatching DER/A based on local and bulk needs, communicating all information to the TSO, as well as providing measurement, verification, and settlement. **The DSO will be responsible for optimizing distribution grid operations** to support DER participation and limit curtailment.

Comparison of T-DSO versus NMF

	Total DSO	Neutral Market Facilitator
Distribution System Optimization	<p>Not required</p> <p>As defined by the processes in the EPRI report, T-DSO does not optimize its operations to facilitate DER market participation. It is purely an evaluation of whether the LDC can accommodate the DERs, there is no requirement to optimize to attempt to reduce the impact of curtailment DER.</p>	<p>Required</p> <p>The DSO is responsible for optimizing distribution grid operations to support DER participation and limit curtailment. This is what makes the LDC a facilitator.</p>
Market Participation	<p>Market Participant</p> <p>T-DSO submits a single wholesale market bid/offer that reflects the combined bids and offers of all participating DER/A within the service area. The T-DSO would be subject to the same market rules, obligations, and penalties that apply to all wholesale market participants.</p>	<p>Market Facilitation and Neutrality</p> <p>The DSO does not act as a market participant and is not a party to any commercial agreement (e.g., acting as an aggregator). The DER/A would maintain the commercial relationship with each market operator.</p>

DSO Models Comparison

	Total DSO	Dual Participation	Neutral Market Facilitator
1	DER/A submits info to DSO	DER/A submits info to DSO	DER/A submits info to DSO
2	DSO assesses DER/A limits and NWA service selection	DSO assesses DER/A limits and NWA service selection	DSO assesses DER/A limits, optimizes system to enable maximum MWs and NWA service selection
3	DSO communicates DER/A limits and NWA service to DER/A	DSO communicates DER/A limits and NWA service to DER/A	DSO communicates DER/A limits and NWA service to DER/A
4	DSO aggregates bids and submits bids into IESO WSM	DER/A submit bids into IESO WSM	DSO facilitates and channels DER/A bids into the WSM through a singular pathway and point of integration
5	IESO clears market and dispatches DSO	IESO clears market and dispatches DER/A	IESO clears the market and sends dispatch to DSO
6	DSO disaggregates and dispatched DER/A	DER/A informs DSO of dispatch.	DSO assesses live system and dispatches DER/A
7	DSO may limit DER(A) after dispatch and DSO informs DER(A) and IESO	DSO may limit DER(A) after dispatch and DSO informs DER(A) and DER(A) informs IESO	DSO may limit DER(A) after dispatch and DSO informs DER(A) and IESO

High Level User Journey

The high-level user journey describes the story followed through the DSO by the different stakeholders, from system condition, and identification of a need up to the completion of all decisions, actions, and transactions. This chapter presents the user journey and the use cases in the journey, while the next chapter illustrates it with an example to facilitate its understanding.

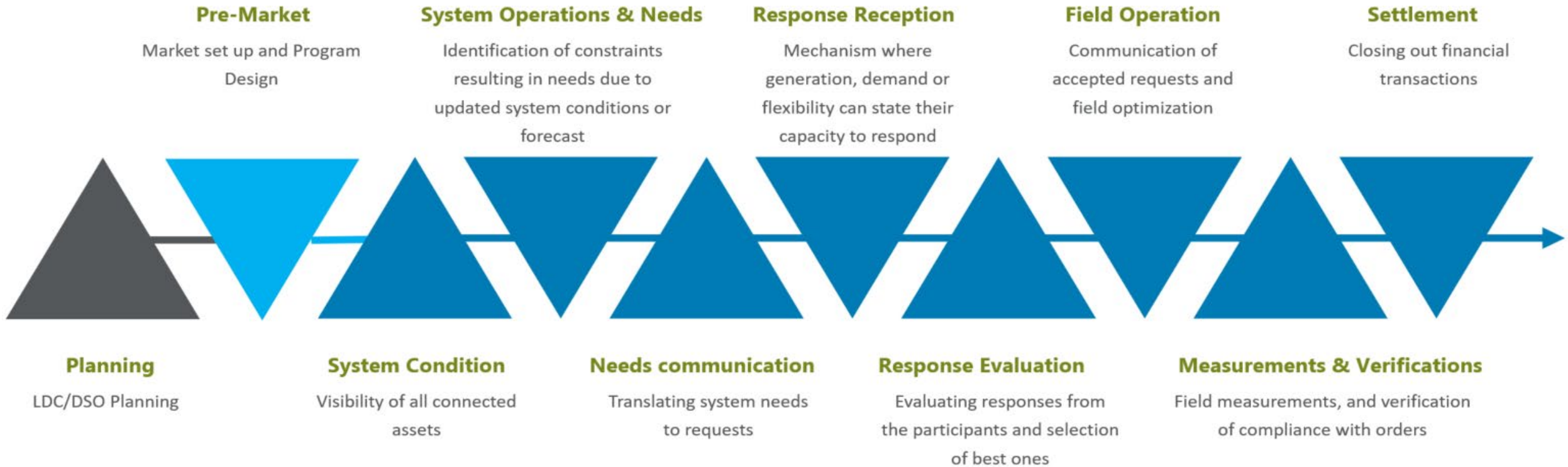

High Level User Journey

Journey Step	Description
Planning	LDC planning to determine long term system needs and define the type of services for procurement
Pre-Market	This is a pre-operational stage. System operators upload and define network model and boundaries. Assets are registered on network to specific participants and login details are generated and disseminated to users.
System Condition	This is the first operational stage in the use case. This stage requires that the digital energy platform receives information about the current and future state of the system. This could include but isn't limited to, electrical measurements on lines and at substations (real power, reactive power, active power, current, etc), generation forecasts and commitment from assets, forecasted load, state of charge of large scale batteries, an asset reliability metric, etc.
System Operation and Needs	Whole System Distribution Coordinator ingests the system condition data and identify future system issues that need to be resolved (i.e. supply, demand imbalance, a thermal constraint of a line/cable, a risk of voltage deviating outside of the operational limits).
Needs Communication	These needs are translated into products or services which the system operators then posts on the Market/Shared Platform to procure.
Needs Response and Reception	Participants use the Market/Shared Platform to post their 'responses' which include how much power and for what duration participants can increase/decrease generation or load and for what price they are willing to do this for.
Response Evaluation	The WDCSC calculates a techno-economically optimal dispatch schedule (utilizing an OPF) for the system to solve the System Need, while minimize cost and risk of non-delivery.
Field Operation	The optimal dispatch is communicated with participants either through dispatch request or APIs.
Measurement and Verifications	Post-dispatch metered data is collected to verify actual generation and consumption
Settlement	Metered data is compared to contracted volumes and prices to calculate payments and penalties for each participant.

04

Guide to Reading the User Journey Document



High Level Use Case Description



Identifying the objective of the use case

Objective

- X

Stakeholders engaged during the step

Impacted Stakeholder

- X

Current Use Case Under Discussion on the slide

Systems utilized in the use case

Impacted Systems

- X
- X
- X

Key data requirement to enable the operations of the use case

Data Requirements

- X

Chronological list of the steps in the use case

High Level Steps

Planning

The system associated with the step

1. X
2. X

WDSC

3. X

High Level Use Case Description

Current Use Case Under Discussion on the slide

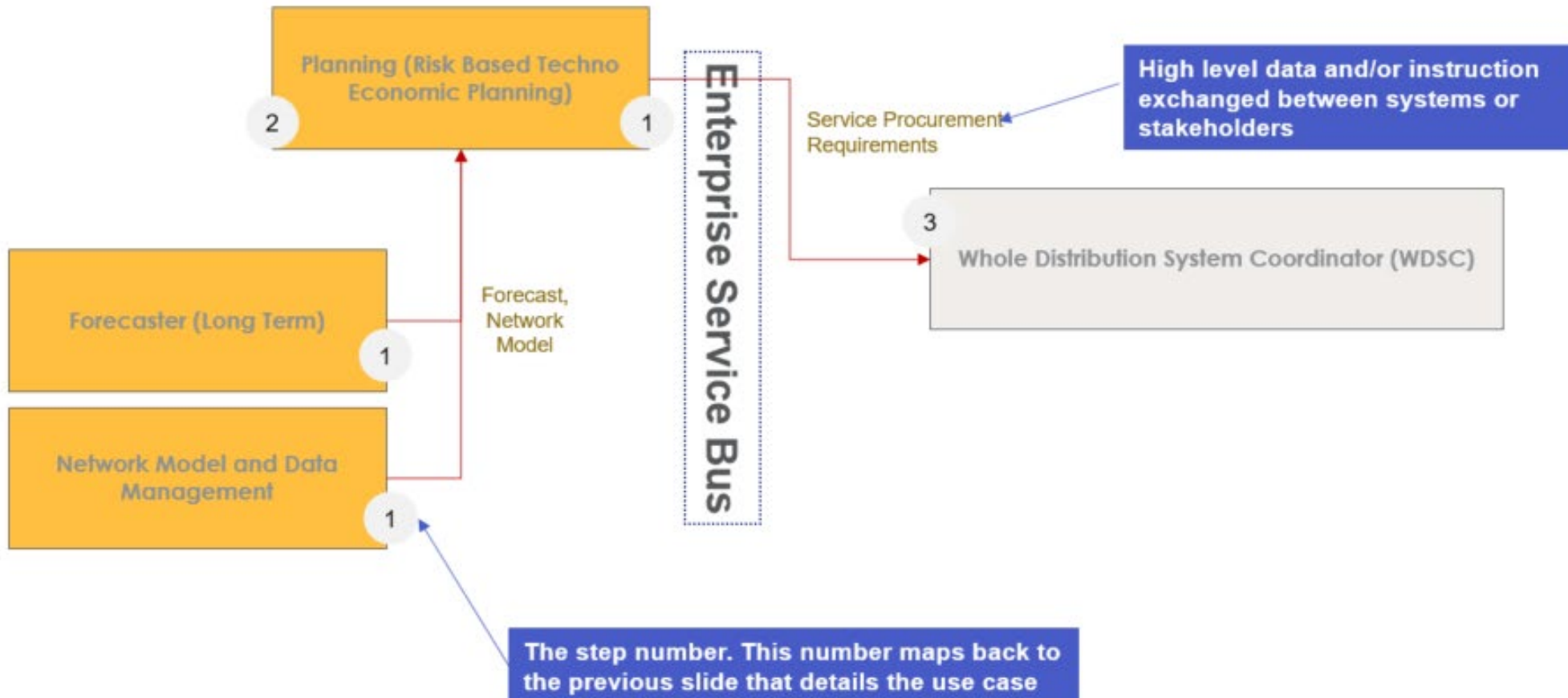

05

List of User Journeys



List of User Journeys

1. Standard Journey
 - A. Neutral Market Facilitator
 - B. Dual Participation DSO
 - C. Total DSO
2. Host LDC and Embedded LDC
3. Standard Journey without the shared platform (Neutral Market Facilitator)

06

User Journey #1A



Planning



Objective

- LDC planning to determine long term system needs and define the type of services for procurement

Impacted Stakeholder

- LDC
- IESO

High Level Steps

Planning

1. LDC System planners, through the system planning process, evaluate system needs (LDC would account for the regional planning requirements)
2. LDC System planners evaluate various solutions to address system needs.
 - Quantify and evaluate potential investment scenarios (network reconfiguration, flexibility procurement, expansion strategies, and non-wires alternatives) based on asset benefits, by type, capacity, location, and time.
 - Determine the different cost components of each potential solution, assess their technical viability at addressing system needs, comparing the solutions to reveal the lowest cost and/or highest customer value options.

WDSC

3. WDSC is updated with service procurement requirements (if that option was selected in step 2)

Impacted Systems

- Planning (Risk Based Techno Economic Planning)
- Forecaster (Long Term)
- Network Model and Data Management
- Whole Distribution System Coordinator (WDSC)
- Market/Shared Platform (M/SP)

Data Requirements

- Network Models, forecast

Planning

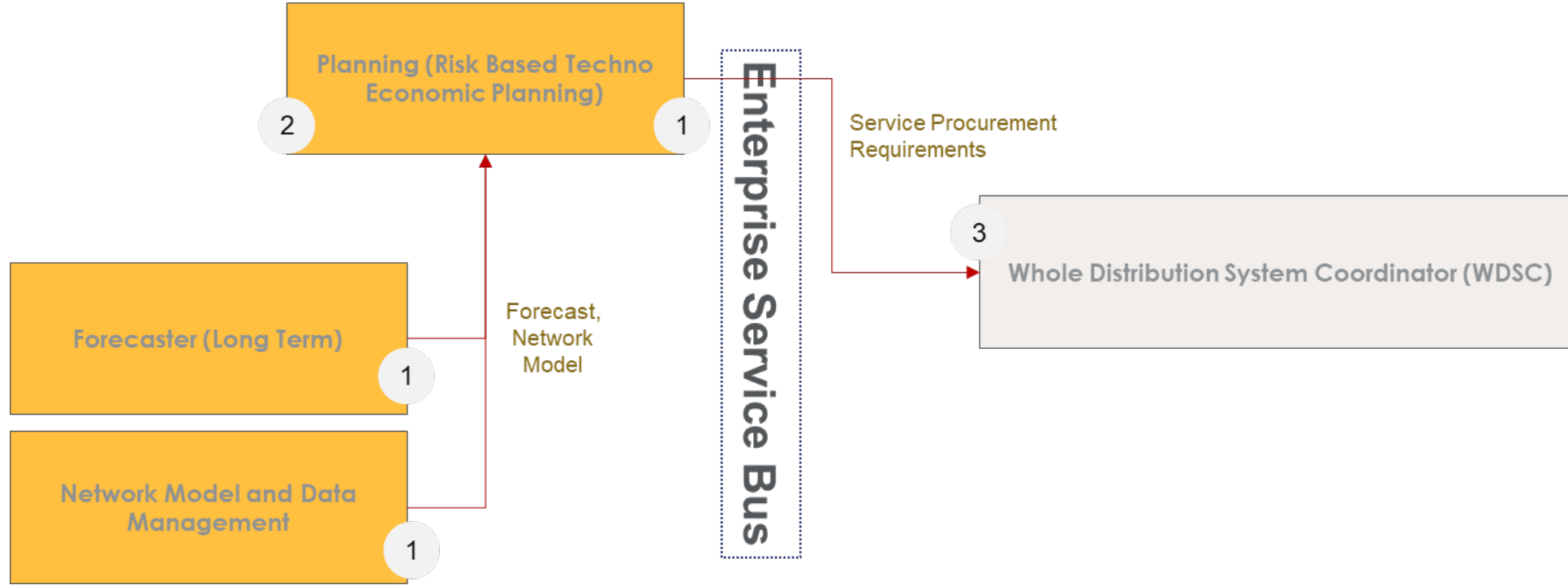
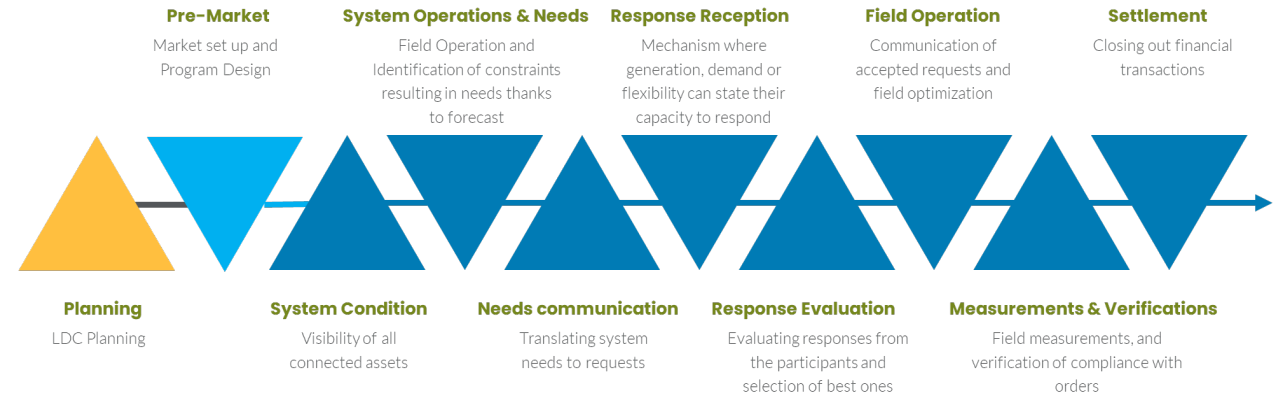

Pre-Market: Market Setup

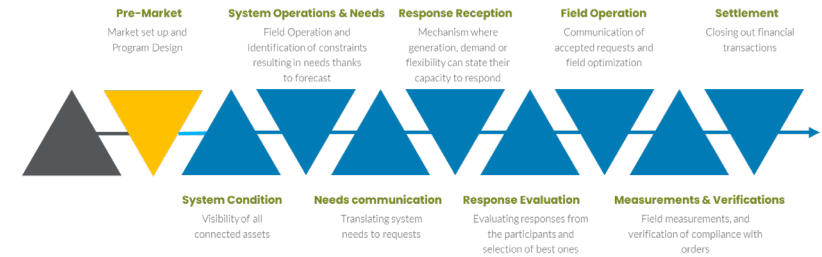

Objective

- Pre-market: Creation of market zones and service programs

Impacted Stakeholder

- IESO
- DSO
- DER(A)

High Level Steps

WDSC

1. Administrator (IESO and DSO) creates/modifies the markets zones
2. Administrator (IESO and DSO) creates/modifies the service programs
3. Administrator (IESO and DSO) Synchronises with Market/Shared Platform

M/SP

4. DER(A) views market programs by zone

Impacted Systems

- Whole Distribution System Coordinator (WDSC)
- Market/Shared Platform (M/SP)

Data Requirements

- None

Pre-Market: Participant and Energy Resource Management

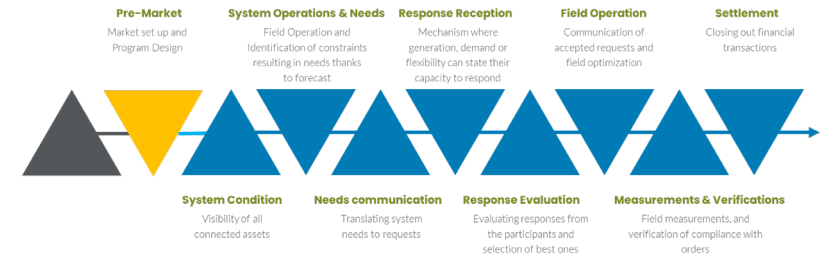

Objective

- Pre-market, setup market participants and associated assets in zone and types of services

Impacted Stakeholder

- DER(A)
- DSO

High Level Steps

M/SP

1. DER(A) registers assets and selects the type of services
2. M/SP determines eligibility (based on market operator-defined rules – defined by IESO and DSO)
3. M/SP synchronizes data with WDSC (ex: asset information, location, type of services, zone, etc...)

WDSC

4. WDSC updates Network Models and synchronizes data requirements with Power System Analysis and Forecaster

Impacted Systems

- Whole Distribution System Coordinator (WDSC)
- Market/Shared Platform (M/SP)

Data Requirements

- Asset Information (Size of service, type of service, location, connection/operational limit)

Pre-Market: Participant and Energy Resource Management

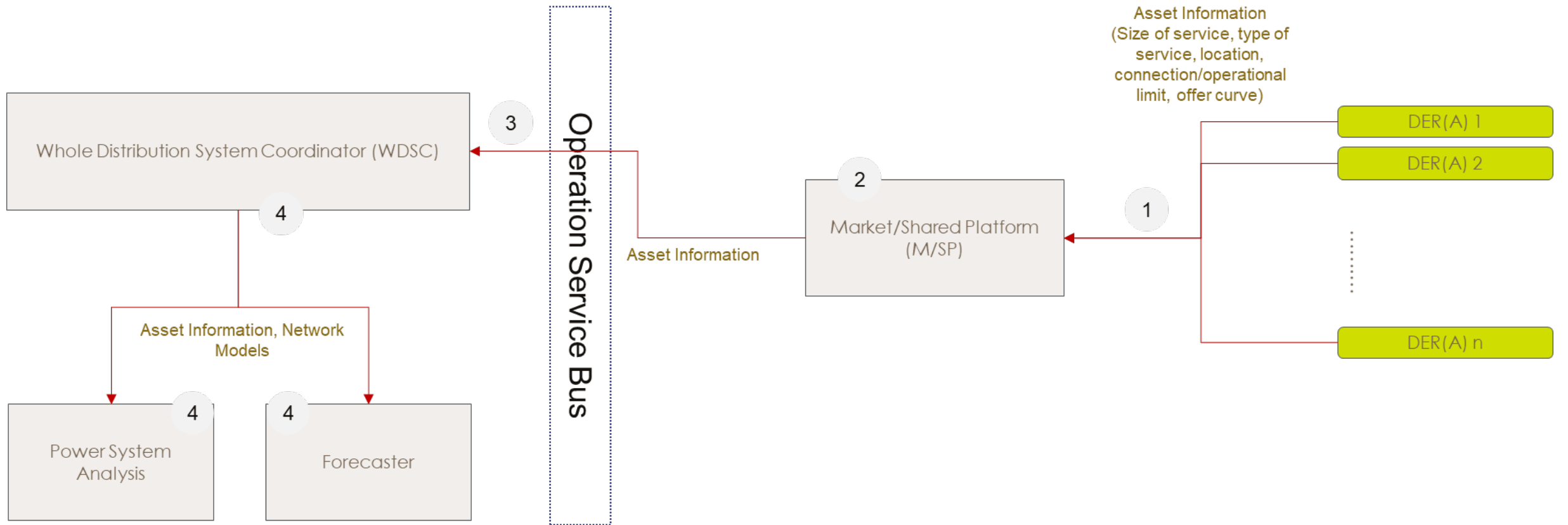

System Conditions and System Needs



Objective

- Determine system conditions and system needs

Impacted Stakeholder

- IESO
- DSO
- DER(A)

High Level Steps

M/SP

1. **DER(A)** register their contract commitments

Forecaster

2. **Forecaster** update forecast based on DER(A) contract commitments, historical telemetry, system telemetry, meter data)

WDSC

3. **WDSC** collates all necessary data (DER(A) contract commitments, load & generation forecast, network models, system telemetry)

Power System Analysis

4. **PSA** runs a time-series (for the appropriate market time frames) security constraint power flow for each of the zones to determine security of DER(A) contracts and system impacts
5. **PSA** runs a time-series (for the appropriate market time frames) security constraint power flow for each zone to determine system conditions to identify system constraints.

Impacted Systems

- Whole Distribution System Coordinator (WDSC)
- Market/Shared Platform (M/SP)
- Power System Analysis
- Forecaster

Data Requirements

- DER(A) Contract commitments, forecasts, system telemetry, network models

This can include N-1 contingency analysis and/or stochastic-based security constraint power flow

6. **PSA** runs a time-series (for the appropriate market time frames) security constraint power flow for each of the zones to determine the optimal solution to system constraints based on the registered assets (Creation of the bids)

WDSC

7. **WDSC** communicates optimal system requirements (the DSO bids) to M/SP (and potential limitations)

M/SP

8. **M/SP** informs **DER(A)** and **IESO** of any limitations placed on **DER(A)** with support information
9. **M/SP** publishes the bids

System Conditions and System Needs

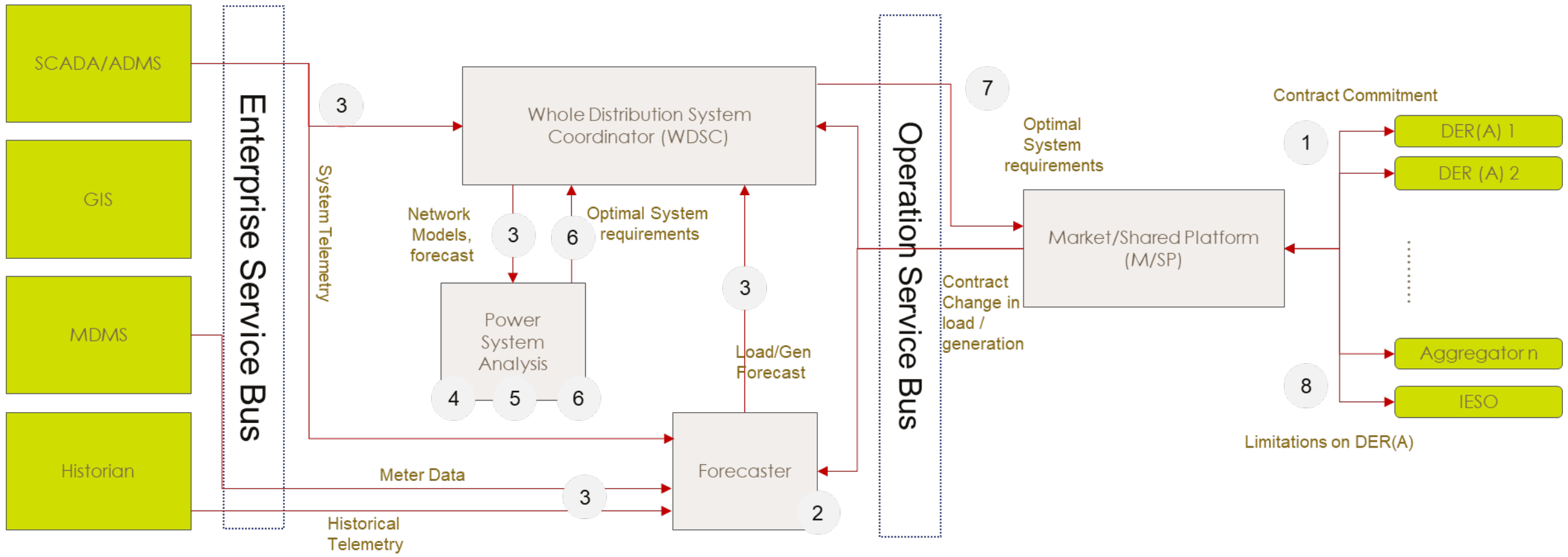

Needs Communications and Response Reception



Objective

- Communication of System Needs (DSO bids) through the Shared Platform to the market participants. Facilitating and collecting the response of the market participants

Impacted Systems

- Market/Shared Platform (M/SP)

Impacted Stakeholder

- DER(A)

Data Requirements

- “Offer Curves”

High Level Steps

M/SP

1. M/SP posting DSO system needs “bid” in the appropriate zones for each of the market time frames
2. DER(A) review the “bids” and places their “offers”. The DER(A) can create “offer curves” that would facilitate an automatic response to “bids”

Needs Communications and Response Reception

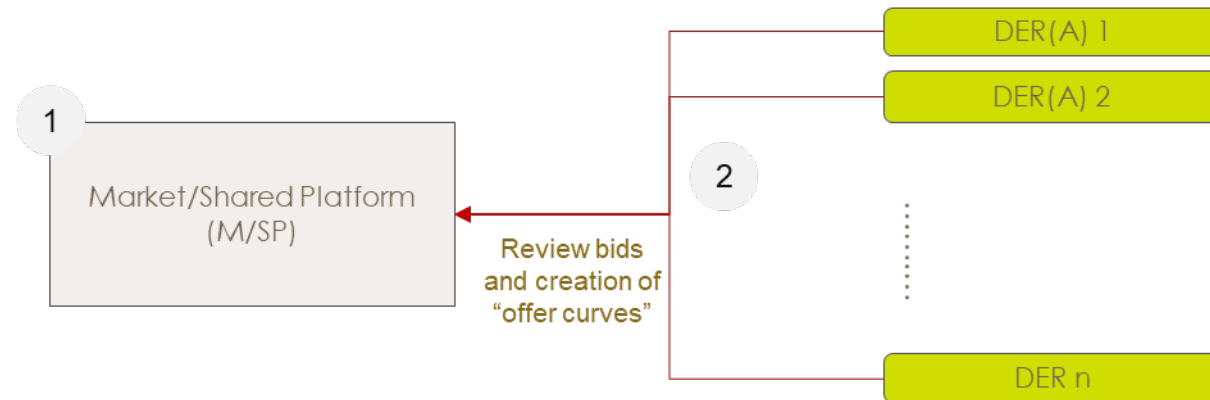

Response Evaluation



Objective

- Review response from the market and select optimal DSO market “offers”

Impacted Stakeholder

- DSO

Impacted Systems

- Whole Distribution System Coordinator (WDSC)
- Power System Analysis
- Market/Shared Platform (M/SP)

Data Requirements

- “Bids”, network models updates, system limitations or overrides from SCADA

High Level Steps

WDSC

1. *WDSC* collates all necessary data (DSO Market “bids”, network models updates from SCADA, system limitations or overrides from SCADA)

Power System Analysis

2. *PSA* runs a time-series (for the appropriate market time frames) security constraint power flow for each of the zones to determine optimal system operation based on market “bids” (select the optimal “bids”), accounting for any network topography changes and potential system limitations or overrides from SCADA. This can include N-1 contingency analysis and/or stochastic based security constraint power flow.

WDSC

3. *WDSC* communicates selected “bids” to M/SP

Response Evaluation

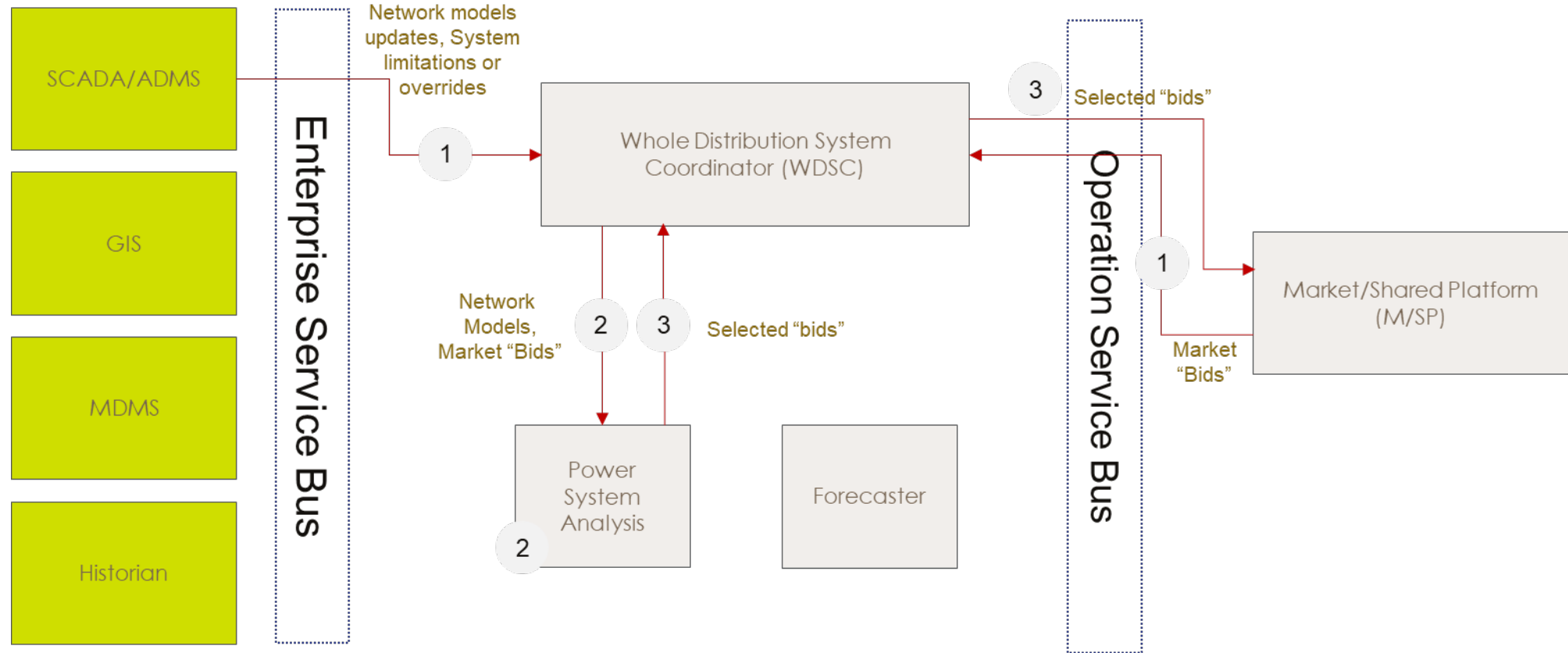
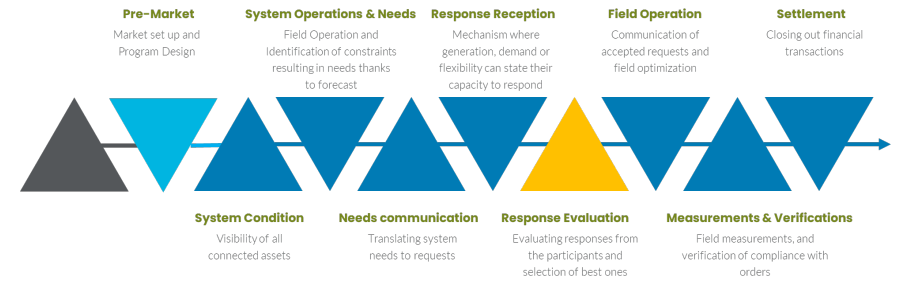

Field Operation - Selection



Objective

- Communication of selected DSO “bids” to the market

Impacted Systems

- Market/Shared Platform (M/SP)

Impacted Stakeholder

- DER(A)

Data Requirements

- Selected “Bid”

High Level Steps

M/SP

1. M/SP informs success DSO “bids” of their selections and communicates dispatch requirements (MW/MVar, duration, ramp rate, price, etc...) for each of the zones
2. DER(A) acknowledges receipt and commitment

Field Operation - Selection

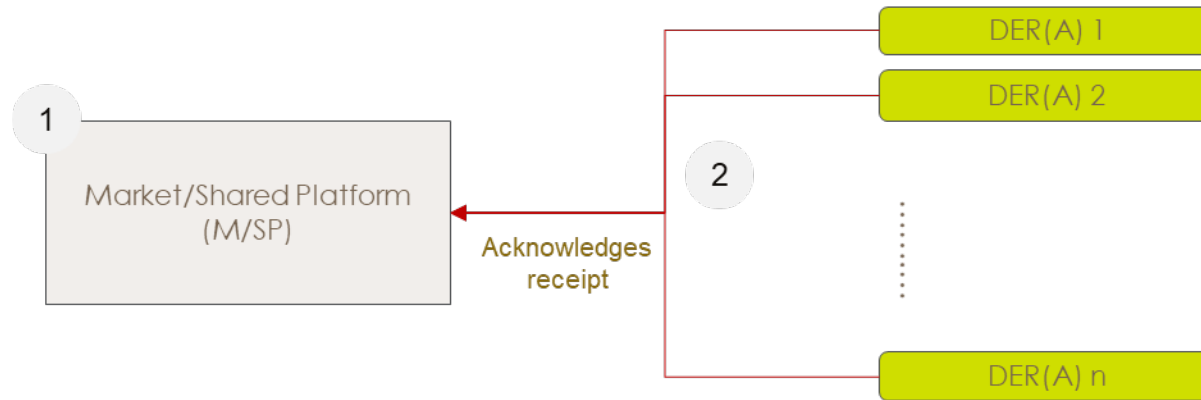

Field Operation – DER Outage

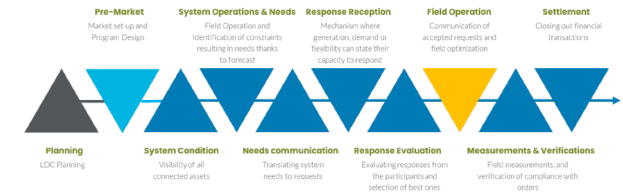

Objective

- DER(A) indicates an outage or change in contract commitment

Impacted Stakeholder

- IESO
- DSO
- DER(A)

High Level Steps

M/SP

1. **DER(A)** register any changes in contract commitments

Forecaster

2. *Forecaster* update forecast based on DER(A) changes to contract commitments, historical telemetry, system telemetry, meter data)

WDSC

3. *WDSC* collates all necessary data (Contracts, load & generation forecast, network models, system telemetry)

Power System Analysis

4. *PSA* runs a time-series (for the appropriate market time frames) security constraint power flow for each of the zones to determine the impact of contracted committed contracts on the

Impacted Systems

- Whole Distribution System Coordinator (WDSC)
- Market/Shared Platform (M/SP)
- Power System Analysis
- Forecaster

Data Requirements

- DER(A) Contract commitments, forecasts, system telemetry, network models

system (network conditions continuously change)

5. *PSA* runs a time-series (for the appropriate market time frames) security constraint power flow for each of the zones to determine optimal network operations to accommodate maximum DER participation, if step 4 identifies system constraints

WDSC

6. *WDSC* communicates potential limits on DERs

M/SP

7. *M/SP* informs **DER(A)** and **IESO** of any limitations/changes placed on **DER(A)** with support information

Field Operation – DER Outage

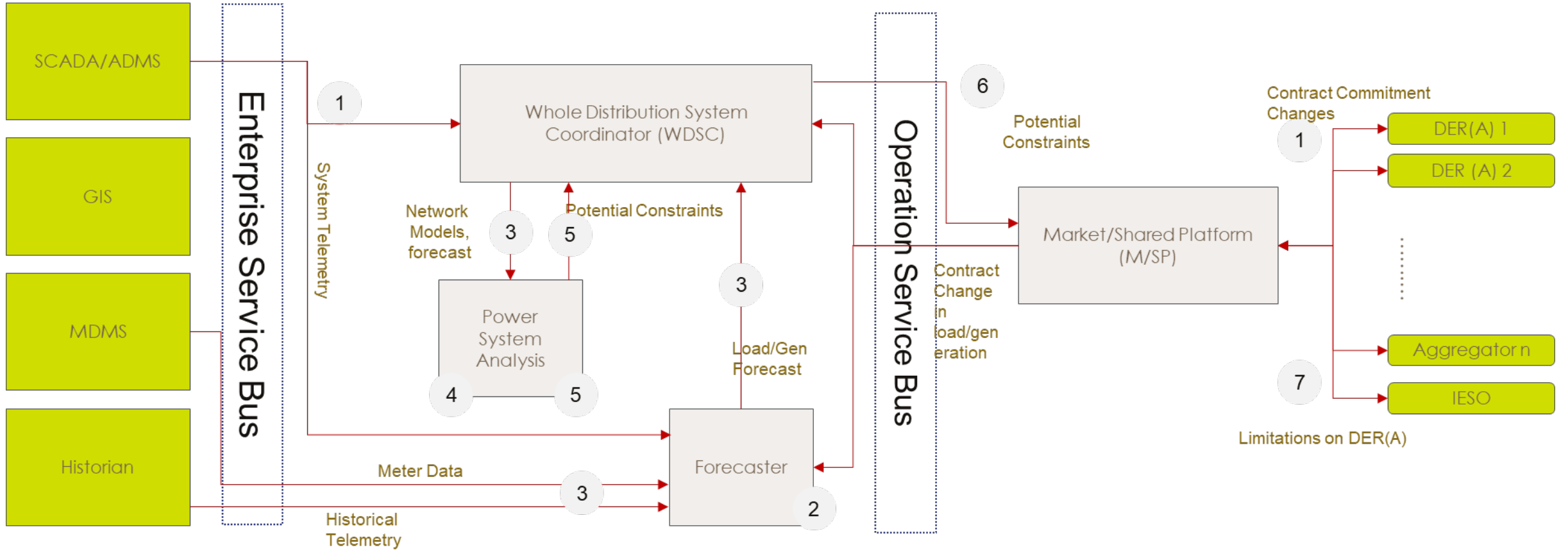
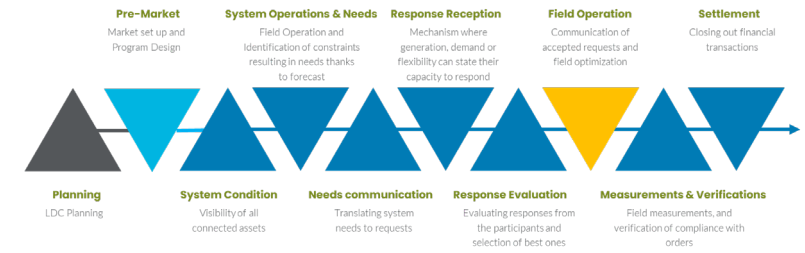

Field Operation - Dispatch

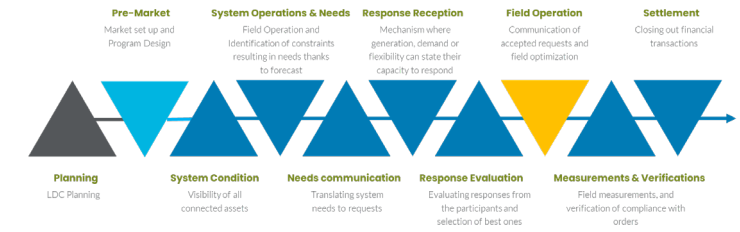

Objective

- DSO dispatching DER(A)

Impacted Systems

- Market/Shared Platform (M/SP)

Impacted Stakeholder

- DSO
- IESO
- DER(A)

Data Requirements

- Selected "Bid"

High Level Steps

M/SP

1. IESO provides information on all the selected bids (asset owner, dispatch schedule, etc...)
2. M/SP sends the dispatch schedules to WDSC

WDSC

3. WDSC collates all necessary data (Contracts, load & generation forecast, network models, system telemetry)

Power System Analysis

4. PSA runs a time-series (for the appropriate market time frames) security constraint power flow for each of the zones to determine the impact of contracted committed contracts on the system (network conditions continuously change)

5. PSA runs a time-series (for the appropriate market time frames) security constraint power flow for each of the zones to determine optimal network operations to accommodate maximum DER participation, if step 4 identifies system constraints

WDSC

6. WDSC sends the dispatch signal to DERs

M/SP

7. M/SP informs DER(A) and IESO of any limitations placed on DER(A) with support information
8. M/SP facilitates the dispatch signal
9. DER(A) acknowledges receipt and commitment

Field Operation - Dispatch

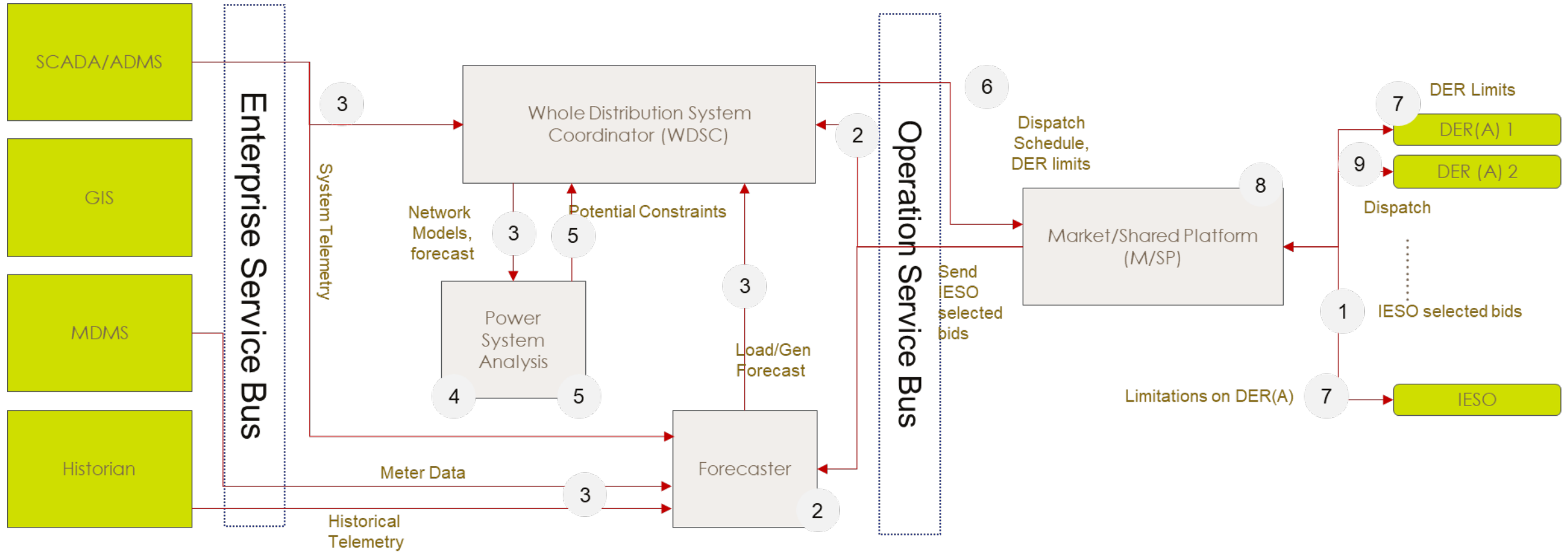
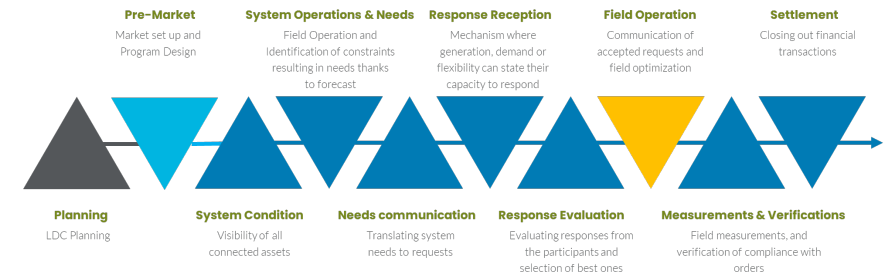

Measurement and Verification



Objective

- Measuring the dispatch of the market participants to verify the successful execution of dispatch

Impacted Stakeholder

- IESO
- DER(A)
- DSO

High Level Steps

M/SP

1. **DER(A)** submits Energy Resource measurements to M/SP after the delivery day of transactions (optional)

MDMS

2. **MDMS** collects metered measurements from each of the participants and passes the information to the **WDSC**

Historian

3. **Historian** collects field telemetry and passes the information to the **WDSC**

WDSC

4. **WDSC** collates all the measurements data, telemetry data and network models (with the time appropriate topography information) and passes to **PSA**

Impacted Systems

- Market/Shared Platform (M/SP)
- Power System Analysis
- Whole Distribution System Coordinator (WDSC)
- MDMS

Data Requirements

- Field Telemetry, metered data, network models, measurements from participants

Power System Analysis

5. **PSA** runs a security constraint power flow analysis for measured data from M/SP and MDMS and telemetry data

WDSC

6. **WDSC** compares between results from power flow analysis of measurements (MDMS and M/SP) and field telemetry to determine, evaluate and address discrepancies
7. **WDSC** passes results of comparison results to **M/SP**

M/SP

8. Provide information to **DER(A)** for review and dispute
9. **DER(A)** sends information as part of the dispute (restart at step 1),
10. If there is no dispute from **DER(A)** and Provide information to **IESO** and **DER(A)**, **IESO** can dispute (restart at step 1)

Measurement and Verification

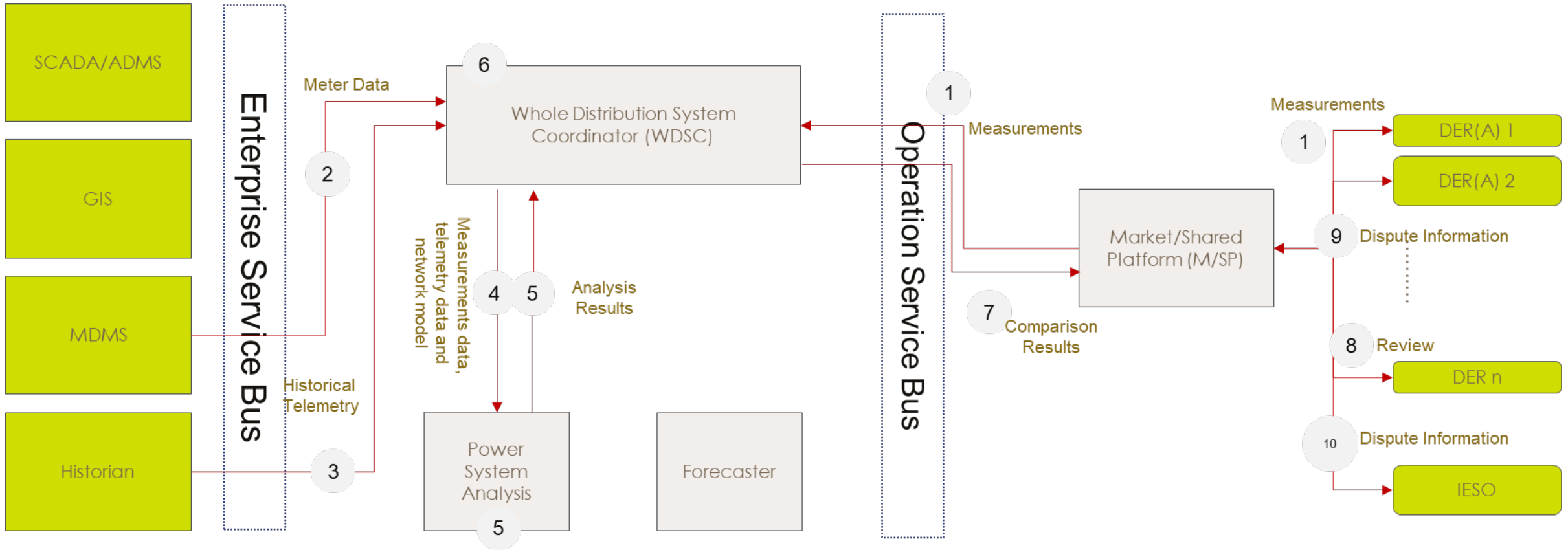
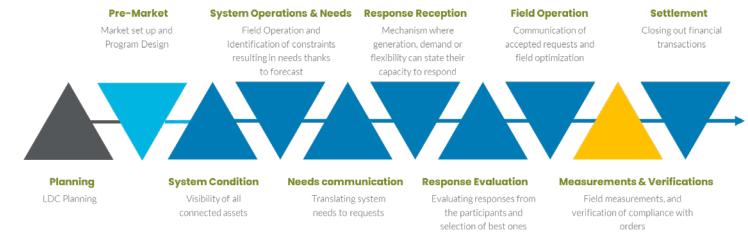

Settlement

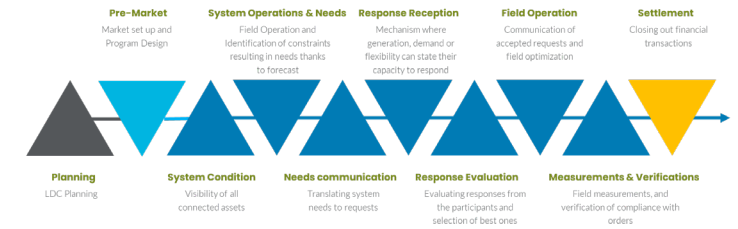

Objective

- Calculates payment between the market operator and different market participants that provided services

Impacted Systems

- Market/Shared Platform (M/SP)

Impacted Stakeholder

- DER(A)
- DSO
- IESO

Data Requirements

- Measurement and Verification

High Level Steps

M/SP

1. M/SP manages the appropriate payments. Payments will depend on market clearing mechanism, transaction price, and other selected payment rules (ex. Non-performance may involve penalties)
2. DER(A) reviews the measurement and verification determination (could dispute it – dispute mechanisms are detailed designed item)

Settlement

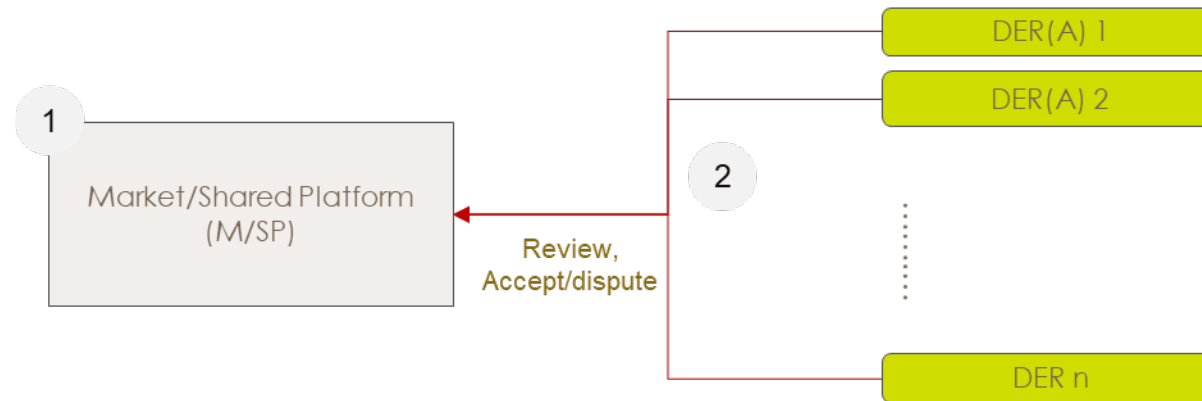
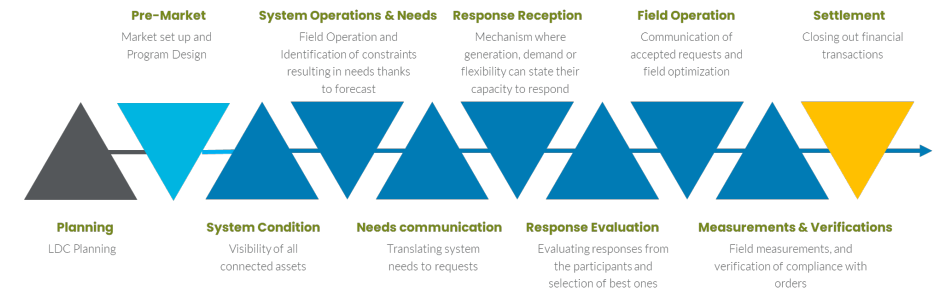

Thank You

