Draft Synchrophasor Data Requirements

Updated Version
February, 2022

Table of Contents

1. Introduction	2
1.1 Purpose	2
1.2 Scope	2
1.3 Real-Time Monitoring Devices	2
1.4 Overview of Synchrophasor Data Requirements	3
1.5 Typical Infrastructure Required for Providing Synchrophasor Data Phasor Measurement Unit (PMU) 3	
1.6 Phasor Data Concentrator (PDC)	4
1.7 Phasor Estimator	5
2. Monitoring Requirements: Generators	7
2.1 Phasor Data Requirements for Generators	7
2.2 Applicable Generator Connection Configurations	12
2.3 Low Capacity Factor	13
3. Monitoring Requirements: Transmitters	14
3.1 Phasor Data Requirements for Transmitters	14

1. Introduction

1.1 Purpose

The primary objective of the Synchrophasor Data Requirements manual is to provide Market Participants with technical specifications and guidelines for supplying synchrophasor data with the required attributes to the IESO for utilizations in planning and operation of the IESO-controlled grid.

1.2 Scope

The scope of this manual comprises technical requirements of the synchrophasor data to be provided to the IESO by certain transmitters and generators connected to the IESO-controlled grid.

The synchrophasor data are generated mainly by stand-alone devices called Phasor Measurement Units (PMU). The synchrophasor data can also be generated by other dual-purpose devices such as (1) modern Dynamic Disturbance Recorders¹ (DDRs) or (2) Intelligent Electronic Devices (IEDs) ~~of relays which is~~ used for protection. The technical requirements and functionalities of those three devices are unique and vastly different to each other. The scope of this manual does not include technical requirements of those devices, but is instead focused on clarifying the technical requirements of the synchrophasor data any of those devices must generate in order to meet the IESO's requirements.

The synchrophasor data from the generating device are transmitted to the IESO via a processor called ~~athe~~ Phasor Data Concentrator (PDC). The technical requirements of the PDC are also not in the scope of this manual. The technical requirements of the PDC are immaterial to the IESO as long as the synchrophasor data adheres to the technical requirements specified in this manual.

The technical requirements presented here are to aid generation and transmission facilities already in-service as well as those facilities approved to be connected to the IESO-controlled grid. In the latter case, the requirements specified in this manual can be used as a guide to make initial plans on designing synchrophasor measurement systems which should then be shared with and reviewed by the IESO during the market registration and connection assessment processes. The applicable market participants ~~are expected to include synchrophasor data under their North American Electric Reliability Corporation (NERC) will need to comply with NERC~~ Critical Infrastructure Protection (CIP) program ~~requirements~~. The IESO will initially use the synchrophasor data for non-CIP related activities, as such meeting applicable CIP requirements may not be triggered until later in the IESO's PMU Integration Program in Ontario. Before the IESO's PMU Integration Program in Ontario advances to the point to where applicable CIP requirements will be triggered, the IESO will engage with stakeholders to provide reasonable timeline for the implementation of any specific CIP requirements.

1.3 Real-Time Monitoring Devices

¹ Newer versions of DDRs with PMU capabilities

There are several tools such as SCADA, Phasor Measurement Units, Power System Data Recorders (PSDR), Digital Fault Recorders (DFR) and Dynamic Disturbance Recorders (DDRs) conventionally used for the purpose of real-time power system monitoring for various degrees.

The devices that generate synchrophasor data offer the following benefits compared to previous monitoring standards:

- (1) a time-stamp as per Coordinated Universal Time (UTC).
- (2) phase angles.
- (3) higher data reporting rate (i.e. 30 - 120 samples per second).
- (4) continuous real-time measurements.

The data from SCADA, PSDR, DFR and DDR have limitations compared to synchrophasor data, including:

- SCADA provides real-time measurements continuously but at a much slower reporting rate (2 - 4 samples per second), does not measure phase angle and data contains no universal time stamp.
- Data from PSDR, traditional DFR, and traditional DDR ~~have similar or higher reporting rate compared to synchrophasor data,~~ provide phase angles, ~~data~~ contains universal time stamps, ~~and have similar or higher reporting rate compared to synchrophasor data,~~ however these devices are only for recording (i.e. not real-time).
- Data recording in DFR is non-continuous and triggered by certain variables such as voltage or frequency exceeding certain thresholds or abnormal levels.

1.4 Overview of Synchrophasor Data Requirements

Synchrophasor data requirements are documented in Market Rules Chapter 4, Appendix 4.15 for generators connected to the IESO-controlled grid and Market Rules Chapter 4, Appendix 4.16 for transmitters. This document elaborates on those requirements.

1.5 Typical Infrastructure Required for Providing Synchrophasor Data ~~Phasor Measurement Unit (PMU)~~

The PMU is a device that generates synchrophasor data by estimating the magnitude and phase angle of voltage and current waveforms and stamping them with time of measurement from a time source provided by the Global Positioning System (GPS). The resulting data are known as synchrophasor since each data, regardless of the type, originating location, or equipment, is stamped with the time of measurement as per Coordinated Universal Time (UTC) which is typically the Greenwich Mean Time (GMT), hence subsequently the measurements can be precisely synchronized.

~~The~~ Typical infrastructure required for providing synchrophasor data ~~using PMU~~ includes ~~an Instrumentation Channel,~~ the PMUs, Phasor Data Concentrators (PDCs), GPS antenna, local clock, ~~and a communication network and data storage.~~ A typical Instrumentation Channel consists of Instrument Transformers (ITs) and the physical components connecting the ITs to the PMU (such as control cables). An overview of their connectivity is shown in **Figure 1**.

Figure 1 | Typical infrastructure required for providing synchrophasor data Components of PMU

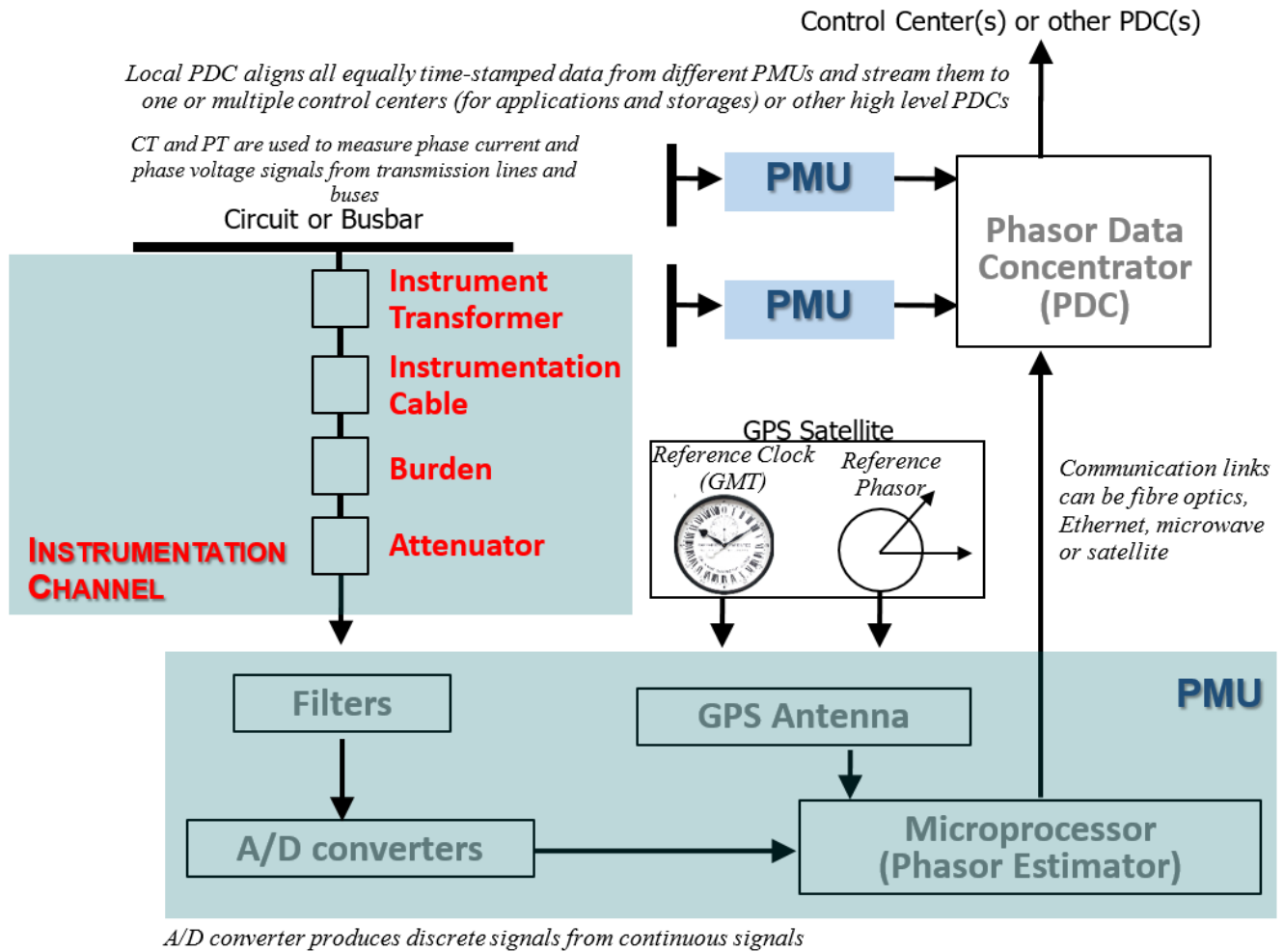

1.6 Phasor Data Concentrator (PDC)

The PDC works as a node in a communication network where synchrophasor data are processed and fed out as a single stream to higher level PDCs or control center applications. There are multiple levels of PDCs (i.e., local, mid-level and high-level) performing different roles as shown in Figure 2. The local PDC is owned by the generator or the transmitter and located at close vicinity of the generator or transmitter facility. The local PDC aggregates and aligns all phasor data reaching it from different synchrophasor data generating devices based on the UTC time-stamp regardless of their arrival order or time and then allows those synchronized phasors to proceed to mid-level PDCs. This compacting of synchrophasor data before they are sent on to the mid-level PDC minimizes the communication bandwidth between local and mid-level PDC and also creates a synchronized measurement set for the local system.

Mid-level PDCs, which are typically owned by same entity as the local PDC, collect synchrophasor data from multiple local PDCs, conduct data quality checks, and re-align all inputs based on UTC time-stamp. They then feed to various synchrophasor data based computer applications such as Network Monitoring Systems and State Estimators (SE) or are stored in local control centers. From multiple mid-level PDCs, often synchrophasor data proceeds to a high level PDC which is usually

regionally based and performs similar functions as mid-level PDCs at a large scale such as Wide-Area Monitoring System (WAMS).

The number and the hierarchy of different PDCs in a synchrophasor measurement system vary with the size of the power grid, monitoring extent and visibility requirements, ownership of synchrophasor data, capacity of each PDC, communication network, etc. The PDCs may be considered ~~as~~ an administrative function rather than an electrical device or hardware/software package. A structured hierarchy of PDCs can be formed to serve a large power grid constituting multiple substations, utilities, control areas, reliability coordinators and interconnections; ~~and~~ Synchrophasor data is streaming through them via a large network of communication links as data quality checks and applications take place at different points. Market Participants should refer to the latest IEEE standards applicable to PDC requirements.

Figure 2 | PMU and Phasor Data Concentrators

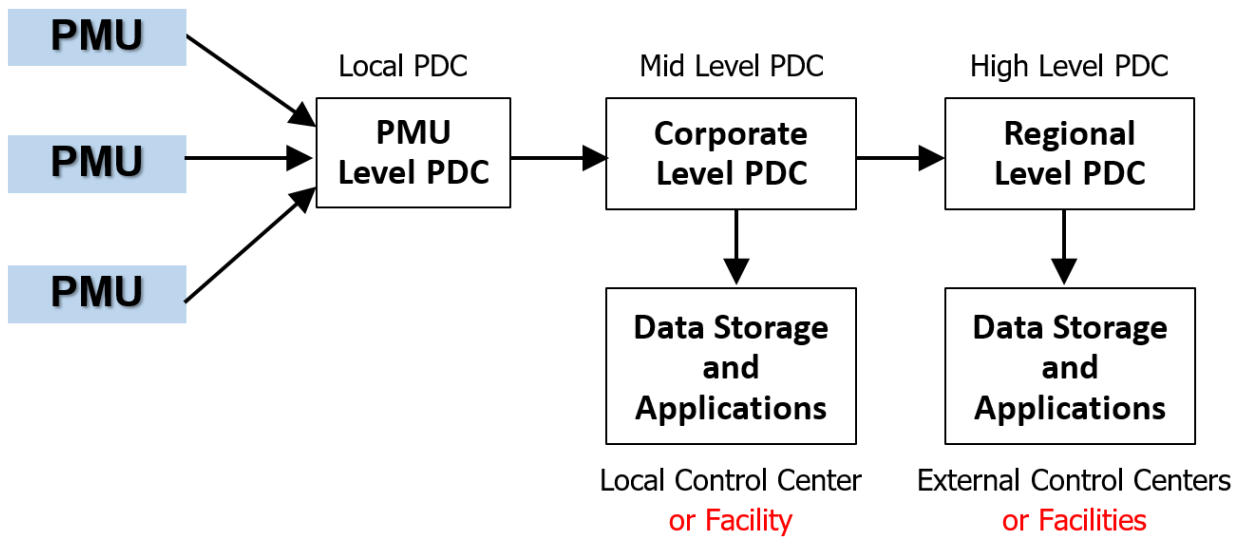

1.7 Phasor Estimator

AC waveforms typically oscillate at or close to 60 Hz frequency (i.e. 60 cycles take place in 1 second). It could be perfectly sinusoidal during steady-state or distorted during dynamics as the example shown in **Figure 3** which depicts as 0.1 Hz oscillations in the power system.

Figure 3 | AC waveform during dynamics

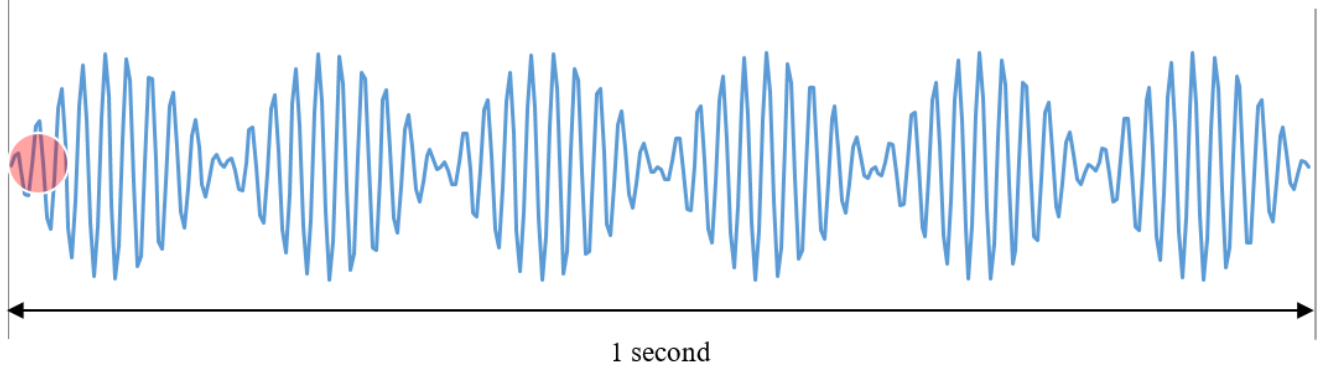

The Analog to Digital (A/D) converter built into the PMU does the followings on the continuous phase voltage and phase current waveforms where the values are measured by potential transformers (PTs) and current transformers (CTs).

- (1) Select preceding $60/N$ cycle segments in last $1/30$ sec of waveforms from A, B, C phase voltages and A, B, C phase currents ($N =$ reporting rate).
- (2) Discretize each selected continuous waveform segment to a large number of separate data points.

The phasor estimator is a mini-computer built into the synchrophasor data generating device that performs following calculations on the discretized waveform segments in order to derive the phasors.

- (3) Use Discrete Fourier Transformation (DFT) algorithm in the mini-computer to calculate A_1 and B_1 correspond to the term $A_1 \cos \omega t + B_1 \sin \omega t$ of each current phase and voltage phase.
- (4) Convert each $A_1 \cos \omega t + B_1 \sin \omega t$ to the form of $C \sin (\omega t + \alpha)$.
- (5) Compare each $C \sin (\omega t + \alpha)$ to the common reference phasor $\sin (\omega t + \beta)$ from the GPS.
- (6) Assign rms magnitude $C/\sqrt{2}$ and angle $(\alpha - \beta)$ to the corresponding waveform segment of each phase voltage and phase current.
- (7) Assign UTC corresponds to the mid-point of the waveform segment to each magnitude and angle calculated in (6).
- (8) Repeat (1) – (7) for next $60/N$ cycle segments of waveforms.

In addition to above, following optional calculations are available in the mini-computer.

- Compute positive, negative, zero sequence magnitudes and angles of phase voltages and currents.
- Compute 3-phase active power and reactive power.
- Compute frequency.
- Compute rate of change of frequency.

2. Monitoring Requirements: Generators

2.1 Phasor Data Requirements for Generators

Generators shall install and maintain at its expense, synchrophasor data generating devices and required infrastructure including instrument transformers, communication channels and PDCs, and provide synchrophasor data as per below specifications to the IESO on continuous basis.

Specifications noted as “required” must be satisfied, specifications noted as “preferred” are not currently required but add additional operational value and should be satisfied wherever practical and may become “required” in future if needed for any reliability purposes.

Table 1 | Requirements for Generators

Attribute	Status	Requirement
Measurement Point	Required	<p>(1) If a single generating unit is rated equal to or greater than 100 MVA (name-plate rating) and directly connected to the IESO-controlled grid, provide synchrophasor data measured at generator terminal (i.e. low side of the generator output transformer). See configuration 1 of Figure 4.</p> <p>(2) If a generator facility has multiple generator units and aggregate equal to or greater than 100 MVA (aggregate name-plate rating) and connected to the IESO-controlled grid, provide aggregated synchrophasor data measured at the generator facility side of each point of connection to the IESO-controlled grid. See configurations 2, 3, 4 of Figure 4. Alternatively, other measuring locations of synchrophasor data inside the facility can be provided if they allow for calculating the aggregated synchrophasor data at the generator facility side of each point of connection. See configurations 2, 3, 4 of Figure 4.</p> <p>Eligible generation facilities in (1) and (2) are not required to provide the synchrophasor data if they meet the following criterion:</p> <ul style="list-style-type: none"> The generation facility is not directly connected to a Bulk Power System (BPS) Station or and has no connection point voltage greater than 200 kV.

Attribute	Status	Requirement
		<p>Eligible generation facilities in (1) and (2) may not be required to provide the synchrophasor data if they meet one of the following criteria:</p> <ol style="list-style-type: none"> a. The generation facility will is expected to be deregistered within a period of 5 years from date of implementation of market rules. b. The annual gross capacity factor of the generation facility is significantly low as stated in the process covered in section 2.3. <p>The applicability of criteria (a) and (b) above are subject to the IESO's periodic review and assessment of the decommissioning plan and evaluation of capacity factors s respectively, per mutual-agreement on a case-by-case basis.</p>
Measurement Point	Required	<p>For generation units, regardless of rated size, whose output power flow is a part of an Interconnection Reliability Operating Limit (IROL) definition, provide positive sequence voltage phasor, positive sequence current phasor and frequency at the terminals defining the IROL. This requirement will take precedence even if a facility meets any of the applicability criteria (a) and (b) listed above.</p>
Measurement Point	Preferred	<p>Provide additional synchrophasor data from a generator facility for specific reliability needs (e.g. generation facility with history of oscillatory events or to achieve sufficient observability over the IESO controlled grid).</p>
Measured Quantities and Units	Required	<p>Provide frequency (Hz), positive sequence voltage magnitude (Volts or kV), positive sequence voltage phasor angle (degrees), positive sequence current phasor magnitude (Amperes or kA), and positive sequence current phasor angle (degrees). Actual measurement of all three phases is required for calculation of above phasors. It is not mandatory to have dedicated measuring devices to provide required measured quantities.</p>
Measured Quantities	Preferred	<p>Provide rate of change of frequency, individual RYB phase current and RYB phase voltage phasors.</p>

Attribute	Status	Requirement
		<p>If providing aggregated positive sequence phasors requires installing instrument transformers to individual generators, provide phasor data from individual generators.</p> <p>Note: Individual phase voltage and current phasor data are valuable for analyzing phase imbalance problems.</p>
Coordinates	Required	Provide phasor data in polar coordinates where angles must be in degrees in the range 0 to 360 and magnitudes must be in SI units.
System Frequency	Required	Provide phasor data continuously at frequency between 57 Hz and 62 Hz.
Reporting Rate	Required	Provide synchrophasor data at least once in every one thirtieth of a second (i.e. 30 samples per second).
Reporting Rate	Preferred	<p>Provide phasors data at least once in every one sixtieth of a second (i.e. 60 samples per second).</p> <p>Note: Typical mid-term dynamic analysis tools provide 240 data point sets per second. Dynamic model validation using synchrophasor data can be improved if reporting rate is increased to 60 samples per second.</p>
Time-Tag Format and Accuracy	Required	<p>All synchrophasor data shall be reported in Coordinated Universal Time (UTC time) with zero offset. For each phasor measurement, data shall include a time tag traceable to UTC clock that includes the time and time quality at the time of measurement. The time tag shall accurately resolve time of measurement to at least 1μs within a specified 100-year period.</p> <p>Provide phasor data with time stamp equal or less than 1 microsecond accuracy from Coordinated Universal Time (UTC) clock.</p> <p>Provide phasors data in UTC with zero offset.</p> <p>Notes:</p> <p>(1) Time offset is an amount of time subtracted from or added to UTC to get the current civil time, whether it is standard time or daylight saving time (DST).</p>

Attribute	Status	Requirement
		(2) A time error of 1 microsecond corresponds to a phasor error of 0.022 degrees for a 60 Hz system.
Data Format and Accuracy Standard	Required	<p>Provide phasor data in the IEEE format. The Total Vector Error (TVE) shall be less than 1%.</p> <p>Data provided to the IESO shall comply with the IEEE Std 60255-118-1-2018. For Market Participants connected to the IESO-controlled grid with synchrophasor data measurement infrastructure meeting IEEE Std C37.118 (2005, 2011, or 2014) and existing before the implementation date of the synchrophasor data Market Rules requirements, the IESO will accept utilization of such measurement infrastructure. The IESO will work with these Market Participants to assess the need for any future upgrades in their synchrophasor data measurement infrastructure, and if necessary, develop a staged implementation plan.</p>
Network Protocol	Required	Provide phasor data via a network that comply with TCP/IP or UDP/IP protocol.
Instrumentation TransformersChannel	Required	<p>Provide instrument transformers and its corresponding instrumentation channel components with accuracy equal or better than those used for SCADA measurements high enough to be appropriately utilized in IESO real-time applications⁽²⁾.</p>
Latency	Required	<p>Provide total latency for phasor data low enough to be appropriately utilized in IESO real-time applications.</p> <p>Note: Total latency depends on reporting rate, PMU classification (M or P), PMU computation time, PDC time and communication time. Higher latency makes phasor data ineffective in real-time applications and low latency makes increased loss of phasor data at the PDC.</p>

² This requirement intends to provide flexibility to market participants to utilize their current Instrumentation Channel infrastructure with minimum accuracy equal or better than those used for SCADA measurements. Should Instrumentation Channel specifications be prescribed in the future, the IESO will stakeholder them with Market Participants in advance and support reasonable staged implementation plans to deploy any resulting required equipment upgrades to comply with such specifications.

Attribute	Status	Requirement
Latency	Preferred	Provide total latency for phasor data from PMU to the IESO control center or IESO owned PDC no more than 100 ms if that data is to be used in a Linear State Estimator whose output is to be used in on-line Transient Stability program.
Bandwidth	Required	<p>Provide communication channels with bandwidth adequate to transmit the volume of phasor data at selected reporting rate.</p> <p>Note: The required bandwidth varies with the number of phasor data and reporting rate. Thus, the size of bandwidth required depends on the reporting rate, the facility MVA size and configuration and the communication segment for which bandwidth is applicable (i.e. from PMU to local PDC, local PDC to mid-level, mid-level to high level).</p>
Bandwidth	Preferred	Provide dedicated communication channels to avoid any data transmission interruption and excessive latency.

2.2 Applicable Generator Connection Configurations

Figure 4 | Examples for synchrophasor data measurement locations for different generator connection configurations

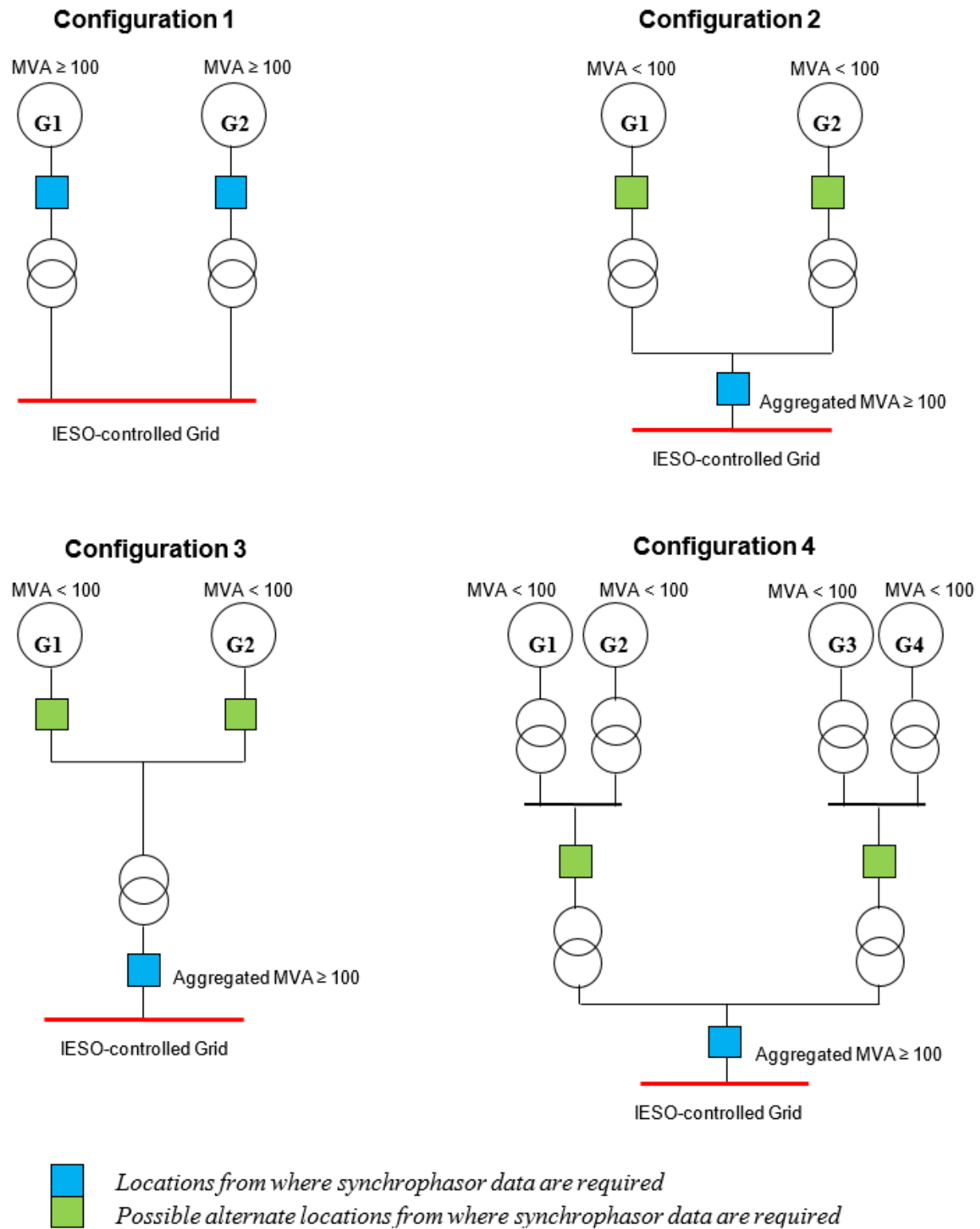

2.3 Low Capacity Factor

This section explains the process for identifying generation facilities that are not required to provide synchrophasor data because of their low Capacity Factor (CF). The average CF is calculated using historical data for the last 3 years or since the in-service date, whichever is less. Only facilities with $CF < 10\%$ are excluded from the obligation to meet synchrophasor requirements. The list of excluded facilities will be developed by the IESO and shared with the facility owners. The IESO will continue with calculating annually the moving average for CF of excluded facilities only. Upon performing the annual assessment, if $CF \geq 10\%$, the IESO will notify the facility owner that:

- The exclusion from synchrophasor requirements is no longer valid
- The facility will no longer be included for future annual CF assessments
- Synchrophasor data must be provided to the IESO within 3 years from the notification date. Market Participants having multiple facilities, may provide synchrophasor data via mutually agreed staged implementation plan, if required.

Future generation projects will be assessed to determine if they qualify for exclusion from the synchrophasor requirements.

Regardless of generators CF, the IESO may require generation facilities to provide synchrophasor data for reliability and system awareness purposes. Such need will be informed by considerations such as proximity to other synchrophasor measurement units, criticality of the facility from system stability perspective, etc.

3. Monitoring Requirements: Transmitters

3.1 Phasor Data Requirements for Transmitters

Transmitters shall install and maintain at its expense synchrophasor data generating devices and required infrastructure including instrument transformers, communication channels and PDCs, and provide synchrophasor data as per below specifications to the IESO on continuous basis.

Specifications noted as “required” must be satisfied, specifications noted as “preferred” are not currently required but add additional operational value and should be satisfied wherever practical and may become “required” in future if needed for any reliability purposes.

Table 2 | Requirements for Transmitters

Attribute	Status	Requirement
Measurement Points and quantities	Required	<ul style="list-style-type: none"> • Two separate 500 kV buses in 500 kV stations, two separate BPS-classified buses in BPS stations, two separate buses in stations that are required to restore the grid from black-start units. Provide positive sequence voltage phasor magnitude, positive sequence voltage phasor angle, and frequency. • Terminals of circuits defining Interconnection Reliability Operating Limits (IROL) and Interties. Provide positive sequence current phasor magnitude, positive sequence current phasor angle, positive sequence voltage phasor magnitude, positive sequence voltage phasor angle, and frequency. • Terminal bus of Static Var Compensators (SVC), synchronous condensers and static synchronous compensators (STATCOM). Provide positive sequence current phasor magnitude, positive sequence current phasor angle, positive sequence voltage phasor magnitude, positive sequence voltage phasor angle, and frequency.

Attribute	Status	Requirement
Measurement Points and quantities	Preferred	<p>Provide positive sequence current phasor magnitude and positive sequence current phasor angle from one circuit terminal for circuits required to restore the grid from black-start units.</p> <p>Provide rate of change of frequency, individual RYB phase current and RYB phase voltage phasors.</p> <p>Positive sequence current phasors and positive sequence voltage phasors from high-side and low-side of auto-transformers.</p> <p>Notes:</p> <p>(1) Individual phase voltage and phase current phasor data are useful in analyzing phase imbalance problems.</p> <p>(2) With both low-side and high-side phasor data from auto-transformers, the impact of Geo-Magnetically Induced (GIC) currents can be monitored.</p>
Units of Measured Quantities and Units	Required	<p>Provide frequency (Hz), positive sequence voltage magnitude (Volts or kV), positive sequence voltage phasor angle (degrees), positive sequence current phasor magnitude (Amperes or kA), and positive sequence current phasor angle (degrees).</p> <p>Actual measurement of all three phases is required for calculation of above phasors. It is not mandatory to have dedicated measuring devices to provide required measured quantities.</p>
Coordinates	Required	<p>Provide phasor data in polar coordinates where angles must be in degrees in the range 0 to 360 and magnitudes must be in SI units.</p>
System Frequency	Required	<p>Provide phasor data continuously at frequency between 57 Hz and 62 Hz.</p>
Reporting Rate	Required	<p>Provide synchrophasor data at least once in every one thirtieth of a second (i.e. 30 samples per second).</p>

Attribute	Status	Requirement
Reporting Rate	Preferred	<p>Provide phasors data at least once in every one sixtieth of a second (i.e. 60 samples per second).</p> <p>Note: Typical mid-term dynamic analysis tools provide 240 data point sets per second. Dynamic model validation using synchrophasor data can be improved if reporting rate is increased to 60 samples per second.</p>
Time-Tag Format and Accuracy	Required	<p>All synchrophasor data shall be reported in Coordinated Universal Time (UTC time) with zero offset. For each phasor measurement, data shall include a time tag traceable to UTC clock that includes the time and time quality at the time of measurement. The time tag shall accurately resolve time of measurement to at least 1μs within a specified 100-year period.</p> <p>Provide phasor data with time stamp equal or less than 1 microsecond accuracy from Coordinated Universal Time (UTC) clock.</p> <p>Provide phasors data in UTC with zero offset.</p> <p>Notes:</p> <p>(1) Time offset is an amount of time subtracted from or added to UTC to get the current civil time, whether it is standard time or daylight saving time (DST).</p> <p>(2) A time error of 1 microsecond corresponds to a phasor error of 0.022 degrees for a 60 Hz system.</p>
Data Format and Accuracy Standard	Required	<p>Provide phasor data in the IEEE format. The Total Vector Error (TVE) shall be less than 1%.</p> <p>Data provided to the IESO shall comply with the IEEE Std 60255-118-1-2018. For Market Participants connected to the IESO-controlled grid with synchrophasor data measurement infrastructure meeting IEEE Std C37.118 (2005, 2011, or 2014) and existing before the implementation date of the synchrophasor data Market Rules requirements, the IESO will accept utilization of such measurement infrastructure. The IESO will work with these Market Participants to assess the need for any future upgrades in their synchrophasor data measurement infrastructure, and if necessary, develop a staged implementation plan.</p>

Attribute	Status	Requirement
Network Protocol	Required	Provide phasor data via a network that comply with TCP/IP or UDP/IP protocol.
Instrumentation TransformersChannel	Required	Provide instrument transformers and its corresponding instrumentation channel components with accuracy equal or better than those used for SCADA measurements high enough to be appropriately utilized in IESO real-time applications ⁽³⁾ .
Latency	Required	Provide total latency for phasor data low enough to be appropriately utilized in IESO real-time applications. Note: Total latency depends on reporting rate, PMU classification (M or P), PMU computation time, PDC time and communication time. Higher latency makes phasor data ineffective in real-time applications and low latency makes increased loss of phasor data at the PDC.
Latency	Preferred	Provide total latency for phasor data from PMU to the IESO control center or IESO owned PDC no more than 100 ms if that data is to be used in a Linear State Estimator whose output is to be used in on-line Transient Stability program.
Bandwidth	Required	Provide communication channels with bandwidth adequate to transmit the volume of phasor data at selected reporting rate. Note: The required bandwidth varies with the number of phasor data and the reporting rate. Thus, the size of bandwidth required depends on reporting rate, the facility MVA size and configuration and the communication segment for which bandwidth is applicable (i.e. from PMU to local PDC, local to mid-level, mid-level to high level).
Bandwidth	Preferred	Provide dedicated communication channels to avoid any data transmission interruption and excessive latency.

³ This requirement intends to provide flexibility to market participants to utilize their current Instrumentation Channel infrastructure with minimum accuracy equal or better than those used for SCADA measurements. Should Instrumentation Channel specifications be prescribed in the future, the IESO will stakeholder them with Market Participants in advance and support reasonable staged implementation plans to deploy any resulting required equipment upgrades to comply with such specifications.

**Independent Electricity
System Operator**

1600-120 Adelaide Street West
Toronto, Ontario M5H 1T1

Phone: 905.403.6900

Toll-free: 1.888.448.7777

E-mail: customer.relations@ieso.ca

ieso.ca

 [@IESO_Tweets](https://twitter.com/IESO_Tweets)

 linkedin.com/company/IESO