

**MAY 20, 2026**

# ERP Storage and Co-located Hybrid Integration Project

## Phase 1 Market Design

Independent Electricity System Operator (IESO)

# Disclaimer

This presentation and the information contained herein is provided for informational purposes only.

The IESO has prepared this presentation based on information currently available to the IESO and reasonable assumptions associated therewith, including relating to electricity supply and demand. The information, statements and conclusions contained in this presentation are subject to risks, uncertainties and other factors that could cause actual results or circumstances to differ materially from the information, statements and assumptions contained herein.

The IESO provides no guarantee, representation, or warranty, express or implied, with respect to any statement or information contained herein and disclaims any liability in connection therewith. In the event there is any conflict or inconsistency between this document and the IESO market rules, any IESO contract, any legislation or regulation, or any request for proposals or other procurement document, the terms in the market rules, or the subject contract, legislation, regulation, or procurement document, as applicable, govern.

# Territory Acknowledgement

The IESO acknowledges the land we are delivering today's webinar from is the traditional territory of many nations including the Mississaugas of the Credit, the Anishnawbe, the Chippewa, the Haudenosaunee and the Wendat peoples and is now home to many diverse First Nations, Inuit and Métis peoples. We also acknowledge that Toronto is covered by Treaty 13 with the Mississaugas of the Credit First Nation.

As we have attendees from across Ontario, the IESO would also like to acknowledge all of the traditional territories across the province, which includes those of the Algonquin, Anishnawbe, Cree, Oji-Cree, Huron-Wendat, Haudenosaunee and in addition to the Métis and Inuit peoples.

# Engagement Principles

This engagement is conducted in accordance with the IESO's [External Engagement Framework](#), which includes the following principles:

- **Purposeful** – Initiate meaningful conversations that move the sector forward
- **Inclusive** – Invite many voices and diverse perspectives to the table
- **Timely** – Seek input and insight when it can have the most impact
- **Accessible** – Ensure we meet people where they are on their energy journey
- **Traceable** – Allow everyone to follow the path that is being taken
- **Transparent** – Show how engagement helped shape the final outcome

# Shared Commitment to Respectful Participation

## To support a focused and constructive discussion:

- We will take questions one at a time; please use the raise-hand feature to enter the speaking queue
- We encourage concise and focused comments to allow time for multiple perspectives
- Participants are encouraged to raise relevant points during the discussion and provide more detailed feedback through the written submission process
- We ask that all participants maintain a respectful and professional tone throughout the session
- Facilitators will guide the discussion and manage participation to stay aligned with today's focus and agenda
- Where necessary, we may disable a participant's microphone to manage participation

# Information Session Recording and Webpage

- Today's session will be **recorded** and available for viewing online
- **Meeting materials** are posted on the Public Information Session webpage created for this topic
- Please visit the Public Information Session's webpage [here](#)

# Agenda

- Benefits of Design
- Design updates:
  - Optimization
  - Connection and Registration
  - Dispatch Data and Other Inputs
  - Market Power Mitigation
- Day-in-the-Life Scenarios
  - Scenarios for co-optimization of Energy and Operating Reserves (OR) in Day-Ahead Markets (DAM)
  - General scenarios for co-optimization of energy and OR in Real Time (RT)
- Next Steps and Feedback

# Enabling Resources Program Scope

The Enabling Resources Program is a set of projects that will further enable key emerging resources, specifically electricity storage ("storage"), hybrid generation-storage pairings ("hybrids") and aggregations of Distributed Energy Resources ("DERs") into the IESO-administered markets, tools, and processes to provide required system services and contribute to the safe and reliable operation of the bulk power system in Ontario.

# Enabling Resources Program Scope: Phase 1

- The IESO will be implementing storage design through a phased approach.
- The intention of Phase 1 is to implement a fundamental design enabling storage participation in **Energy** and **OR** from both the injection and withdrawal ranges.
- The IESO will look to enhance the Phase 1 design in subsequent phases.

## Outcomes of Phase 1 Design

1. Single bi-directional resource model
2. State of Charge (SoC) management

## Enabling Resources Program Scope: Phase 2

- The IESO is in early stages of planning and design for Phase 2.
- Phase 2 scope includes enabling the IESO to access regulation service from battery storage facilities, implementing uplift exemptions for storage resources , and other enhancements to the Phase 1 design.
- Future engagements will provide further details on Phase 2 work and timelines.



# Benefits of Phase 1 Design

# Phase 1 Expected Benefits for Market Participants

This design that the IESO is bringing forward is expected to provide several benefits for MPs compared to the existing dual model resource design:

- **Flexibility and efficiency benefits** - fewer offer restrictions due to single resource model
  - Not restricted to generator/load dynamics and single sided OR offers
- **Market availability** - greater OR availability due to single resource model and SoC management
  - DSO co-optimizes OR for injection, withdrawal, and a new branching opportunity (withdrawal to injection).
- **Less manual interventions** – decreased need for the MP or the IESO to intervene and make last minute changes due to SoC management
  - DSO confirms feasibility for energy and OR schedules.

# Phase 1 Expected Benefits for Market Participants (cont)

- **Better opportunity to maximize usage and revenues** – SoC management better represents the capability of storage, providing additional scheduling opportunities.
  - Resources can utilize max injection capability in an interval and get to “zero” SoC faster. Today MPs ensure bids/offers submitted can be sustained for an hour essentially limiting max capability in that hour.
- **Outage management benefits** – Single resource model and SoC management provides the IESO with improved visibility in power and energy capability.
  - MPs can express energy impacts and power impacts to the facility to better utilize resource during outage conditions.
- **Market Power Mitigation improvements** – Updated MPM processes drive efficient outcomes by reinforcing cost-based competitive offers.
  - Accurately capture resource costs and opportunities resulting in improved scheduling outcomes



# Phase 1 Design Update Summary

## Updates to Phase 1, Batch 1 and 2

Updates to the Design Memos discussed during the October 16, 2025 (Batch 1, Optimization) and February 5, 2026 (Batch 2) engagement sessions are a result of one or more of the following:

- Stakeholder feedback via engagement and targeted outreach
- Further IESO analysis or clarification on the design
- Engagement with IESO solution vendors which required changes



# Optimization Design

# Updates on Optimization Design

- Parameter updates:
  - CycleDEL only utilized in DAM (removed from PD)
  - IESO defaulting of Internal Service Load (ISL) to zero MWh, this will have no impact on scheduling
  - Min/MaxSoC to hourly and SoC logic to account for anticipated change in range (upcoming slides describe logic change)
- Constraint violation pricing (CVP)
  - Absolute Min/Max CVPs \$95,000/MWh – included in scheduling passes, and pricing passes
  - Min/Max SoC CVPs - \$50,000/MWh – included in scheduling passes, and in pricing passes
  - CycleDEL CVP - \$36,000/MWh – included in scheduling, and in multi-interval pricing pass (not in the single interval pricing)

# Min/Max SoC Adjustment Without Logic

Resource has a 350 MWh SoC and a planned outage to reduce MaxSoC from 400 MWh to 300 MWh.

Without logic the engine will assume there is an impending condition that will assume the resource must be scheduled to inject 50 MWh to avoid bypassing the new MaxSoC limit of 300 MWh.

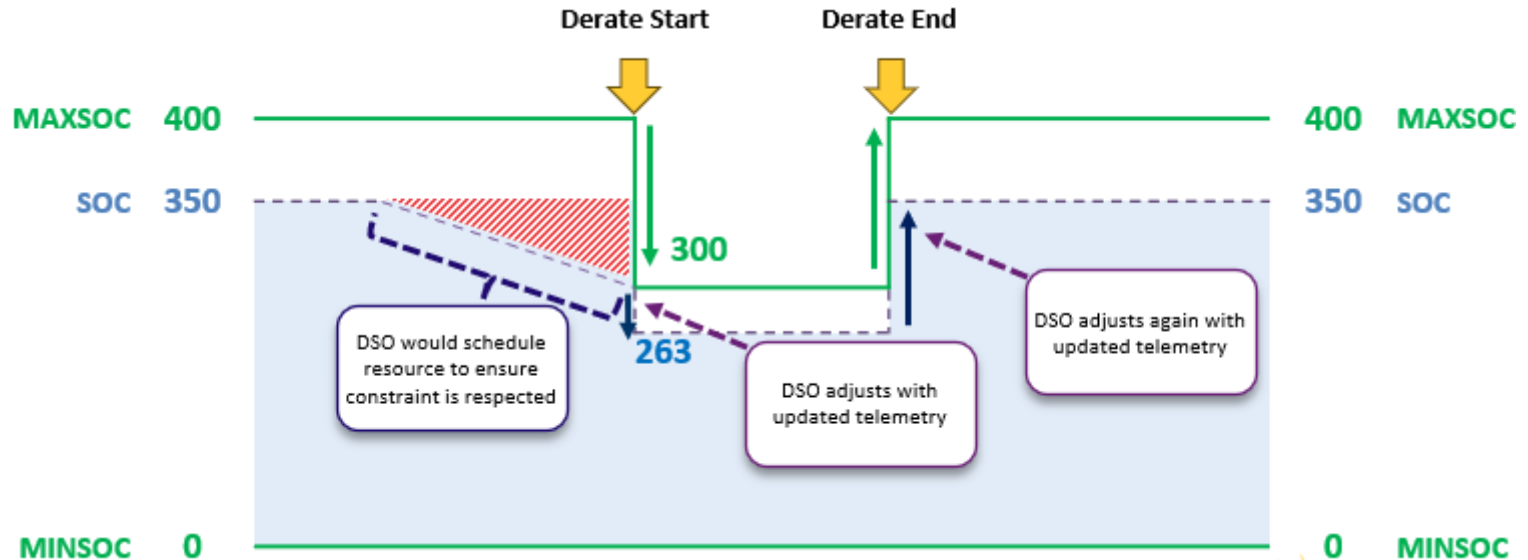

# Min/Max SoC Adjustment With Logic

Resource has a 350 MWh SoC and a planned outage to reduce MaxSoC from 400 MWh to 300 MWh. With Logic the resources SoC change is already accounted for in the look ahead period, therefore no unnecessary scheduling occurs.

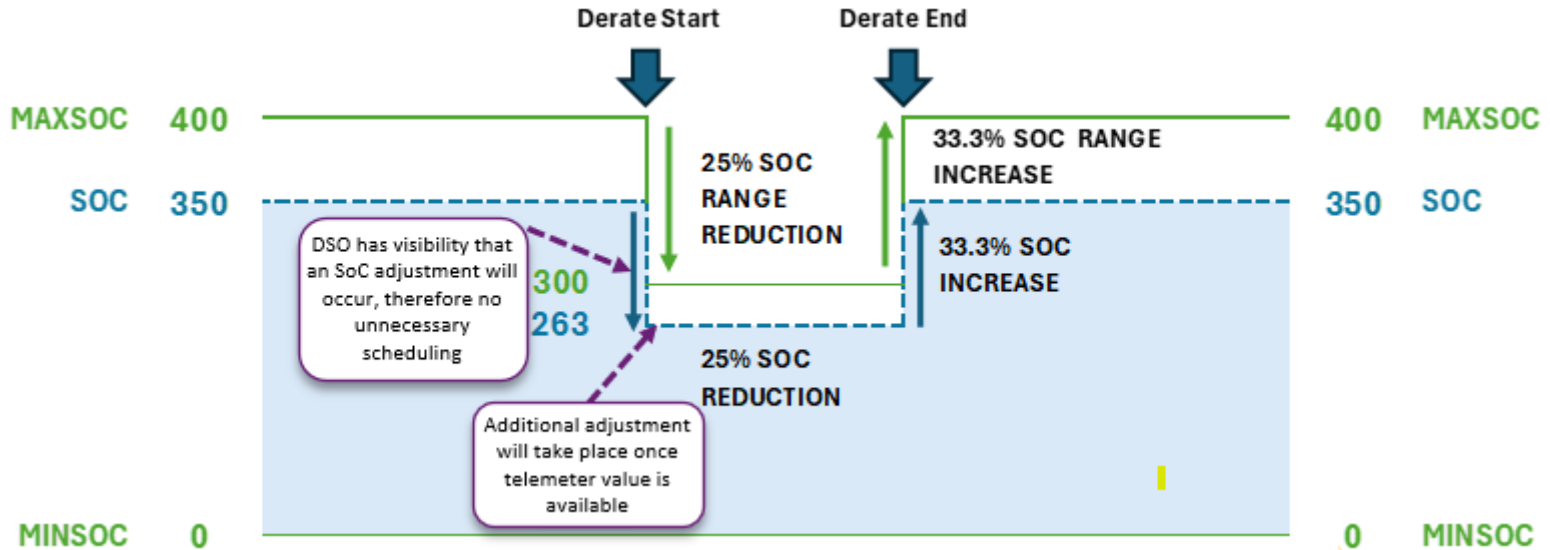

# Min/Max SoC Adjustment Logic

- MPs could have planned battery pack outages/changes requiring adjustments to Min/MaxSoC limits. ERP is introducing logic for DSO look ahead period calculations to ensure scheduling considers future state adjustments to actual state of charge when the range parameters are being adjusted.
- Logic supports:
  - Simulation of changes in SoC due to an outage
  - Avoids uneconomic scheduling that could be derived by the engine in lieu of logic.
- Please note: Multiple outage scenarios are not in-scope of phase 1 design.

# Telemetry to DSO Relationship

Telemetry is more impactful in scheduling for storage compared to other resources and critical in RT. To avoid unwanted dispatches, it is important that the resource and MP attempt to mirror DSO outcomes. Considerations include:

- **How cycle efficiency/losses are applied** – on the withdrawals, and discounting future injections.
- **Relating parameters and their adjustments to operation of facility** – ensure that SoC is within the Max/MinSoC limits.
- **Responding to dispatch** – the DSO assumes particular response and calculates SoC based on that.

# Telemetry to DSO Relationship (RT 5 min intervals)

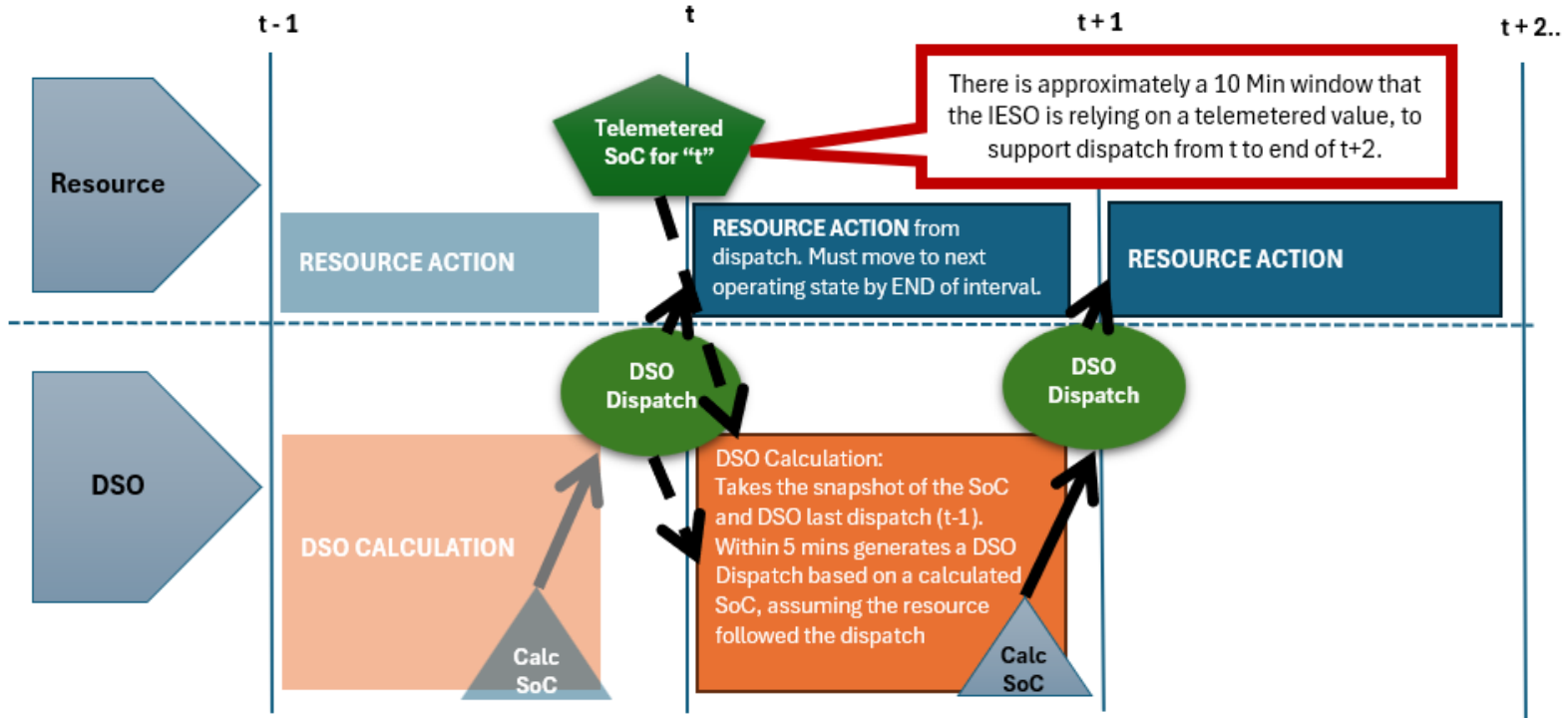



# Connection & Registration Design

# Connection Assessment

The “Connection” Process encompasses all processes and elements included in:

- Prepare Application
- Obtain Conditional Approval to Connect
- Design and Build

Since storage resources are already connecting to the ICG, **no changes are required** from the previous stakeholder engagement.

# Registration

The “Registration” Process encompasses:

- Register Organization & Authorize Participation
- Set/Maintain Prudential Support
- Register Facilities, Resources, and Equipment
- Record Equipment (minor changes)
- Prepare for Operations
- Wholesale Metering
- Build Online Model

No Other  
Changes  
Identified

# Connection and Registration Updates

Limited feedback pertinent to connection and registration; Feedback was generally seeking additional clarity.

The following updates have been made to the design:

- Removal of ISL to align with changes across other design elements. IESO will assign a default 0 value during registration.
- Commissioning section of the design has been expanded to provide additional insight into the self-scheduling process that has been developed.

# Recap: New Storage Registration Parameters

Parameter	Data Type (Value Range)	Summary
Bidirectional Resource Flag	Boolean (Y/N)	Indicates whether the resource can both inject and withdraw energy from the grid. This parameter, combined with the Energy Storage Flag, is required to participate as a SMSR.
Maximum Negative Generator Resource Active Power Capability	MW (-9999.9 to 0)	Defines the maximum charging (withdrawal) capability of the storage resource. This value is used to validate energy and operating reserve offers.
Cycle Efficiency	Decimal (0.00 to 1.00)	Represents the efficiency applied to charging energy to determine how much stored energy is available for later discharge. It supports accurate state of charge calculations and may be overridden through daily dispatch data submissions.

# Recap: New Storage Registration Parameters - SoC

Parameter	Data Type (Value Range)	Summary
Absolute Maximum State of Charge (Absolute MaxSoC)	MWh (0 to 9999.9)	Establishes the maximum energy level the battery may be charged to by the IESO. Hourly MaxSoC limits may be submitted below this value but cannot exceed it.
Absolute Minimum State of Charge (Absolute MinSoC)	MWh (0 to 9999.9)	Establishes the minimum energy level the battery may be discharged to by the IESO. Hourly MinSoC limits may be submitted above this value but cannot fall below it.
Minimum State of Charge (MinSoC)	MWh (0 to 9999.9)	Identifies the lowest energy level the battery can routinely reach without causing damage beyond normal degradation. This parameter is primarily informational and used to support internal validation.
Maximum State of Charge (MaxSoC)	MWh (0 to 9999.9)	Identifies the highest energy level the battery can routinely reach without causing damage beyond normal degradation. This parameter is primarily informational and used to support internal validation.



# Dispatch Data & Other Inputs Design

# Recap

This design element relates to inputs required by the IESO optimization engines, either from Market Participants (MPs) or from other IESO systems.

- **Daily dispatch parameters** – Data that is applicable for the entire dispatch day but can be updated through the course of the day if required (**Minimal changes**)
- **Hourly dispatch parameters** – Data that can vary from one dispatch hour such as energy or Operating Reserve bidirectional offers (**Minimal changes**)
- **Other MP inputs** – Information submitted in power outages or derates (**No changes**)
- **IESO inputs** – Demand forecasts, Market Power Mitigation (MPM) inputs, penalty pricing inputs, fundamental sets and location identifiers, resource min and max constraints entered by the IESO (**CVPs updated – already mentioned**)

# Daily Dispatch Parameters

- Dispatch data unique to single model storage resource submitted by MPs daily in DAM

Attribute	Unit of Measure	Description
<b>ISoC</b> <i>Initial State of Charge</i>	MWh (to one decimal place)	<ul style="list-style-type: none"> <li>Value should exclude all losses associated with withdrawal and injection</li> <li><b><u>Mandatory submission used by DAM only. IESO will not populate this for MPs.</u></b></li> </ul>
<b>Cycle Efficiency</b> <sup>^</sup> <i>Cycle Efficiency</i>	Decimal value (to two decimal places)	<ul style="list-style-type: none"> <li><b><u>Mandatory submission with a value between 0 and 1</u></b></li> </ul>
<del><b>ISL</b></del> <sup>*</sup> <del><i>Internal Service Load</i></del>	<del>MW</del> <del>(to one decimal place)</del>	<ul style="list-style-type: none"> <li><del><b><u>Value will default to 0 for Phase 1</u></b></del></li> </ul>
<b>CycleDEL</b> <i>Cycling Daily Energy Limit</i>	MWh (to one decimal place)	<ul style="list-style-type: none"> <li>Assist MP to avoid over-cycling battery if deemed necessary to avoid degradation</li> <li>Optional submission used by DAM <del>and PD</del></li> </ul>

Two changes

<sup>^</sup>Additional MPM validation against non-financial reference level (NFRL)

## Dispatch Data & Other Inputs Updates

- Removal of ISL to align with changes in optimization design. Value will default to 0 in scheduling engines; MPs will not be permitted to submit any ISL value as dispatch data.
- Min and MaxSoC confirmed as hourly parameters. MPs will be able to submit 24 Min and MaxSoC parameters.
- CycleDEL removed from PD. Submission will only be utilized in DAM, and any changes after DAM initiates will have no impact PD or RT results.



# Market Power Mitigation Design

# Recap

- MPM will **validate non-financial dispatch data submissions** against registered parameters in the ex-ante timeframe to prevent exercise of market power through operational parameters.
- **Ex-ante mitigation** will enable before-the-fact mitigation for the single model storage resources and address changes due to the bidirectional offer curve.
- **Settlement mitigation** will utilize mitigated bidirectional energy offer curve. Settlement mitigation will apply to the full resource operating reserve capability to branch from withdrawal to injection operations.
- After-the-fact **physical withholding** assessment may be triggered when submitted offer quantities are less than the applicable reference quantities.

# Summary of Changes: Market Power Mitigation

## What's Changing?

- ✓ Introduction of new non-financial dispatch data validations for SMSRs
- ✓ New financial reference level design for SMSRs
- ✓ Enhanced reference quantity design for SMSRs to assess physical withholding

## What's Not Changing?

- × Constrained area designations
- × Validation of existing dispatch data
- × Ex-ante mitigation testing conditions
- × Settlement mitigation testing conditions

# Focus Today on the Response to Stakeholder Feedback – MPM

- SMSR Financial Reference Level (FRL) design for energy and OR was developed with stakeholder input and is detailed in the latest MPM Design Memo.
- Feedback on ex-ante mitigation examples for energy have been addressed in the published design memo for MPM. There are no changes in the ex-ante mitigation design since the earlier engagement.
- There are no changes in validations, ex-post mitigation and settlement mitigation design since the earlier engagement.



# MPM Design - Financial Reference Level

## FRLs used for Ex-Ante Mitigation

- The IESO must establish Financial Reference Levels (FRLs) for **energy** and **OR** respectively before a dispatchable resource can participate in the energy and OR markets.
- For SMSRs, FRLs include energy offer Reference Levels (RLs) in \$/MWh for injection and OR offer RLs in \$/MW for each class of OR.
- **Energy offer FRLs** are established for injection only, which include two key components: charging cost and opportunity cost components.
- **OR offer FRLs** are established for the full capability of storage resources and include auxiliary energy consumption calculations.

# Energy Offer FRLs – Overview

- Energy offer FRLs will be created exclusively for the injection portion of the bi-directional offer curve.
- The MW range for the energy offer FRL will span from 0 to maximum generator resource active power capability.
- The energy offer FRLs will have a maximum of 18 price laminations, reserving space for withdrawal laminations if mitigation occurs.
- The energy offer reference level is calculated by taking the max of:
  1. (Charging Commodity Cost/Cycle Efficiency) + Non-Commodity Charges, and
  2. Opportunity Cost

# Energy Offer FRLs – Formula for Storage Resources

- The SMSR charging cost is the commodity cost of charging the battery.
- The SMSR opportunity cost is the forgone revenue of an hour's energy that could have been used in future when prices were maximized.
- The other components will be determined via consultation with MPs.

## *SMSR Energy Offer Reference Level*

$$\begin{aligned} &= \text{Max} \left( \left( \frac{\text{Charging Commodity Cost}}{\text{Cycle Efficiency}} \right) + \frac{\text{Charging Uplifts}}{\text{Cycle Efficiency}} \right. \\ &+ \frac{\text{Transmission and Distribution Charges}}{\text{Cycle Efficiency}} + \text{Global Adjustment} \\ &+ \text{Station Service Cost} + \text{Major Maintenance} \\ &+ \text{Scheduled Maintenance Electrical and Mechanical} \\ &\left. + \text{Unscheduled Maintenance Costs, (Battery Storage Opportunity Cost)} \right) \end{aligned}$$

# Energy Offer FRLs – Charging Cost

- **Charging commodity cost** captures costs associated with energy consumption for storage resources.
- Cycle Efficiency used in the energy offer RL will be sourced from MP-submitted daily dispatch data.
- The design for the dynamically calculated charging cost component for SMSR has been adopted from pumped hydro energy offer RL design, which takes a historical seven-day rolling average LMP from withdrawal operations.
- If no withdrawals are observed in the last 7 days, then previously calculated “charging commodity cost” is utilized.

$$\begin{aligned}
 & \text{Charging Commodity Cost} \left( \frac{\$}{MWh} \right) \\
 &= \frac{\sum_{n=1}^{r=1} \left( \sum_{2016}^{i=1} \left( \text{Charging Withdrawal Costs} \left( \frac{\$}{MWh} \right) \times \text{Scheduled Power (MWh)} \right)_i^{resource\ r} \right)}{\sum_{n=1}^{r=1} \left( \sum_{2016}^{i=1} \text{Scheduled Power (MWh)}_i^{resource\ r} \right)}
 \end{aligned}$$

## Energy Offer FRLs – Opportunity Cost

- **Opportunity cost** is the foregone revenue when a resource provides energy in the current timeframe instead of providing energy in a future hour.
- A new opportunity cost parameter is introduced for SMSRs, referred to as the **Battery Storage Opportunity Cost (BSOC)**.
- Four approaches are used to calculate BSOC. The DayAhead BSOC will be the maximum of approaches #1 and #2. The Realtime BSOC will be the maximum of all four approaches.

# Energy Offer FRLs – Opportunity Cost (cont.)

*DayAhead Battery Storage Opportunity Cost = MAX(OnPeak Historical Price, Historical RT Storage Horizon LMP)*

*Realtime Battery Storage Opportunity Cost = MAX(OnPeak Historical Price, Historical RT Storage Horizon LMP, Highest DayAhead LMP, Highest PD Advisory LMP)*

Approach	Name	DayAhead BSOC Calculation	Realtime BSOC Calculation
1	<b>OnPeak Historical Price</b>	Average hourly on-peak prices for the same week in the previous three years escalated using an electricity price index	Same as DayAhead Approach
2	<b>Historical RT Storage Horizon LMP</b>	Average of top historical hourly LMPs, ranked based on SoC hours, are forecasted for the storage duration (7 days) starting at the dispatch day	Same as DayAhead Approach but the SoC hours and LMPs used in the RT calculation may reflect more up-to-date information
3	<b>Highest DayAhead LMP</b>	N/A	Highest hourly LMP in the 24-hour DayAhead timeframe
4	<b>Highest PD Advisory LMP</b>	N/A	Highest pre-dispatch advisory market prices for next day (D+1)

# BSOC Approach #1 - OnPeak Historical Price

- BSOC Approach 1 determines the opportunity cost using the OnPeak historical prices from the past 3-years. The average of on-peak hourly (DA or RT) LMP is used for the average which is then escalated to price movements.

Let:

- $P_{y,h}$  = on-peak hourly price in year  $y$  and hour  $h$  of the same week
- On Peak = number of on-peak hours in that week

Step 1

$$Year\ 1\ OC_1 = \frac{1}{OnPeak} \sum_{h \in OnPeak} P_{1,h}$$

Step 2

$$Year\ 2\ OC_2 = \frac{1}{OnPeak} \sum_{h \in OnPeak} P_{2,h}$$

Step 3

$$Year\ 3\ OC_3 = \frac{1}{OnPeak} \sum_{h \in OnPeak} P_{3,h}$$

Step 4

$$OnPeak\ Historical\ Price = \frac{Year\ 1\ OC_1 + Year\ 2\ OC_2 + Year\ 3\ OC_3}{3}$$

Step 5

$$\begin{aligned} Approach\ 1\ Opportunity\ Cost &= OnPeak\ Historical\ Price \\ &\times MAX(1 + Approach\ 1\ Electricity\ Escalation\ Factor, 1) \end{aligned}$$

$$\begin{aligned} Approach\ 1\ Electricity\ Escalation\ Factor &= \frac{1}{2} \left( \left( \frac{Year\ 3\ OC_3 - Year\ 2\ OC_2}{Year\ 2\ OC_2} \right) + \left( \frac{Year\ 2\ OC_2 - Year\ 1\ OC_1}{Year\ 1\ OC_1} \right) \right) \end{aligned}$$

Average of on-peak hourly (DAM or RT) LMP from same week of last 3-years is used as potential opportunity cost

## BSOC Approach #2 - Historical RT Storage Horizon LMP

- BSOC Approach 2 determines the opportunity cost using the RT historical prices from the past 7 days or 168 hours.
- The average LMP of the highest X hours are chosen to be the opportunity cost.
- X represents the number of SoC hours and is determined by the nearest whole number (rounded down) to the ratio of the SoC in MWh and the Maximum Active Power Capability (MAPC) in MW.

Timeframe	Storage Duration	X Number of State of Charge Hours	DA Historical LMP	Ranking
Day Ahead	168 hours or 7 days	ROUNDDOWN (DA SoC MWh ÷ MAPC)	Lookback RT LMP from HE4 Int 12 of D0 to HE5 Int 1 of D-7	Rank and average the top 'X' SoC hourly LMPs as the opportunity cost value
Real Time	Same as Day Ahead	ROUNDDOWN (RT SoC MWh ÷ MAPC)	Lookback RT LMP from HE16 Int 12 of D0 to HE17 Int 1 of D-7	Same as Day Ahead

# BSOC Approach #3 - Highest Day-Ahead LMP

- The highest DA LMP from D+1 is used as potential opportunity cost for the real-time reference levels.

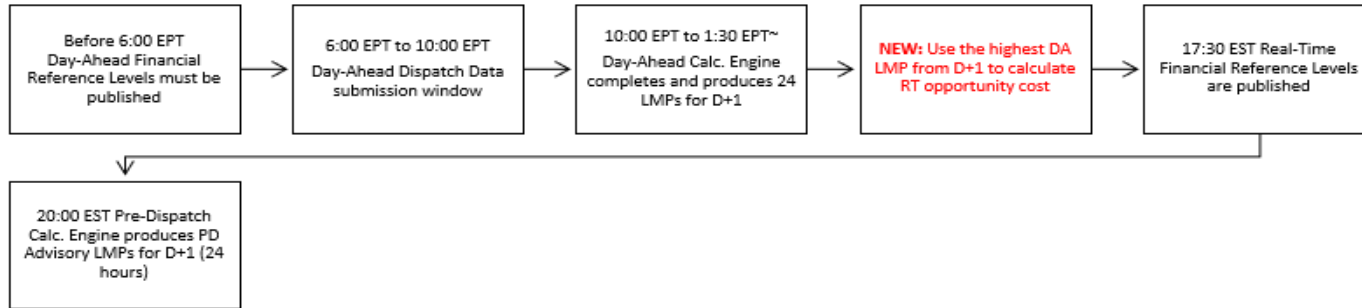

- This requires successful publication of DAM results. Otherwise, it is set to zero.

# BSOC Approach #4 - Highest PD Advisory LMP

- The highest PD Advisory LMP in D+1 is used as potential opportunity cost for the real-time reference levels.

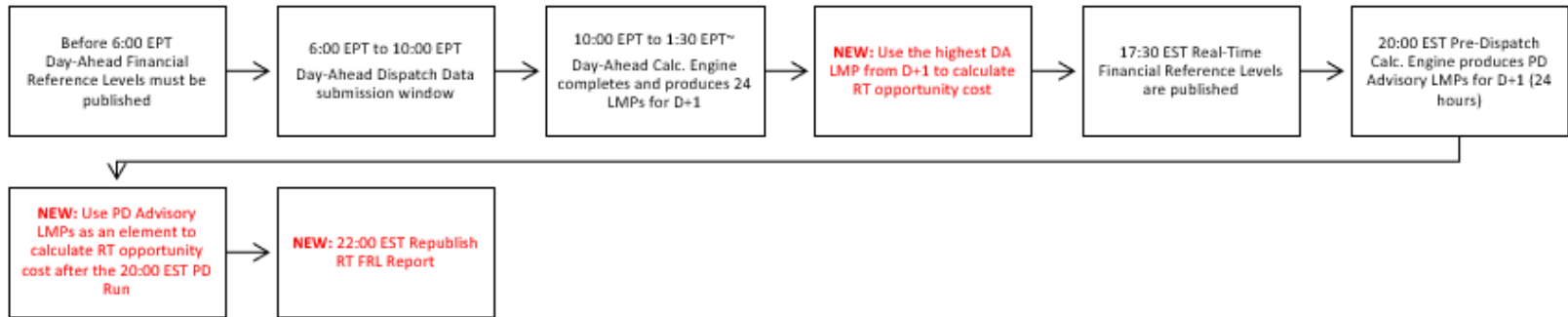

- This is used to update and publish a new version of RT FRLs for D+1. Note that exact timing of the solution is subject to implementation feasibility.

## OR Offer FRLs (10S, 10N, 30R)

- The OR offer for SMSR does not explicitly indicate which laminations correspond to charging or discharging, making a single-mode reference level necessary for simplicity and consistency.
- OR reference levels are based on costs associated with auxiliary energy consumption to position the resource in providing operating reserve across the charging and discharge operations.

# OR Offer FRLs – Auxiliary Energy Consumption

**Auxiliary energy consumption** determines the OR offer reference level and is the energy consumed by auxiliary services for the electricity storage resource to respond to dispatch instructions.

$$\text{Operating Reserve Incremental Cost} \left( \frac{\$}{MW} \right) = \text{Auxiliary Energy Consumption} \left( \frac{\$}{MW} \right)$$

$$\begin{aligned} & \text{Auxiliary Energy Consumption} \left( \frac{\$}{MW} \right) \\ &= \frac{\text{Auxiliary Power Consumed During 7 Day Operation (MWh)} \times 1\text{hour}}{7 \text{ Day MWh Scheduled on Operating Reserve (MWh)}} \times \text{Average Electricity Purchase Price} \left( \frac{\$}{MWh} \right) \end{aligned}$$

→ Fixed component

→ 7-day rolling dynamic components

# Temporary Reference Level Change Requests

- Submission of temporary fuel cost component change requests is a feature in the current MPM framework that enables Dispatch Data Submitter contact role to request temporary increase to a resource's reference levels for either DA or RT timeframe.
- Market participants have asked for requests to be applicable over multiple days and to enable the selection of more than one resource.
- As a result, the IESO will explore improving the submission process to enhance user-experience and efficiency of submissions, subject to implementation feasibility.



# Compliance Aggregation for SMSR

# Compliance Aggregation

- Compliance aggregation is a metering and settlement construct, where multiple resources can be assessed for compliance on an aggregate level.
- The IESO is assessing impact of design on SMSR facilities utilizing compliance aggregation. Once assessments are complete, ERP will inform the sector of relevant impacts.



# Day-in-the-Life Scenarios for SMSR

# Qualification statement

These Day-in-the-life examples are used for illustrative purposes only. Market prices and offers presented here are being used to display different functionality of the design and should not be assumed to be a true representation of market dynamics or market participant requirements.

# MP offers Example

Consider a resource with the following characteristics and strategy:

Example Bi-direction Energy offer with 9 laminations

P/Q Pair	Price (\$/MW)	Quantity (MW)	Price to Schedule (\$/MW)
Pair 1	-200	-200	-200 or less
Pair 2	-100	-90	-199.99 to -100
Pair 3	0	-80	-99.99 to 0
Pair 4	25	-50	0.01 to 25
Pair 5	100	0	25.01 to 99.99
Pair 6	100	50	100 to 499.99
Pair 7	500	100	500 to 599.99
Pair 8	600	150	600 to 699.99
Pair 9	700	200	700 or more

Example OR offer with 5 laminations

P/Q Pair	Price (\$/MW)	Quantity (MW)
Pair 1	0.1	0
Pair 2	0.1	50
Pair 3	5	80
Pair 4	10	200
Pair 5	10.01	400

Maximum Injection Rating

P <sub>MAX</sub>	200
P <sub>MIN</sub>	-200
MaxSoC	950
MinSoC	100
Cycle Efficiency	0.95
CycleDEL	800

Maximum Withdrawal Rating

Maximum SoC

Minimum SoC

Cycle Efficiency

Cycling Daily Energy Limit

# MP offers Example

\*The offers and prices in this example are exaggerated for effect; MPs will be mitigated by the MPM process

## Example Energy offer with 9 laminations

P/Q Pair	Price (\$/MW)	Quantity (MW)	Price to Schedule (\$/MW)	MP's Intended Action
Pair 1	-200	-200	-200 or less (more negative)	Charge 200MW if price is -\$200 or below
Pair 2	-100	-90	-199.99 to -100	Charge 90MW if the price is between -\$100 and -\$199.99
Pair 3	0	-80	-99.99 to 0	Charge 80MW if the price is between -\$99.99 and \$0
Pair 4	25	-50	0.01 to 25	Charge 50MW if the price is between \$0.01 and \$25
Pair 5	100	0	25.01 to 99.99	Do nothing if price is between \$25.01 and \$99.99
Pair 6	100	50	100 to 499.99	Inject 50MW if price is between \$100 and \$499.99
Pair 7	500	100	500 to 599.99	Inject 100MW if price is between \$500 and \$599.99
Pair 8	600	150	600 to 699.99	Inject 150MW if price is between \$600 and \$699.99
Pair 9	700	200	700	Inject 200MW if price is \$700 or above

Consider the following DAM prices; how will our battery be scheduled in the DAM based on these prices?

Hour Ending	HE1	HE2	HE3	HE4	HE5	HE6	HE7	HE8	HE9	HE10	HE11	HE12	HE13	HE14	HE15	HE16	HE17	HE18	HE19	HE20	HE21	HE22	HE23	HE24
DAM LMP	-\$ 10.00	-\$ 0.06	-\$ 200.00	-\$ 200.00	-\$ 200.00	\$ 5.00	\$ 10.00	\$ 15.00	\$ 15.00	\$ 30.00	\$ 500.00	\$ 500.00	\$ 550.00	\$ 550.00	\$ 600.00	\$ 650.00	\$ 710.00	\$ 500.00	-\$ 250.00	\$ 500.00	\$ 20.00	\$ 10.00	\$ 5.00	\$ 5.00
DAM ORLMP	\$ 0.10	\$ 15.00	\$ 0.10	\$ 0.10	\$ 15.00	\$ 15.00	\$ 1.00	\$ 1.00	\$ 1.00	\$ 10.00	\$ 10.00	\$ 15.00	\$ 15.00	\$ 4.00	\$ 15.00	\$ 10.00	\$ 10.00	\$ 4.00	\$ 4.00	\$ 4.00	\$ 4.00	\$ 4.00	\$ 4.00	\$ 4.00

# DAM Energy Schedule

Hour Ending	HE1	HE2	HE3	HE4	HE5	HE6	HE7	HE8	HE9	HE10	HE11	HE12	HE13	HE14	HE15	HE16	HE17	HE18	HE19	HE20
DAM LMP	-\$ 10.00	-\$ 0.06	-\$ 200.00	-\$ 200.00	-\$ 200.00	\$ 5.00	\$ 10.00	\$ 15.00	\$ 15.00	\$ 30.00	\$ 500.00	\$ 500.00	\$ 550.00	\$ 550.00	\$ 600.00	\$ 650.00	\$ 710.00	\$ 500.00	\$ 250.00	\$ 500.00

DAM ENERGY SCHEDULE	HE01	HE02	HE03	HE04	HE05	HE06	HE07	HE08	HE09	HE10	HE11	HE12	HE13	HE14	HE15	HE16	HE17	HE18	HE19	HE20
	-80.0	-50.0	-200.0	-200.0	-200.0	-50.0	-50.0	-50.0	0.0	0.0	0.0	100.0	100.0	100.0	150.0	150.0	200.0	0.0	-200.0	0.0

**STATE OF CHARGE (SoC) (beginning of hour)	100.0	176.0	223.5	413.5	603.5	793.5	841.0	888.5	936.0	936.0	936.0	936.0	836.0	736.0	636.0	486.0	336.0	136.0	136.0	326.0
*AVAILABLE SoC (beginning of hour)	0.0	76.0	123.5	313.5	503.5	693.5	741.0	788.5	836.0	836.0	836.0	836.0	736.0	636.0	536.0	386.0	236.0	36.0	36.0	226.0

Daily injection	0.0	0.0	0.0	0.0	0.0	0.0	0.0	0.0	0.0	0.0	0.0	100.0	200.0	300.0	450.0	600.0	800.0	800.0	800.0	800.0
CycleDEL Tracker (End of Hour)	800.0	800.0	800.0	800.0	800.0	800.0	800.0	800.0	800.0	800.0	800.0	700.0	600.0	500.0	350.0	200.0	0.0	0.0	0.0	0.0

This example discusses the effect of the following parameters:

- Cycle Efficiency (0.95)
- Energy scheduling
- CycleDEL effect

Hour Ending	HE11	HE12
DAM LMP	\$ 500.00	\$ 500.00
DAM ENERGY SCHEDULE	0.0	100.0
**STATE OF CHARGE (SoC) (beginning of hour)	936.0	936.0
*AVAILABLE SoC (beginning of hour)	836.0	836.0
Daily injection	0.0	100.0
CycleDEL Tracker (End of Hour)	800.0	700.0

Hour Ending	HE18
DAM LMP	\$ 500.00
DAM ENERGY SCHEDULE	0.0
**STATE OF CHARGE (SoC) (beginning of hour)	136.0
*AVAILABLE SoC (beginning of hour)	36.0

Daily injection	800.0
CycleDEL Tracker (End of Hour)	0.0

# Summary of outcomes

## In the DAM Energy Market:

- Cycle Efficiency is only applied on the withdrawal side; does consider losses on the injection.
- The engine may identify future opportunities and may save the resource for future hours as the cheapest overall solution.
- CycleDEL will limit energy injections, even if the resource is economic and has adequate SoC

# Energy and OR Co-optimization

Hour Ending	HE1	HE2	HE3	HE4	HE5	HE6	HE7	HE8	HE9	HE10	HE11	HE12	HE13	HE14	HE15	HE16	HE17	HE18	HE19	HE20
DAM LMP	-\$ 10.00	-\$ 0.06	-\$ 200.00	-\$ 200.00	-\$ 200.00	\$ 5.00	\$ 10.00	\$ 15.00	\$ 15.00	\$ 30.00	\$ 500.00	\$ 500.00	\$ 550.00	\$ 550.00	\$ 600.00	\$ 650.00	\$ 710.00	\$ 500.00	-\$ 250.00	\$ 500.00
DAM OR LMP	\$ 0.10	\$ 15.00	\$ 0.10	\$ 0.10	\$ 15.00	\$ 15.00	\$ 1.00	\$ 1.00	\$ 1.00	\$ 10.00	\$ 10.00	\$ 15.00	\$ 15.00	\$ 4.00	\$ 15.00	\$ 10.00	\$ 10.00	\$ 4.00	\$ 4.00	\$ 4.00

	HE01	HE02	HE03	HE04	HE05	HE06	HE07	HE08	HE09	HE10	HE11	HE12	HE13	HE14	HE15	HE16	HE17	HE18	HE19	HE20
DAM ENERGY SCHEDULE	-80.0	-50.0	-200.0	-200.0	-200.0	-50.0	-50.0	-50.0	0.0	0.0	0.0	100.0	100.0	100.0	150.0	150.0	200.0	0.0	-200.0	0.0
DAM OR SCHEDULE	50	126	50	50	400	250	50	50	50	200	200	100	100	50	50	50	0	0	50	0

**STATE OF CHARGE (SoC) (beginning of hour)	100.0	176.0	223.5	413.5	603.5	793.5	841.0	888.5	936.0	936.0	936.0	936.0	836.0	736.0	636.0	486.0	336.0	136.0	136.0	326.0
*AVAILABLE SoC (beginning of hour)	0.0	76.0	123.5	313.5	503.5	693.5	741.0	788.5	836.0	836.0	836.0	836.0	736.0	636.0	536.0	386.0	236.0	36.0	36.0	226.0

Daily injection	0.0	0.0	0.0	0.0	0.0	0.0	0.0	0.0	0.0	0.0	0.0	100.0	200.0	300.0	450.0	600.0	800.0	800.0	800.0	800.0
CycleDEL Tracker (End of Hour)	800.0	800.0	800.0	800.0	800.0	800.0	800.0	800.0	800.0	800.0	800.0	700.0	600.0	500.0	350.0	200.0	0.0	0.0	0.0	0.0

When co-optimizing for OR, the engine looks at the OR offers submitted and schedules the resource based on their SoC and scheduled action for that hour.

Based on the OR offers submitted on the right, co-optimized with our Energy offers, we receive the above Energy and OR schedule in the DAM.

## Example OR offer with 5 laminations

P/Q Pair	Price (\$/MW)	Quantity (MW)
Pair 1	0.1	0
Pair 2	0.1	50
Pair 3	5	80
Pair 4	10	200
Pair 5	10.01	400

# Energy and OR Co-optimization

Hour Ending	HE1	HE2	HE3	HE4	HE5	HE6	HE7	HE8	HE9	HE10	HE11	HE12	HE13	HE14	HE15	HE16	HE17	HE18	HE19	HE20
DAM LMP	-\$ 10.00	-\$ 0.06	-\$ 200.00	-\$ 200.00	-\$ 200.00	\$ 5.00	\$ 10.00	\$ 15.00	\$ 15.00	\$ 30.00	\$ 500.00	\$ 500.00	\$ 550.00	\$ 550.00	\$ 600.00	\$ 650.00	\$ 710.00	\$ 500.00	-\$ 250.00	\$ 500.00
DAM OR LMP	\$ 0.10	\$ 15.00	\$ 0.10	\$ 0.10	\$ 15.00	\$ 15.00	\$ 1.00	\$ 1.00	\$ 1.00	\$ 10.00	\$ 10.00	\$ 15.00	\$ 15.00	\$ 4.00	\$ 15.00	\$ 10.00	\$ 10.00	\$ 4.00	\$ 4.00	\$ 4.00

	HE01	HE02	HE03	HE04	HE05	HE06	HE07	HE08	HE09	HE10	HE11	HE12	HE13	HE14	HE15	HE16	HE17	HE18	HE19	HE20
DAM ENERGY SCHEDULE	-80.0	-50.0	-200.0	-200.0	-200.0	-50.0	-50.0	-50.0	0.0	0.0	0.0	100.0	100.0	100.0	150.0	150.0	200.0	0.0	-200.0	0.0
DAM OR SCHEDULE	50	126	50	50	400	250	50	50	50	200	200	100	100	50	50	50	0	0	50	0

**STATE OF CHARGE (SoC) (beginning of hour)	100.0	176.0	223.5	413.5	603.5	793.5	841.0	888.5	936.0	936.0	936.0	936.0	836.0	736.0	636.0	486.0	336.0	136.0	136.0	326.0
*AVAILABLE SoC (beginning of hour)	0.0	76.0	123.5	313.5	503.5	693.5	741.0	788.5	836.0	836.0	836.0	836.0	736.0	636.0	536.0	386.0	236.0	36.0	36.0	226.0

Daily injection	0.0	0.0	0.0	0.0	0.0	0.0	0.0	0.0	0.0	0.0	0.0	100.0	200.0	300.0	450.0	600.0	800.0	800.0	800.0	800.0
CycleDEL Tracker (End of Hour)	800.0	800.0	800.0	800.0	800.0	800.0	800.0	800.0	800.0	800.0	800.0	700.0	600.0	500.0	350.0	200.0	0.0	0.0	0.0	0.0

This example demonstrates the effects of OR scheduling and demonstrates how these resources can "branch".

Hour Ending	HE1	HE2	HE3	HE4	HE5	HE6
DAM LMP	-\$ 10.00	-\$ 0.06	-\$ 200.00	-\$ 200.00	-\$ 200.00	\$ 5.00
DAM OR LMP	\$ 0.10	\$ 15.00	\$ 0.10	\$ 0.10	\$ 15.00	\$ 15.00
DAM ENERGY SCHEDULE	-80.0	-50.0	-200.0	-200.0	-200.0	-50.0
DAM OR SCHEDULE	50	126	50	50	400	250
**STATE OF CHARGE (SoC) (beginning of hour)	100.0	176.0	223.5	413.5	603.5	793.5
*AVAILABLE SoC (beginning of hour)	0.0	76.0	123.5	313.5	503.5	693.5
Daily injection	0.0	0.0	0.0	0.0	0.0	0.0
CycleDEL Tracker (End of Hour)	800.0	800.0	800.0	800.0	800.0	800.0

# Energy and OR Co-optimization

Hour Ending	HE1	HE2	HE3	HE4	HE5	HE6	HE7	HE8	HE9	HE10	HE11	HE12	HE13	HE14	HE15	HE16	HE17	HE18	HE19	HE20
DAM LMP	-\$ 10.00	-\$ 0.06	-\$ 200.00	-\$ 200.00	-\$ 200.00	\$ 5.00	\$ 10.00	\$ 15.00	\$ 15.00	\$ 30.00	\$ 500.00	\$ 500.00	\$ 550.00	\$ 550.00	\$ 600.00	\$ 650.00	\$ 710.00	\$ 500.00	-\$ 250.00	\$ 500.00
DAM OR LMP	\$ 0.10	\$ 15.00	\$ 0.10	\$ 0.10	\$ 15.00	\$ 15.00	\$ 1.00	\$ 1.00	\$ 1.00	\$ 10.00	\$ 10.00	\$ 15.00	\$ 15.00	\$ 4.00	\$ 15.00	\$ 10.00	\$ 10.00	\$ 4.00	\$ 4.00	\$ 4.00

	HE01	HE02	HE03	HE04	HE05	HE06	HE07	HE08	HE09	HE10	HE11	HE12	HE13	HE14	HE15	HE16	HE17	HE18	HE19	HE20
DAM ENERGY SCHEDULE	-80.0	-50.0	-200.0	-200.0	-200.0	-50.0	-50.0	-50.0	0.0	0.0	0.0	100.0	100.0	100.0	150.0	150.0	200.0	0.0	-200.0	0.0
DAM OR SCHEDULE	50	126	50	50	400	250	50	50	50	200	200	100	100	50	50	50	0	0	50	0

**STATE OF CHARGE (SoC) (beginning of hour)	100.0	176.0	223.5	413.5	603.5	793.5	841.0	888.5	936.0	936.0	936.0	936.0	836.0	736.0	636.0	486.0	336.0	136.0	136.0	326.0
*AVAILABLE SoC (beginning of hour)	0.0	76.0	123.5	313.5	503.5	693.5	741.0	788.5	836.0	836.0	836.0	836.0	736.0	636.0	536.0	386.0	236.0	36.0	36.0	226.0

Daily injection	0.0	0.0	0.0	0.0	0.0	0.0	0.0	0.0	0.0	0.0	0.0	100.0	200.0	300.0	450.0	600.0	800.0	800.0	800.0	800.0
CycleDEL Tracker (End of Hour)	800.0	800.0	800.0	800.0	800.0	800.0	800.0	800.0	800.0	800.0	800.0	700.0	600.0	500.0	350.0	200.0	0.0	0.0	0.0	0.0

This example demonstrates the effects of SoC and CycleDEL on OR scheduling in the DAM

Hour Ending	HE16	HE17	HE18
DAM LMP	\$ 650.00	\$ 710.00	\$ 500.00
DAM OR LMP	\$ 10.00	\$ 10.00	\$ 4.00
DAM ENERGY SCHEDULE	150.0	200.0	0.0
DAM OR SCHEDULE	50	0	0
**STATE OF CHARGE (SoC) (beginning of hour)	486.0	336.0	136.0
*AVAILABLE SoC (beginning of hour)	386.0	236.0	36.0
Daily injection	600.0	800.0	800.0
CycleDEL Tracker (End of Hour)	200.0	0.0	0.0

# Summary of outcomes

When co-optimizing Energy and OR:

- The SoC is included in the co-optimization process, where feasibility will be confirmed for both energy dispatch and OR schedules.
- CycleDEL will limit how much OR a resource can provide via injection in DAM but **will not** limit OR provided through withdrawal in DAM.

# RT Operation

- Storage resources that are economic in RT intervals will be dispatched regardless of their DAM or PD schedules as SMSRs do not have any DAM or PD commitments. To ensure the resource will be utilized effectively, it is up to the MP to update offers to reflect changing system conditions, or the control room to constrain the resource (will limit energy and OR).
  - MPs must manage their two-settlement risk because of interval price changes, and how their SoC may need to be preserved to avoid economic loss.
- CycleDEL is not considered in RT. A resource may be dispatched beyond its CycleDEL if the engine determines that the resource has the available SoC. SoC will be provided by telemetry.
- RT telemetry is utilized by the DSO for each interval to address differences in SoC calculation due to Ramp, Cycle Efficiency and other dispatch effects.

# RT Snapshot

Consider the period below (HE9 INT11 – HE11 INT5)

DAM Schedule			
Hour Ending	HE9	HE10	HE11
DAM LMP	\$ 15.00	\$ 30.00	\$ 500.00
DAM OR LMP	\$ 1.00	\$ 10.00	\$ 10.00

DAM Schedule			
	HE09	HE10	HE11
DAM ENERGY SCHEDULE	0.0	0.0	0.0
DAM OR SCHEDULE	50	200	200

**STATE OF CHARGE (SoC) (beginning of hour)	936.0	936.0	936.0
*AVAILABLE SoC (beginning of hour)	836.0	836.0	836.0

Hour Ending	HE9		HE10						HE11												
	INT11	INT12	INT1	INT2	INT3	INT4	INT5	INT6	INT7	INT8	INT9	INT10	INT11	INT12	INT1	INT2	INT3	INT4	INT5	INT6	
RT LMP	\$ 15.00	\$ 15.00	\$ 30.00	\$ 30.00	\$ 30.00	\$ 30.00	\$ 30.00	\$ 30.00	\$ 500.00	\$ 500.00	\$ 500.00	\$ 500.00	\$ 500.00	\$ 500.00	\$ 500.00	\$ 500.00	\$ 500.00	\$ 500.00	\$ 500.00	\$ 500.00	\$ 500.00
RT OR LMP	\$ 1.00	\$ 1.00	\$ 10.00	\$ 10.00	\$ 10.00	\$ 10.00	\$ 10.00	\$ 10.00	\$ 10.00	\$ 10.00	\$ 10.00	\$ 10.00	\$ 10.00	\$ 10.00	\$ 10.00	\$ 10.00	\$ 10.00	\$ 10.00	\$ 10.00	\$ 10.00	\$ 10.00
ENERGY SCHEDULE	0.0	0.0	0.0	0.0	0.0	0.0	0.0	0.0	100.0	100.0	100.0	100.0	100.0	100.0	100.0	100.0	100.0	100.0	100.0	100.0	100.0
OR SCHEDULE	50	50	200	200	200	200	200	200	100	100	100	100	100	100	100	100	100	100	100	100	100
**STATE OF CHARGE (SoC)	936.0	936.0	936.0	936.0	936.0	936.0	936.0	936.0	936.0	927.7	919.3	911.0	902.7	894.3	886.0	877.7	869.3	861.0	852.7	844.3	
*AVAILABLE SoC (beginning of Interval)	836.0	836.0	836.0	836.0	836.0	836.0	836.0	836.0	836.0	827.7	819.3	811.0	802.7	794.3	786.0	777.7	769.3	761.0	752.7	744.3	

This example provides a snapshot of a situation where a resource has not updated their offers, and is scheduled outside of their DAM schedule in RT.

# RT Snapshot

Consider the period below (H15 INT11 – HE17 INT6)

DAM Schedule			
Hour Ending	HE15	HE16	HE17
DAM LMP	\$ 600.00	\$ 650.00	\$ 710.00
DAM OR LMP	\$ 15.00	\$ 10.00	\$ 10.00

	HE15	HE16	HE17
DAM ENERGY SCHEDULE	150.0	150.0	200.0
DAM OR SCHEDULE	50	50	0

**STATE OF CHARGE (SoC) (beginning of hour)	642.1	488.2	334.3
*AVAILABLE SoC (beginning of hour)	542.1	388.2	234.3

Hour Ending	HE15		HE16														HE17			
	INT11	INT12	INT1	INT2	INT3	INT4	INT5	INT6	INT7	INT8	INT9	INT10	INT11	INT12	INT1	INT2	INT3	INT4	INT5	INT6
RT LMP	\$ 600.00	\$ 600.00	\$ 650.00	\$ 650.00	\$ 650.00	\$ 650.00	\$ 650.00	\$ 650.00	\$ 650.00	\$ 650.00	\$ 650.00	\$ 650.00	\$ 650.00	\$ 650.00	\$ 710.00	\$ 710.00	\$ 400.00	\$ 300.00	\$ 200.00	\$ 100.00
RT OR LMP	\$ 1.00	\$ 1.00	\$ 10.00	\$ 10.00	\$ 10.00	\$ 10.00	\$ 10.00	\$ 10.00	\$ 10.00	\$ 10.00	\$ 10.00	\$ 10.00	\$ 10.00	\$ 10.00	\$ 10.00	\$ 10.00	\$ 10.00	\$ 10.00	\$ 10.00	\$ 10.00

ENERGY SCHEDULE	150.0	150.0	150.0	150.0	150.0	150.0	150.0	150.0	150.0	150.0	150.0	150.0	150.0	150.0	200.0	148.0	0.0	0.0	0.0	0.0
OR SCHEDULE	41.5	29.0	16.5	4.0	0	0	0	0	0	0	0	0	0	0	0	0	0	0	0	0

**STATE OF CHARGE (SoC)	304.0	291.5	279.0	266.5	254.0	241.5	229.0	216.5	204.0	191.5	179.0	166.5	154.0	141.5	129.0	112.3	100.0	100.0	100.0	100.0
*AVAILABLE SoC (beginning of Interval)	204.0	191.5	179.0	166.5	154.0	141.5	129.0	116.5	104.0	91.5	79.0	66.5	54.0	41.5	29.0	12.3	0.0	0.0	0.0	0.0

This example provides a snapshot of a situation where a resource has not updated their offers, and the effect this can have on their SoC throughout the day.

# Summary of outcomes

## When Operating in RT:

- SMSRs are not committed (i.e., considered quick start resources), therefore RT will not constrain the resource to their DAM schedules. If a resource would like to operate in accordance with their DAM schedule, MPs may need to update their offers in pre-dispatch to ensure an economic schedule in RT.
- SoC feasibility for energy and OR considers the RT interval that the resource received the dispatch and the additional hour-long requirement for an OR activation.

## Note on Uneconomic Scheduling

Resources may be scheduled uneconomically for several reasons:

- Control room manual intervention (e.g. IESO needs to preserve SoC for an emergent reliability need)
- DSO decides uneconomic schedule is lowest cost solution (charge uneconomically, to derive a lower cost injection relative to the next marginal resource) and also considering constraint violation pricing
- MPs submissions result in a conflict with constraints, e.g. telemetered SoC is outside of SoC range.



# Next Steps and Feedback

## Next steps

- Today's engagement session concludes engagement on design modules in scope for Phase 1 of the ERP Storage Integration Project.
- The next phase of engagement will focus on the proposed market rule amendments, beginning the implementation and execution phase which includes the IESO Technical Panel review of those rules.
- To support that phase of the project, additional "Day-in-the-Life" scenarios will be included during the review of the proposed rules, along with insight into other implementation processes and activities.

## Next steps: Day-in-the-Life Scenarios

- The IESO is considering the following scenarios and is open to feedback on other areas of interest to participants via today's feedback form:
  - Compliance Aggregation examples
  - Telemetry in relation to DSO scheduling process
  - Adjustments in Max/Min SoC
  - Different OR scheduling scenarios – generation or withdrawal only, and branching

# Feedback

- Feedback is an important IESO engagement principal to ensure that sector input and perspectives are considered.
- The IESO is requesting written feedback on today's session via the **IESO's Feedback Form** (available on the [ERP Storage webpage](#))
  - Feedback is being requested by **June 5, 2026**
- Please submit to IESO Engagement [engagement@ieso.ca](mailto:engagement@ieso.ca)

---

# Thank You

[ieso.ca](http://ieso.ca)

1.888.448.7777

[customer.relations@ieso.ca](mailto:customer.relations@ieso.ca)

[engagement@ieso.ca](mailto:engagement@ieso.ca)



[@IESO Tweets](https://twitter.com/IESO)



[facebook.com/OntarioIESO](https://facebook.com/OntarioIESO)



[linkedin.com/company/IESO](https://linkedin.com/company/IESO)