

WEST OF THUNDER BAY SUB-REGION INTEGRATED REGIONAL RESOURCE PLAN

Part of the Northwest Ontario Planning Region | July 27, 2016



Integrated Regional Resource Plan

West of Thunder Bay

This Integrated Regional Resource Plan (“IRRP”) was prepared by the Independent Electricity System Operator (“IESO”) pursuant to the terms of its Ontario Energy Board electricity licence, EI-2013-0066.

This IRRP was prepared on behalf of the West of Thunder Bay Sub-region Working Group (the “Working Group”), which included the following members:

- Independent Electricity System Operator
- Hydro One Networks Inc. (Distribution)
- Hydro One Networks Inc. (Transmission)
- Fort Frances Power Corporation
- Atikokan Hydro Inc.
- Kenora Hydro Electric Corporation Ltd.
- Sioux Lookout Hydro Inc.

The Working Group assessed the reliability of electricity supply to customers in the West of Thunder Bay Sub-region over a 20-year period; developed a flexible, comprehensive, integrated plan that considers opportunities for coordination in anticipation of potential demand growth scenarios and varying supply conditions in the West of Thunder Bay Sub-region; and developed an implementation plan for the recommended options, while maintaining flexibility in order to accommodate changes in key assumptions over time.

The Working Group members agree with the IRRP’s recommendations and support implementation of the plan, subject to obtaining necessary regulatory approvals. Where growth in the sub-region is directly related to potential large industrial developments, the onus lies with those developers to initiate the implementation of the plan.

Copyright © 2016 Independent Electricity System Operator. All rights reserved.

Table of Contents

| | |
|--|-----------|
| 1. Introduction..... | 1 |
| 2. The Integrated Regional Resource Plan..... | 4 |
| The 20-Year Plan (2015-2034)..... | 4 |
| 3. Development of the Integrated Regional Resource Plan..... | 7 |
| 3.1 The Regional Planning Process | 7 |
| 3.2 The IESO's Approach to Integrated Regional Resource Planning | 10 |
| 3.3 West of Thunder Bay Sub-region Working Group and IRRP Development | 11 |
| 4. Background and Study Scope | 13 |
| 4.1 West of Thunder Bay - Study Scope | 13 |
| 4.2 West of Thunder Bay Electricity System..... | 15 |
| 4.2.1 Local Generation Resources | 16 |
| 4.2.2 Transmission System..... | 18 |
| 4.2.3 Distribution System | 20 |
| 5. Demand Forecast | 22 |
| 5.1 Historical Electricity Demand 2004-2014 | 22 |
| 5.2 Methodology for Establishing Planning Forecast Scenarios | 23 |
| 5.3 Development of Planning Forecast..... | 24 |
| 5.3.1 Gross Demand Forecast Scenarios..... | 24 |
| 5.3.2 Expected Peak Demand Savings from Provincial Conservation Targets | 25 |
| 5.3.3 Expected Peak Demand Contribution of Existing and Contracted Distributed Generation..... | 27 |
| 5.3.4 Planning Forecast..... | 27 |
| 5.4 Potential Growth in the North of Dryden Sub-region | 29 |
| 6. Needs | 30 |
| 6.1 Needs Assessment Methodology | 30 |
| 6.2 Regional Electricity Reliability Needs | 31 |
| 6.2.1 Potential Supply Capacity Need on the Dryden 115 kV Sub-system..... | 31 |
| 6.2.2 Transformer Station Capacity Needs in the Kenora area..... | 32 |
| 6.2.3 Transmission End-of-Life Replacements and Sustainment Activities | 33 |
| 6.2.4 Transmission Service Reliability and Performance..... | 33 |

| | | |
|------------|---|-----------|
| 6.3 | Other Electricity Needs and Considerations | 34 |
| 6.3.1 | 230 kV Bulk System Needs | 35 |
| 6.3.2 | Distribution System Needs | 37 |
| 6.3.3 | Community Energy Planning | 38 |
| 6.4 | Needs Summary | 39 |
| 7. | Options to Address Potential Regional and Local Needs..... | 42 |
| 7.1 | Options to Address Supply Capacity Needs on Dryden 115 kV Sub-system under the High Scenario..... | 43 |
| 7.1.1 | Conservation and Distributed Energy Resources | 43 |
| 7.1.2 | Large, Localized Generation Resources..... | 44 |
| 7.1.3 | Delivering Provincial Resources (“Wires” Planning)..... | 45 |
| 7.2 | Opportunities to Further Improve Service Reliability | 46 |
| 7.3 | Potential Areas for Coordination: Community Energy Planning and Regional Planning Activities | 47 |
| 8. | Recommended Actions..... | 48 |
| 9. | Community and Stakeholder Engagement | 50 |
| 9.1 | Creating Transparency | 51 |
| 9.2 | Engage Early and Often..... | 52 |
| 9.2.1 | Northwest Ontario Scoping Assessment Outcome Report..... | 52 |
| 9.2.2 | First Nation and Métis Community Meetings..... | 52 |
| 9.2.3 | Municipal Meetings..... | 53 |
| 9.3 | Bringing Communities to the Table..... | 53 |
| 9.4 | Additional Meetings and Presentations..... | 54 |
| 10. | Conclusion | 56 |

List of Figures

- Figure 3-1: Levels of Electricity System Planning 9
- Figure 3-2: Steps in the IRRP Process 11
- Figure 3-3: Northwest Ontario Region and Sub-regions..... 12
- Figure 4-1: Geographical Boundaries of the West of Thunder Sub-region..... 13
- Figure 4-2: Installed Capacity of Generation Resources in the West of Thunder Bay Sub-region (MW)..... 16
- Figure 4-3: West of Thunder Bay Sub-region – Transmission System 18
- Figure 4-4: Regional 115 kV Sub-systems in the West of Thunder Bay Sub-region 19
- Figure 4-5: Local Distribution Companies (LDCs) Service Area..... 21
- Figure 5-1: West of Thunder Bay Sub-region Historical Peak Demand (2004-2014)..... 23
- Figure 5-2: Categories of Conservation Savings..... 26
- Figure 5-3: Planning Forecast Scenarios 28
- Figure 6-1: Electricity Planning at the Bulk, Regional, Distribution and Community Levels 35
- Figure 6-2: 230 kV Supply into West of Thunder Bay and North of Dryden Sub-regions 36

List of Tables

| | |
|---|----|
| Table 6-1: Summary of Regional Supply and Reliability Needs | 39 |
| Table 6-2: Other Electricity Needs and Considerations in the area | 40 |
| Table 8-1: Recommended Actions | 49 |

List of Appendices

Appendix A: Demand Forecasting – Methodology and Assumptions

Appendix B: Needs Assessment

Appendix C: K3D and F2B Reliability Performances

Appendix D: Distribution Reliability Performances

Appendix E: Moose Lake Transformer Station End-of-Life Replacements

Appendix F: Local Advisory Committee Meeting Summaries

List of Abbreviations

| | |
|---------------------|---|
| | |
| Atikokan Hydro | Atikokan Hydro Inc. |
| CDM or Conservation | Conservation and Demand Management |
| CEP | Community Energy Plan(s) |
| CFF | Conservation First Framework |
| CHP | Combined Heat and Power |
| C&S | Codes and Standards |
| DR | Demand Response |
| DG | Distributed Generation |
| EA | Environmental Assessment |
| EE | Energy Efficiency |
| Fort Frances Power | Fort Frances Power Corporation |
| GHG | Greenhouse Gas |
| Hydro One | Hydro One Networks Inc. |
| IAP | Industrial Accelerator Program |
| ICI | Industrial Conservation Initiative |
| IESO | Independent Electricity System Operator |
| IRRP | Integrated Regional Resource Plan |
| Kenora Hydro | Kenora Hydro Electric Corporation Ltd. |
| kV | Kilovolt |
| kW | Kilowatt |
| LAC or Committee | Local Advisory Committee |
| LDC | Local Distribution Company |
| LMC | Load Meeting Capability |
| LTEP | Long-Term Energy Plan |
| MW | Megawatt |
| NERC | North American Electric Reliability Corporation |
| NPCC | Northeast Power Coordinating Council |
| OEB or Board | Ontario Energy Board |

| | |
|---------------------|--|
| | |
| OPA | Ontario Power Authority |
| ORTAC | Ontario Resource and Transmission Assessment Criteria |
| PPWG | Planning Process Working Group |
| PPWG Report | Planning Process Working Group Report to the Board |
| RIP | Regional Infrastructure Plan |
| SAIDI | System Average Interruption Duration Index |
| SAIFI | System Average Interruption Frequency Index |
| Sioux Lookout Hydro | Sioux Lookout Hydro Inc. |
| TOU | Time-of-Use |
| TS | Transformer Station |
| TWh | Terawatt Hours |
| Working Group | Technical Working Group for the West of Thunder Bay IRRP |
| QUEST | Quality Urban Energy Systems of Tomorrow |

1. Introduction

This Integrated Regional Resource Plan (“IRRP”) for the West of Thunder Bay Sub-region addresses the electricity needs for the sub-region over the next 20 years (“study period”) from 2015-2034. The IRRP was prepared by the Independent Electricity System Operator (“IESO”) on behalf of the Technical Working Group (the “Working Group”) for the West of Thunder Bay Sub-region composed of the IESO, Hydro One Networks Inc. (Hydro One Distribution and Hydro One Transmission¹), Atikokan Hydro Inc. (“Atikokan Hydro”), Kenora Hydro Electric Corporation Ltd. (“Kenora Hydro”), Fort Frances Power Corporation (“Fort Frances Power”), and Sioux Lookout Hydro Inc. (“Sioux Lookout Hydro”).

The area covered by the West of Thunder Bay IRRP is a sub-region of the Northwest Ontario Region identified through the Ontario Energy Board (“OEB” or “Board”) regional planning process. This sub-region is defined as the area bordered to the south and west by the United States and Manitoba borders respectively, and extending north to include the City of Kenora, the City of Dryden and the Municipality of Sioux Lookout, and east as far as (but not including) the City of Thunder Bay, and does not include the area North of Dryden. This sub-region is characterized by:

- **Diverse communities:** In addition to the “unorganized areas”² in the Kenora and Rainy River Districts, there are 26 First Nation communities and 16 municipalities included in this sub-region, all of which are listed in Section 4.1. Each community has local priorities and distinct electricity needs. Many of these communities are engaging in community energy planning activities.
- **Mining, pulp and paper and other industrial developments:** Industrial customers are major electricity consumers in this sub-region and are sensitive to varying economic conditions, such as commodity price and changes in economic growth. Often these factors can lead to material changes in their annual electricity demand and uncertainty in the sub-region’s electricity demand forecast.
- **Large geographical area:** Long and expansive transmission and distribution infrastructure is required to bring electricity supply to the various communities and customers across this sub-region. The geography and sparsely populated areas make it challenging and costly to develop and maintain infrastructure.

¹ For the purpose of this report, “Hydro One Transmission” and “Hydro One Distribution” are used to differentiate the transmission and distribution accountabilities of Hydro One Networks Inc., respectively.

² Unorganized areas are parts of the province where there is no municipal level of government. Services in these unorganized districts are typically administered by local service boards.

- **Complex electricity infrastructure network:** The sub-region's electricity system is comprised of a 230 kilovolt ("kV") bulk system, 115 kV regional system, local distribution networks and variable, local generation resources. The system is interconnected with Manitoba and Minnesota. This system not only supplies the communities and customers in the West of Thunder Bay Sub-region, it also provides an important source of supply to the North of Dryden Sub-region. The interactions between these interconnections and the bulk, regional and distribution network will have an impact on the reliability of supply for the West of Thunder Bay Sub-region.

This IRRP took into consideration the characteristics discussed above. Given the uncertainties associated with the timing and magnitude of potential industrial developments, the Working Group identified regional electricity needs and solutions under three demand forecast scenarios (Reference, High and Low) as described in Section 5.3.4., and developed a flexible, comprehensive, integrated plan to accommodate these potential scenarios. The challenges, costs and lead times required to develop and maintain infrastructure in this sub-region were also taken into consideration in the development of the plan.

The primary focus of this IRRP is to identify and address electricity reliability needs on the 115 kV regional transmission systems in the sub-region. Given the complex nature of the electricity system and the diverse needs in this sub-region, bulk, distribution and community energy planning activities are also underway. To facilitate coordination of the various electricity planning activities in this sub-region, this IRRP also documents and considers bulk and distribution system needs and community planning activities. Section 3 describes the types of electricity planning in Ontario and the linkages between them, as well as, how important it is to coordinate regional planning with bulk and distribution system and community energy planning.

This IRRP fulfills the requirements for the sub-region as required by the IESO's OEB electricity licence. IRRPs are required to be reviewed on a 5-year cycle so that plans can be updated to reflect the changing electricity outlook. This IRRP will be revisited in 2021, or earlier if significant changes occur relative to the current forecast.

This IRRP report is organized as follows:

- A summary of the recommended plan for the West of Thunder Bay Sub-region is provided in Section 2;
- The process used to develop the plan is discussed in Section 3;

- The context for electricity planning in the West of Thunder Bay and the study scope are discussed in Section 4;
- Demand forecast scenarios, and conservation and demand management (“CDM” or “conservation”) and distributed generation (“DG”) assumptions are described in Section 5;
- Needs in West of Thunder Bay are presented in Section 6;
- Options to address regional and local needs are addressed in Section 7;
- Recommended actions are set out in Section 8;
- A summary of community, indigenous and stakeholder engagement to date is provided in Section 9; and
- A conclusion is provided in Section 10.

2. The Integrated Regional Resource Plan

The West of Thunder Bay IRRP addresses the sub-region's electricity needs over the next 20 years, based on application of the IESO's Ontario Resource and Transmission Assessment Criteria ("ORTAC"). The IRRP was developed in consideration of a number of factors, including reliability, cost, technical feasibility and also the diverse needs and unique characteristics of the sub-region. Given the uncertainty associated with the demand forecast, the Working Group identified regional electricity needs and solutions under various demand scenarios and developed a flexible, comprehensive, integrated plan for these varying conditions.

In addition to regional planning, bulk, distribution and community energy planning activities are also underway in the sub-region. While these activities are beyond the scope of the regional planning process, they were identified and taken in consideration in the development of this IRRP.

The needs and recommended actions are summarized below.

The 20-Year Plan (2015-2034)

Aside from the potential need for additional supply on the 230 kV bulk transmission system, the Working Group did not identify any major regional 115 kV supply and reliability needs in the West of Thunder Bay Sub-region under Low and Reference scenarios. Under the High scenario, there is the potential need for an additional 50 MW of supply on the Dryden 115 kV sub-system.

Given the uncertainty with the location, timing and magnitude of demand growth, early development work for major infrastructure projects is not required at this time. Instead, the Working Group has sought to lay the ground work for the next planning cycle by exploring potential options for the Dryden 115 kV sub-system and monitoring demand growth closely to determine if and when an investment decision on the Dryden 115 kV sub-system would be required. End-of-life replacements/sustainment activities and transformer station capacity needs were also identified in this area, but these are not expected to have regional implications. Options to address the 230 kV bulk transmission system needs are being considered as part of the bulk system planning process led by the IESO.

In this sub-region, many communities and customers are supplied by long transmission and distribution networks and rely on a single supply source. They are concerned about service

reliability and performance. The transmission and distribution service reliability performances of the West of Thunder Bay Sub-region are within the provincial service reliability and performance standards. Communities and customers may consider working with Hydro One Transmission and local distribution companies (“LDCs”) to explore opportunities to further improve transmission and distribution service reliability and performance. Cost-benefit and cost-responsibility for investments will need to be considered.

A number of communities in this sub-region are also in the process of developing community-energy plans (“CEPs”). While regional planning focuses on maintaining reliability of electricity supply, CEPs takes into consideration other energy uses, such as transportation, natural gas and electricity. CEPs also have different goals, including net zero energy, electrification, and reducing emissions. Since CEP and regional planning processes have different objectives and scope, greater coordination between community energy planning and regional planning processes is required to help provincial system and municipal planners develop a common understanding of growth and local developments and to identify opportunities to develop community-based energy solutions.

Recommended Actions

1. Monitor electricity demand growth closely to determine if and when an investment decision for the Dryden 115 kV sub-system is required

On an annual basis, the Working Group will review electricity demand growth in the West of Thunder Bay and the North of Dryden Sub-regions with the members of the Local Advisory Committees (“LACs”). This information will be used to determine if and when an investment decision for the Dryden 115 kV sub-system is required.

2. Ensure communities are informed of bulk and distribution planning activities in the West of Thunder Bay Sub-region

The Working Group will provide a status update at LAC meetings on bulk and distribution planning activities and associated projects.

3. Explore opportunities to further improve service reliability and power quality in consideration of cost-benefit and cost allocations

Communities and customers who are looking to further improve service reliability and performance may work with Hydro One Transmission and LDCs to develop transmission,

distribution and community energy solutions. The cost and benefit of improvements and how costs would be allocated will need to be considered.

4. Coordinate regional and community energy planning activities

Greater coordination between community energy planning and regional planning processes can inform dialogue on energy issues and can assist provincial system planners and local communities in developing a common understanding of the growth and local developments and in identifying opportunities to develop community-based energy solutions. Going forward, LAC meetings can be used as an opportunity to facilitate discussions on: (1) status of local growth and developments, (2) local planning priorities, (3) energy planning activities, (4) impact of supply interruptions, and (5) the potential, feasibility and challenges of implementing community-based energy solutions. Due to the unique energy planning challenges in northwestern Ontario, it would be helpful to identify initiatives to facilitate knowledge sharing and coordinate community energy planning activities in northern Ontario (e.g., a community energy planning webinar or workshop for communities in northern Ontario).

3. Development of the Integrated Regional Resource Plan

3.1 The Regional Planning Process

In Ontario, planning to meet the electricity needs of customers at a regional level is done through regional planning. Regional planning assesses the interrelated needs of a region—defined by common electricity supply infrastructure—over the near, medium, and long term and develops a plan to ensure cost-effective, reliable electricity supply. Regional plans consider the existing electricity infrastructure in an area, forecast growth and customer reliability, evaluate options for addressing needs, and recommend actions.

Regional planning has been conducted on an as needed basis in Ontario for many years. Most recently, the former Ontario Power Authority (“OPA”) carried out planning activities to address regional electricity supply needs. The OPA conducted joint regional planning studies with distributors, transmitters, the IESO and other stakeholders in regions where a need for coordinated regional planning had been identified.

In the fall of 2012, the Board convened a Planning Process Working Group (“PPWG”) to develop a more structured, transparent, and systematic regional planning process. This group was composed of industry stakeholders including electricity agencies, utilities, and stakeholders, and in May 2013, the PPWG released its report to the Board³ (“PPWG Report”), setting out the new regional planning process. Twenty-one electricity planning regions were identified in the PPWG Report, and a phased schedule for completion was outlined. The Board endorsed the PPWG Report and formalized the process timelines through changes to the Transmission System Code and Distribution System Code in August 2013, as well as through changes to the OPA’s licence in October 2013. The OPA’s licence changes required it to lead a number of aspects of regional planning. After the merger of the IESO and the OPA on January 1, 2015, the regional planning responsibilities identified in the OPA’s licence were transferred to the IESO.

The regional planning process begins with a Needs Screening performed by the transmitter, which determines whether there are needs requiring regional coordination. If regional planning is required, the IESO then conducts a Scoping Assessment to determine whether a comprehensive IRRP is required, which considers conservation, generation, transmission, and

³ http://www.ontarioenergyboard.ca/OEB/Documents/EB-2011-0043/PPWG_Regional_Planning_Report_to_the_Board_App.pdf

distribution solutions, or whether a more limited “wires” solution is the only option such that a transmission and distribution focused Regional Infrastructure Plan (“RIP”) can be undertaken instead. The Scoping Assessment assesses what type of planning is required for each region. There may also be regions where infrastructure investments do not require regional coordination and so can be planned directly by the distributor and transmitter outside of the regional planning process. At the conclusion of the Scoping Assessment, the IESO produces a report that includes the results of the Needs Screening process and a preliminary Terms of Reference. If an IRRP is the identified outcome, the IESO is required to complete the IRRP within 18 months. If an RIP is the identified outcome, the transmitter takes the lead and has six months to complete it. It should be noted that a RIP may be initiated after the Scoping Assessment or after the completion of all IRRPs within a planning region; the transmitter may also initiate and produce a RIP report for every region. Both RIPs and IRRPs are to be updated at least every five years. The draft Scoping Assessment Outcome Report is posted to the IESO’s website for a 2-week comment period prior to finalization.

The final IRRPs and RIPs are posted on the IESO’s and relevant transmitter’s websites, and may be referenced and submitted to the Board as supporting evidence in rate or “Leave to Construct” applications for specific infrastructure investments. These documents are also useful for municipalities, First Nations communities and Métis community councils for planning, conservation and energy management purposes, as information for individual large customers that may be involved in the region, and for other parties seeking an understanding of local electricity growth, CDM and infrastructure requirements. Regional planning is not the only type of electricity planning that is undertaken in Ontario. As shown in Figure 3-1, there are three levels of planning that are carried out for the electricity system in Ontario:

- Bulk system planning
- Regional system planning
- Distribution system planning

Planning at the bulk system level typically considers the 230 kV and 500 kV network and examines province-wide system issues. Bulk system planning considers not only the major transmission facilities or “wires”, but it also assesses the resources needed to adequately supply the province. This type of planning is typically carried out by the IESO pursuant to government policy. Distribution planning, which is carried out by LDCs, considers specific investments in an LDC’s territory at distribution level voltages.

Regional planning can overlap with bulk system planning. For example, overlaps can occur at interface points where there may be regional resource options to address a bulk system issue. Similarly, regional planning can overlap with the distribution planning of LDCs. For example, overlaps can occur when a distribution solution addresses the needs of the broader local area or region. Therefore, it is important for regional planning to be coordinated with both bulk and distribution system planning as it is the link between all levels of planning.

Figure 3-1: Levels of Electricity System Planning

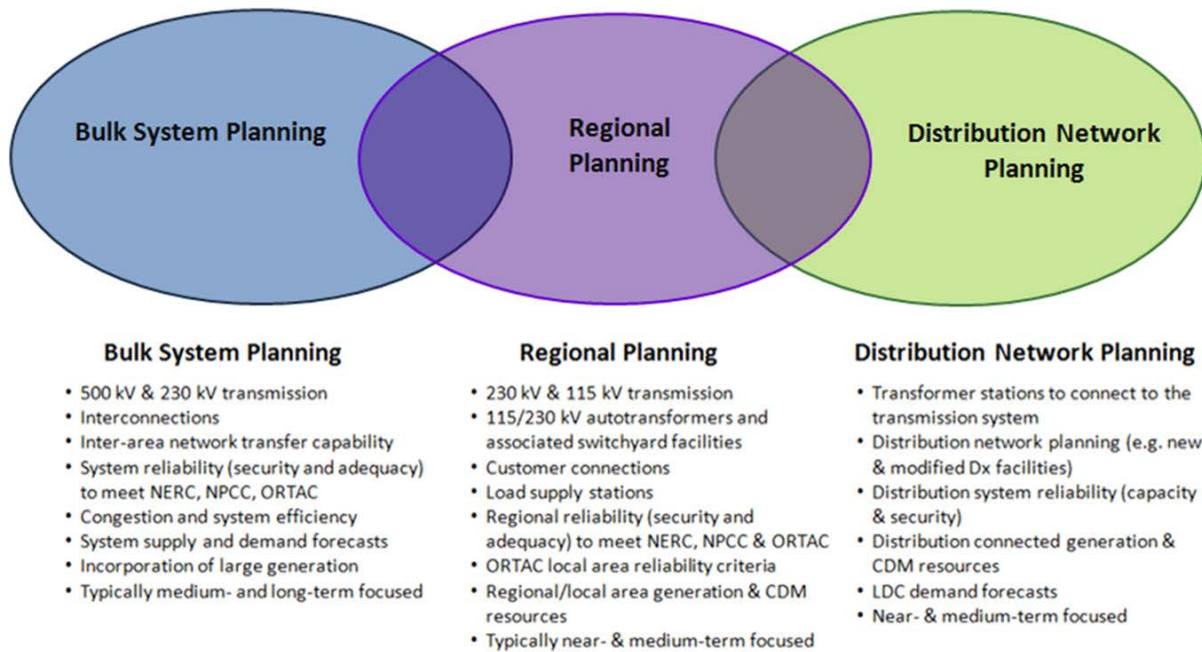

By recognizing the linkages with bulk and distribution system planning, and coordinating multiple needs identified within a region over the long term, the regional planning process provides a comprehensive assessment of a region’s electricity needs. Regional planning aligns near- and long-term solutions and puts specific investments and recommendations coming out of the plan in perspective. Furthermore, regional planning optimizes ratepayer interests by avoiding piecemeal planning and asset duplication, and allows Ontario ratepayer interests to be represented along with the interests of LDC ratepayers, and individual large customers. IRRPs evaluate the multiple options that are available to meet the needs, including conservation, generation, and “wires” solutions. Regional plans also provide greater transparency through engagement in the planning process, and by making plans available to the public.

3.2 The IESO's Approach to Integrated Regional Resource Planning

IRRP's assess electricity system needs for a region over a 20-year period. The 20-year outlook anticipates long-term trends in a region, so that near-term actions are developed within the context of a longer-term vision. This enables coordination and consistency with the long-term plan, rather than simply reacting to immediate needs.

Planning in northwestern Ontario requires a unique approach. In southern Ontario, most of the forecast load growth is driven by growth in the LDC customer base. In northwestern Ontario the majority of the forecast load growth is driven by new or expanding large transmission-connected industrial customers, the majority of which are in the resource sector or are unique development projects. Therefore, when establishing the need for electricity enhancements and developing integrated alternatives, industrial customers generally drive the nature and magnitude of the electrical demand requirements.

The IRRP describes the Working Group's recommendations for system enhancements based on different scenarios. The Working Group also recommends staging options to mitigate reliability and cost risks related to demand forecast uncertainty associated with individual large customers. The recommendations of the IRRP seek to ensure flexibility is maintained such that changing long-term conditions may be accommodated.

In developing this IRRP, the Working Group followed a number of steps. These steps included: data gathering, including development of electricity demand forecasts; technical studies to determine electricity needs and the timing of these needs; the development of potential options; and, preparation of a recommended plan including actions for the near and longer term. Throughout this process, engagement was carried out with local municipalities, First Nation communities, Métis community councils and local stakeholders. These steps are illustrated in Figure 3-2 below.

Figure 3-2: Steps in the IRRP Process

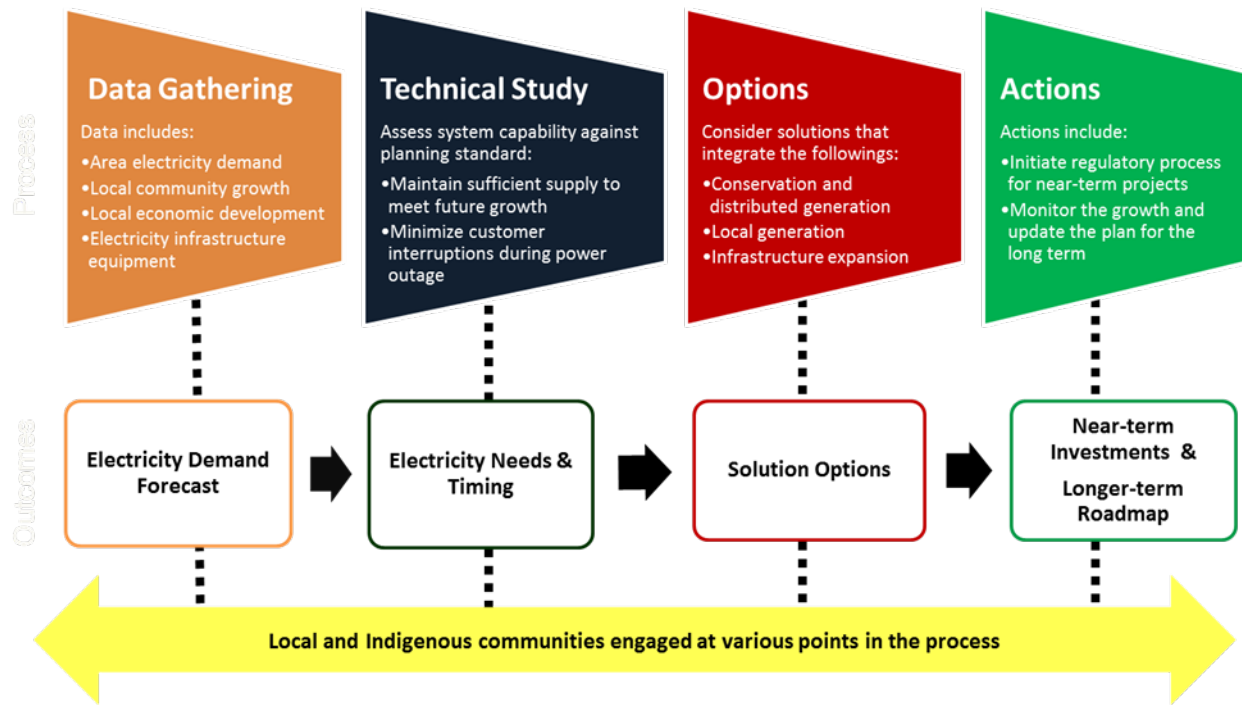

This IRRP documents the inputs, findings, and recommendations developed through the process described above, and provides recommended actions for the various entities responsible for plan implementation.

3.3 West of Thunder Bay Sub-region Working Group and IRRP Development

In 2014, the lead transmitter – Hydro One Transmission– initiated a Needs Screening process for the Northwest Ontario Region. The North of Dryden IRRP⁴ and Remote Community Connection Plan⁵ were already underway prior to the formalization of the regional planning process and were therefore not included within the scope of the Needs Screening process. The Northwest Ontario Region Needs Screening study team determined that the need for coordinated regional planning had already been established, and that a formal Needs Screening process was not required for the Northwest Ontario Region. A Scoping Assessment was then initiated to identify new planning sub-regions within the Northwest Ontario Region that were not already identified in previous planning studies.

⁴ <http://www.ieso.ca/Pages/Ontario's-Power-System/Regional-Planning/Northwest-Ontario/North-of-Dryden.aspx>

⁵ <http://www.ieso.ca/Pages/Ontario's-Power-System/Regional-Planning/Northwest-Ontario/Remote-Community-Connection-Plan.aspx>

On December 12, 2014, a draft Scoping Assessment Outcome Report (“Scoping Report”) was posted for public comment. The Scoping Report was finalized on January 28, 2015, and it incorporated feedback from community, stakeholder, and First Nation and Métis community meetings. The Scoping Report identified the West of Thunder Bay Sub-region as one of three new planning sub-regions for coordinated regional planning, as illustrated in Figure 3-3.

Figure 3-3: Northwest Ontario Region and Sub-regions



Subsequently, the Working Group was formed to carry out the IRRP for the West of Thunder Bay Sub-region.

For the purpose of regional planning, two LACs have been established for this sub-region: a General LAC and a First Nation LAC. The LACs were informed of the planning activities in the area and provided their input on the status of local growth and developments, local planning priorities, energy planning activities (e.g., community energy planning), local electricity concerns, and opportunities to implement community-based energy solutions. Greater detail regarding community and stakeholder engagement activities is provided in Section 9 of this report.

4. Background and Study Scope

The sub-region and the scope of the IRRP are described in Section 4.1. Section 4.2 details the electricity system supplying the West of Thunder Bay Sub-region.

4.1 West of Thunder Bay - Study Scope

The West of Thunder Bay IRRP assesses the reliability of the regional electricity system supplying the West of Thunder Bay Sub-region and identifies integrated solutions for the 20-year period from 2015 to 2034.

The West of Thunder Bay Sub-region is defined as the area bordered to the south and west by the United States and Manitoba borders; it extends north to include Kenora, Dryden and Sioux Lookout, and east as far as (but not including) the City of Thunder Bay; the study area does not include the area north of Dryden⁶. The approximate geographical boundaries of the sub-region are shown in Figure 4-1.

Figure 4-1: Geographical Boundaries of the West of Thunder Sub-region

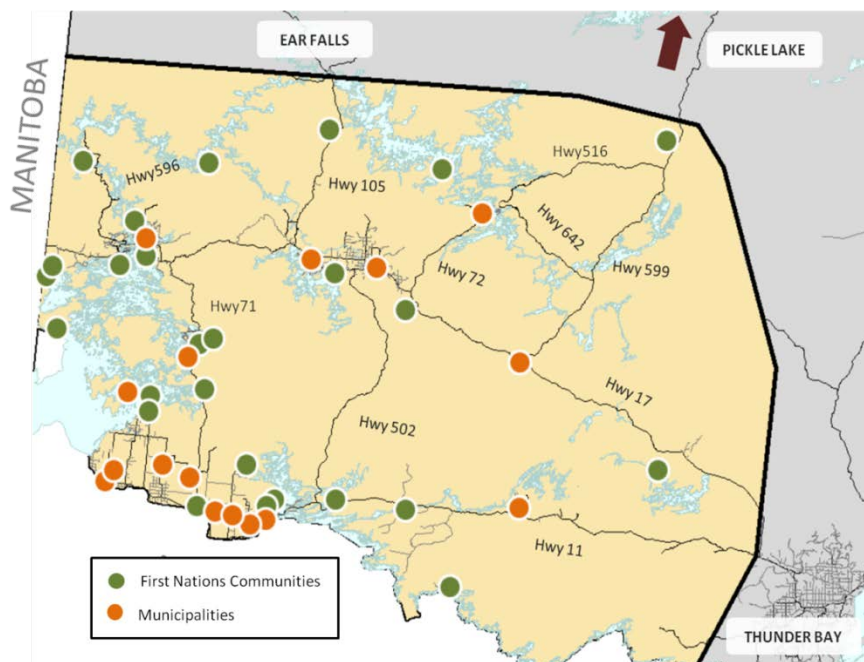

⁶ The North of Dryden IRRP published in 2015 addresses the reliability of the electricity system supplying the North of Dryden sub-region (see http://www.ieso.ca/Documents/Regional-Planning/Northwest_Ontario/North_of_Dryden/North-Dryden-Report-2015-01-27.pdf)

The West of Thunder Bay Sub-region includes the following First Nations:

- Anishinabe of Wauzhushk Onigum
- Anishinaabeg of Naongashiing
- Big Grassy
- Couchiching
- Eagle Lake
- Grassy Narrows
- Iskatewizaagegan #39
- Lac Des Mille Lacs
- Lac La Croix
- Lac Seul
- Mitaanjigamiing
- Naicatchewenin
- Naotkamegwanning
- Nigigoonsiminikaaning
- Northwest Angle #33
- Northwest Angle #37
- Obashkaandagaang
- Ochiichagwe' Babigo' Ining
- Ojibway Nation of Saugeen
- Ojibways of Onigaming
- Rainy River
- Seine River
- Shoal Lake #40
- Wabaseemoong
- Wabauskang
- Wabigoon Lake Ojibway

The sub-region also includes the following municipalities:

- Township of Alberton
- Town of Atikokan
- Township of Chapple
- Township of Dawson
- Township of Emo
- Town of Fort Frances
- Township of Lake of the Woods
- Township of La Vallee
- Township of Morley

- Town of Rainy River
- City of Dryden
- City of Kenora
- Municipality of Machin
- Municipality of Sioux Lookout
- Township of Ignace
- Township of Sioux Narrows-Nestor Falls

In addition, there are a number of unorganized areas⁷ in the Rainy River and Kenora Districts.

This IRRP addresses the reliability of the 115 kV regional transmission systems. The reliability of the 230 kV bulk transmission system and distribution systems supplying the area is beyond the scope of the regional planning process and this IRRP. 230 kV Bulk system and distribution system related concerns are for context referenced in Section 6.3, but they will be formally addressed through the bulk system and distribution systems planning processes.

It is important to note that connection assessment of generation resources for procurement programs, such as the Feed-in-Tariff and, the Large Renewable Procurement, are beyond the scope of this IRRP. Generation projects participating in procurement programs will be assessed according the rules and specifications of the procurement programs.

4.2 West of Thunder Bay Electricity System

The West of Thunder Bay electricity system consists of local generation resources, 230 kV bulk transmission, 115 kV regional transmission and low voltage distribution networks. Local generation resources provide important sources of electricity supply to the communities and customers in this sub-region. However, under certain system conditions (e.g., generation outages or if electricity demand exceeds the capability of local generation), local generation sources would need to be supplemented with power delivered to the sub-region from the rest of the province through the 230 kV bulk transmission system. From the 230 kV bulk transmission system, power is then delivered to various communities and customers through the regional 115 kV and low-voltage distribution networks. The following sub-sections discuss these components in more details.

⁷ Unorganized areas are parts of the province where there is no municipal level of government. Services in these unorganized districts are typically administered by local service boards.

4.2.1 Local Generation Resources

There are three types of generation resources totaling to about 491 Megawatts (“MW”) in the West of Thunder Bay Sub-region: hydroelectric (water), biomass and solar, as shown in Figure 4-2.

Figure 4-2: Installed Capacity of Generation Resources in the West of Thunder Bay Sub-region (MW)

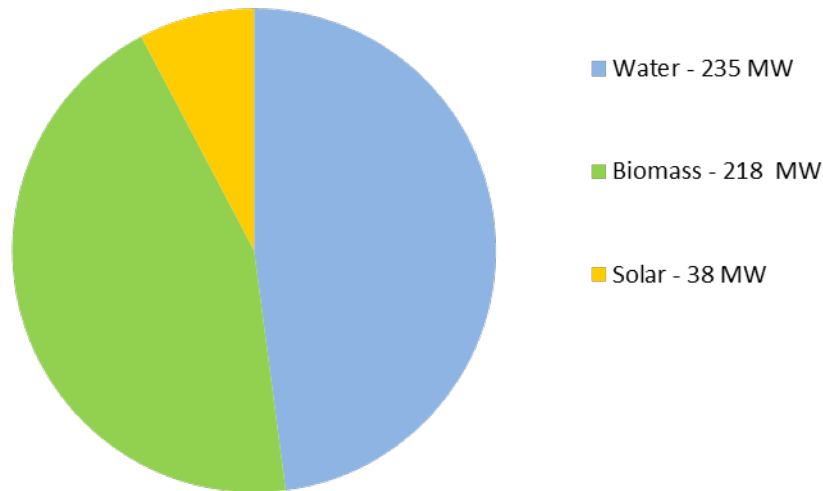

In Ontario, the electricity system is designed to meet regional coincident peak demand – i.e., the 1-hour period each year when total demand for electricity in the region (or sub-region) is the highest. While hydroelectric, biomass and solar resources are a potential source of energy, only a certain amount of power can be relied upon at the time of peak due to the variable nature of these resources. In the West of Thunder Bay Sub-region, electricity demand typically peaks during the evening in the winter season. For the purposes of infrastructure planning, the installed capacity of distributed and variable generation is adjusted to reflect the reliable power output at the time of the local winter peak.

Below is a description of local generation resources in the West of Thunder Bay Sub-region.

- **Hydroelectric (Water):** Hydroelectric resources account for almost 50 percent of the installed capacity in the sub-region (about 235 MW). While there are a number of small scale hydroelectric generators, the major facilities, Caribou and Whitedog Generating Stations, are situated in the Kenora area. All hydroelectric resources in this sub-region are run-of-river facilities and have limited storage capability. As such, hydroelectric

output is highly variable and is dependent on water conditions. During drought and low water conditions, power output is reduced to less than a third of the installed capacity. In some cases, high waters and flooding conditions may also reduce the power output from these facilities.

- **Biomass:** In 2014, the coal-fired generation facility at Atikokan was converted to burn biomass (wood pellets). This facility currently is contracted with the IESO until 2024 and has the capacity to generate up to 200 MW. Based on the current contract terms, the facility purchases up to 90,000 tonnes of biomass fuel annually. The forecast fuel availability will limit energy production to 140 GWh per year and may limit the amount of hours it can operate at the maximum capacity. For the purpose of this IRRP, it is assumed that Atikokan facility may operate as a merchant facility upon expiration of the contract. There are currently two merchant biomass generation facilities near Dryden and Fort Frances.
- **Solar:** A 25 MW transmission-connected solar facility is in operation in the Rainy River area. Many communities have also installed small-scale, distribution-connected solar facilities. Today, solar resources account for a small portion of the local, installed capacity. Solar is an intermittent resource and power output can vary depending on factors such as cloud cover, location, time of day, and season. As the local peak typically occurs during the evening in the winter, solar resources are not expected to contribute to the reduction of the local peak demand.

4.2.2 Transmission System

The transmission system in the sub-region consists of 230 kV and 115 kV lines and stations, as shown in Figure 4-3.

Figure 4-3: West of Thunder Bay Sub-region – Transmission System

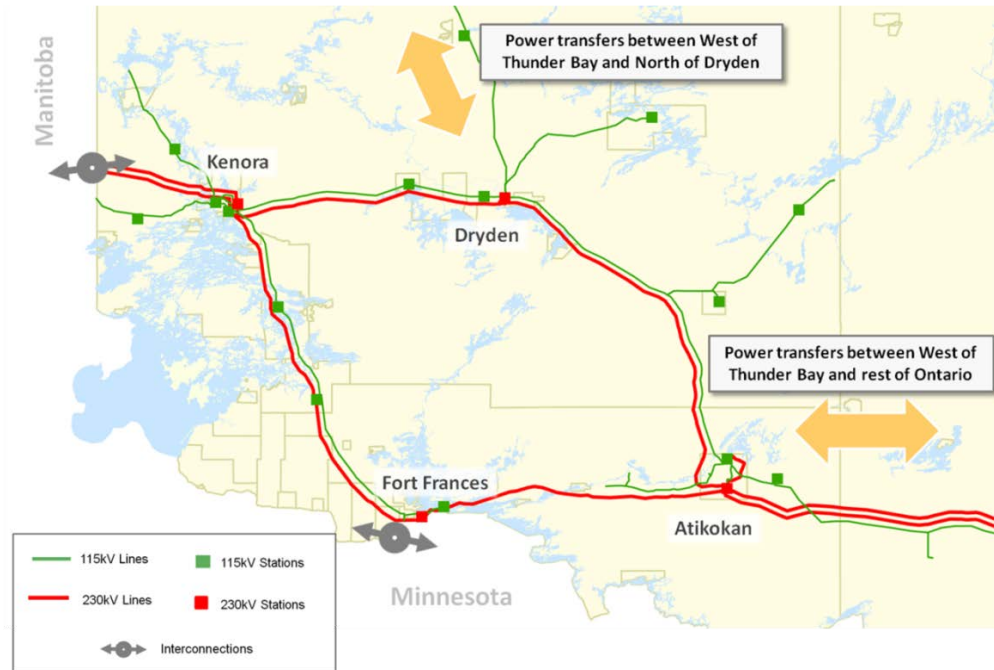

The West of Thunder Bay transmission system is interconnected with Manitoba at Kenora and with Minnesota at Fort Frances. The interconnections with Manitoba and Minnesota handle transfers scheduled on an economic basis to address provincial needs and are not relied upon for maintaining local reliability. As the electricity system in this area is a source of supply to the North of Dryden Sub-region, its electricity requirements are affected by the potential growth in the area north of Dryden.

The West of Thunder Bay transmission system can be broken down into two components: 230 kV bulk transmission system and 115 kV regional sub-systems. These components are described in more detail below.

230 kV Bulk Transmission System

The bulk transmission system consists of a double circuit 230 kV line and a single-circuit 115 kV line between Thunder Bay and Atikokan. These lines bring power into the West of Thunder Bay Sub-region to supplement local generation resources. To the west of Atikokan, a diamond-

shaped, 230 kV bulk transmission network connects to Fort Frances, Dryden and Kenora. There are step-down stations that connect to local 115 kV networks at Kenora, Fort Frances, Dryden and Atikokan. Issues related to the bulk system are for context discussed in this IRRP, but these issues will be addressed as part of bulk transmission system planning.

Regional 115 kV Sub-systems

Figure 4-4: Regional 115 kV Sub-systems in the West of Thunder Bay Sub-region

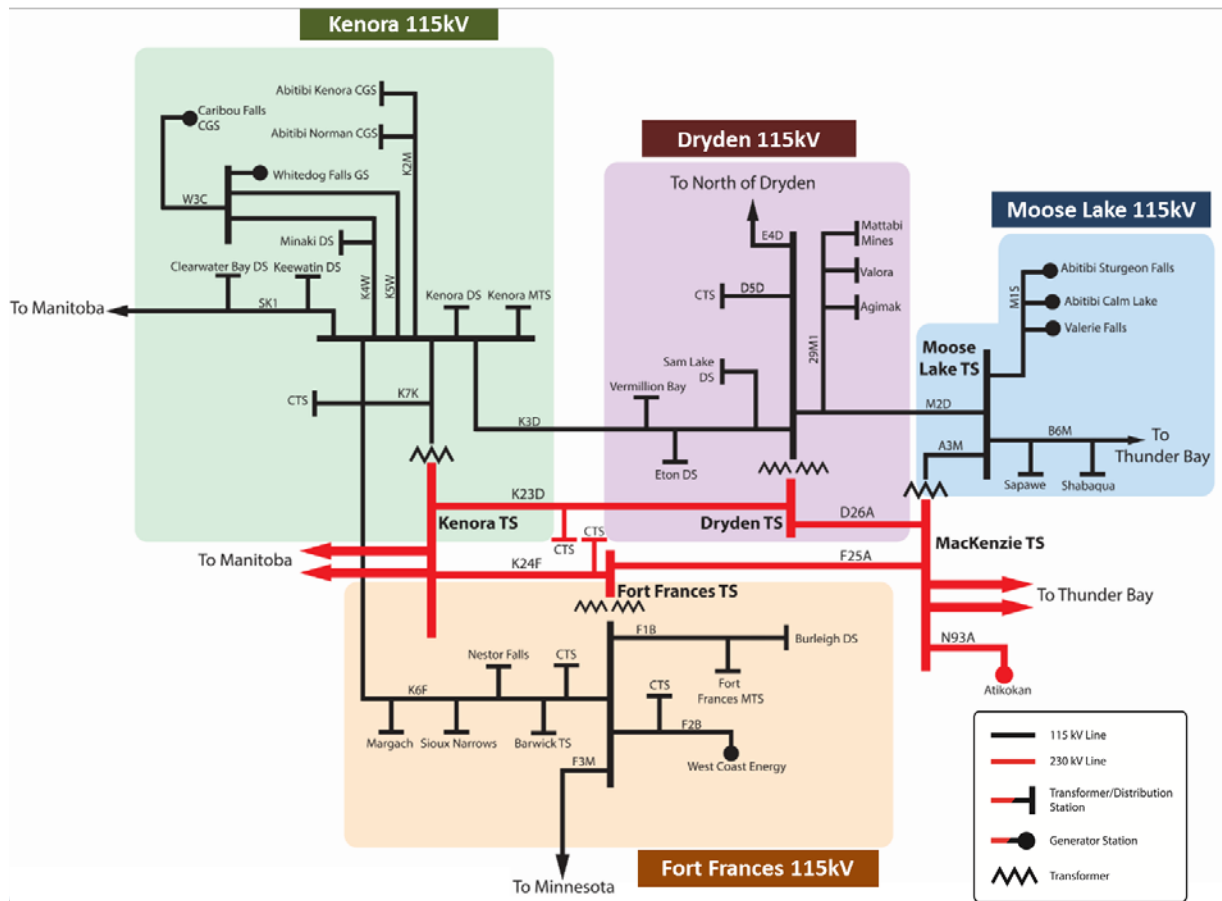

The regional 115 kV sub-systems (as shown in Figure 4-4) enable power to be delivered to communities and customers in the West of Thunder Bay Sub-region. There are four 115 kV sub-systems in the sub-region:

- **Dryden 115 kV sub-system:** Today, this sub-system provides up to 65 MW of power to customers and communities in the Dryden and surrounding areas and supplies up to 68 MW to the North of Dryden Sub-region through the 115 kV line from Dryden to Ear Falls. The two 230 kV/115 kV autotransformers at Dryden are the primary sources

of supply into this sub-system. This sub-system also includes 115 kV connection lines to the Kenora and Atikokan areas.

- **Kenora 115 kV sub-system:** The Kenora and surrounding areas are supplied by this 115 kV sub-system. Today, this sub-system has a winter peak demand of about 60 MW. In addition to the 230 kV/115 kV autotransformer at Kenora, this sub-system relies on local hydroelectric facilities, including Norman, Caribou and Whitedog, as the main sources of electricity supply. This sub-system also has 115 kV connections to Fort Frances, Dryden and Manitoba.
- **Fort Frances 115 kV sub-system:** During the winter season, this sub-system provides up to 75 MW of supply to customers and communities in the Fort Frances and surrounding areas. This sub-system is supplied by local hydroelectric facilities and the two 230 kV/115 kV autotransformers at Fort Frances and has 115 kV connections to Kenora and Minnesota.
- **Moose Lake 115 kV sub-system:** Today, this sub-system provides up to 13 MW of electricity supply to customers and communities in the Atikokan and surrounding areas. While this sub-system is primarily supplied by a 230 kV/115 kV autotransformer near Atikokan, the 115 kV connections to Dryden and Thunder Bay and the small hydroelectric facilities also provide electricity supply.

The focus of this IRRP will be on the reliability of the 115 kV regional sub-systems in the West of Thunder Bay Sub-region.

4.2.3 Distribution System

From the regional 115 kV sub-systems, power is delivered through transformer stations to the low-voltage distribution systems. There are 36 customer and utility-owned transformer stations that service the various communities and industrial customers in this sub-region. Given the large geographic and sparsely populated areas, many communities and customers in the West of Thunder Bay Sub-region are supplied by long distribution lines and a single source of supply.

The low-voltage distribution system is managed and operated by five LDCs: Atikokan Hydro, Fort Frances Power Corporation, Kenora Hydro, Sioux Lookout Hydro, and Hydro One Networks (Distribution), as shown in Figure 4-5.

Figure 4-5: Local Distribution Companies (LDCs) Service Area

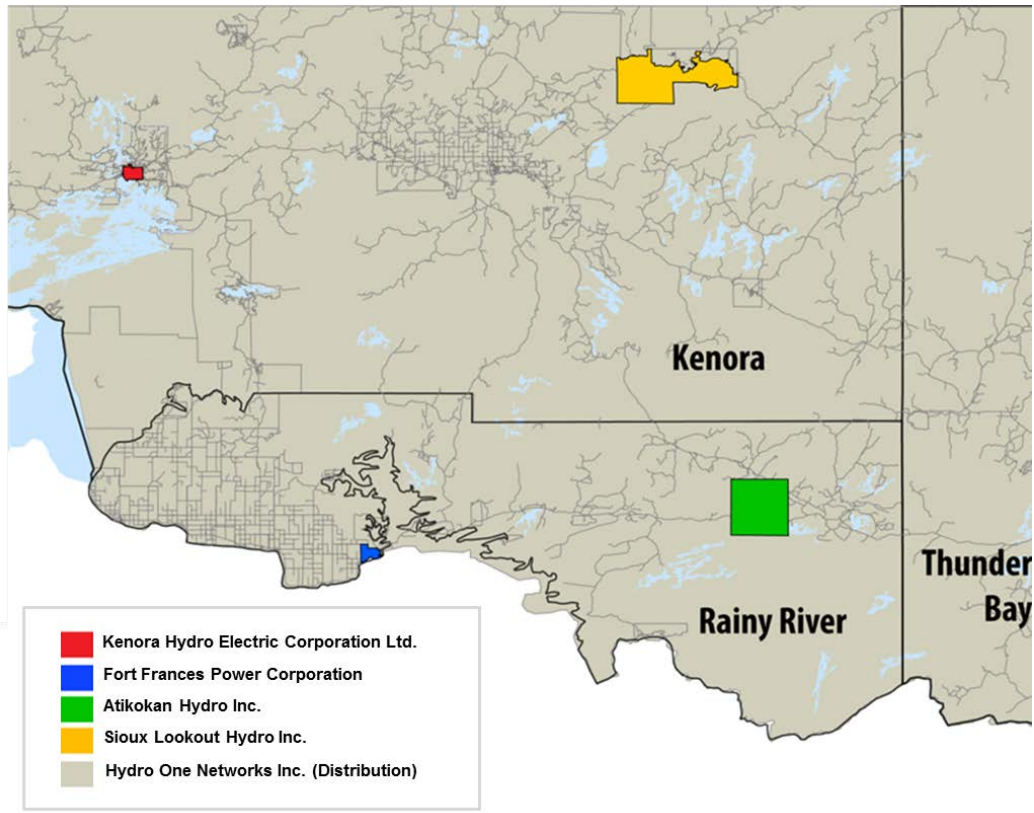

Distribution system planning is beyond the scope of the regional planning process. Issues related to the distribution system may for context be discussed in this IRRP, but they will be addressed as part of the distribution planning process led by the LDCs.

The details regarding the characteristics of the LDC service areas can be found in Appendix A.

5. Demand Forecast

Regional electricity systems in Ontario are designed to meet regional coincident peak demand – the one-hour period each year when total regional demand for electricity is the highest.

This section describes the development of the regional electricity demand forecast for the West of Thunder Bay Sub-region. Section 5.1 describes electricity demand trends in the sub-region from 2004 to 2014. Section 5.2 provides an overview of the demand forecast methodology used in this study, and Section 5.3 summarizes the various demand scenarios.

5.1 Historical Electricity Demand 2004-2014

The West of Thunder Bay Sub-region's peak electrical demand typically occurs during the evening in the winter. This is driven by a large electrical heating demand in the residential sector as access to natural gas in the area is limited.

In addition to the heating requirements from the residential sector, there are a number of large industrial customers in the pulp and paper and forestry sectors. These industrial customers consume a large amount of energy on a continuous basis; however, they are sensitive to changing economic conditions (e.g., commodity prices, changes in economic growth) which can have material impacts on annual energy demand. As shown in Figure 5-1, historical winter peak demand in the sub-region has decreased from a high of 335 MW in 2005 to a low of 210 MW in 2014. This decline in electrical load is primarily due to the closure of numerous large industrial customers in the pulp and paper sectors.

Figure 5-1: West of Thunder Bay Sub-region Historical Peak Demand (2004-2014)

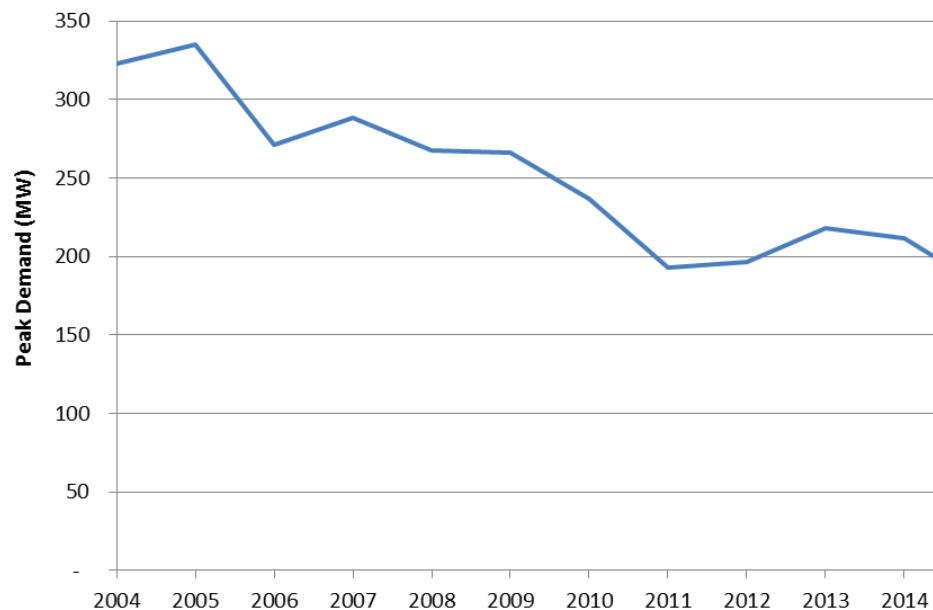

5.2 Methodology for Establishing Planning Forecast Scenarios

Demand forecast scenarios were developed to assess reliability of the West of Thunder Bay electricity system over the planning period. For the purpose of regional planning, these demand scenarios take into consideration a number of components:

- Gross winter demand forecast scenarios for distribution-connected and transmission-connected customers,
- Estimated peak demand savings from meeting provincial energy conservation targets, and
- Expected peak capacity contribution from DG.

Gross demand forecast scenarios were developed based on the expected peak demand projections for distribution-connected and transmission-connected customers in the West of Thunder Bay Sub-region. For each scenario, these growth projections are modified to reflect the estimated peak demand savings from meeting provincial energy conservation targets and from existing and contracted DG.

Using a planning forecast that is net of provincial conservation targets is consistent with the province's Conservation First policy. However, this assumes that the targets will be met and that the targets, which are energy-based, will produce the expected local peak demand impacts.

An important aspect of plan implementation will be monitoring the actual peak demand impacts of conservation programs delivered by the local LDCs and, as necessary, adapting the plan accordingly.

The methodology and assumptions used for the development of the demand forecast scenarios are described in detail in Appendix A.

5.3 Development of Planning Forecast

5.3.1 Gross Demand Forecast Scenarios

The gross demand forecast is based on the gross electricity requirements for distribution-connected customers and transmission-connected customers in the sub-region.

Distribution-Connected Customers

The gross demand forecast for distribution-connected customers is provided by the five LDCs in the West of Thunder Bay Sub-region. Overall, the growth in electricity demand forecast from distribution-connected customers is expected to remain relatively modest. Most of the growth is attributed to requirements from small industrial customers, such as biomass pellet plants and saw mills, community development associated with the new gold mine near Rainy River and population growth in First Nations communities. Descriptions of the LDCs' forecast assumptions and methodology can be found in Appendix A.

Transmission-Connected Customers

The gross demand forecast for transmission-connected customers is developed based on information gathered from transmission-connected industrial customers. The IESO and Hydro One Transmission regularly communicate with existing and potential transmission-connected industrial customers to understand their electricity demand requirements and their operation and development status.

Over the planning period, the demand growth in the West of Thunder Bay Sub-region will be primarily driven by large, transmission-connected industrial customers, including gold mines near Rainy River and Dryden, and the proposed gas to oil pipeline development. New transmission-connected industrial customers could potentially add up to 300 MW of incremental electricity demand by 2034. As discussed, industrial customers are particularly sensitive to the changes in economic conditions. The timing, location and scale of industrial

developments is uncertain and will depend on a number of external factors, such as the commodity price of the resource, the economic viability of the industrial project, and the ability to secure capital. Often these factors can lead to material increases or decreases in annual demand. For example, due to declining gold prices, the development of a prospective, large gold mine near Atikokan, with peak demand requirements of up to 125 MW, was suspended in 2014. Other developments, by contrast, are proceeding. For example, a new gold mine near Rainy River, with a peak demand requirement of up to 60 MW, is currently under construction and should be in operation by 2017.

Since these changes are often difficult to anticipate, a scenario based approach was used to ensure the sub-region's electricity system is able to adequately supply electricity to industries and communities under various assumptions and conditions. Three scenarios (Reference, High and Low) are described in Section 5.3.4.

The specific forecasting methodology and assumptions for the gross demand forecast scenarios can be found in Appendix A.

5.3.2 Expected Peak Demand Savings from Provincial Conservation Targets

Conservation is the first resource considered in planning, approval and procurement processes. It plays a key role in maximizing the utilization of existing infrastructure and maintaining reliable supply by keeping demand within equipment capability. Conservation is achieved through a mix of program-related activities, rate structures, and mandated efficiencies from building codes and equipment standards. The conservation savings forecast for the sub-region have been applied to the gross peak demand forecast, along with DG resources (described in Section 5.2), to determine the planning forecast for the sub-region.

In December 2013 the Ministry of Energy released a revised Long-Term Energy Plan ("LTEP") that outlined a provincial conservation target of 30 terawatt-hours ("TWh") of energy savings by 2032. A portion of this province-wide energy conservation target was allocated to the West of Thunder Bay Sub-region, and, as further described below, it was further converted to an estimated peak demand reduction for the sub-region. To estimate the impact of the conservation savings in the area, the forecast provincial savings were divided into three main categories, as shown in Figure 5-2:

Figure 5-2: Categories of Conservation Savings

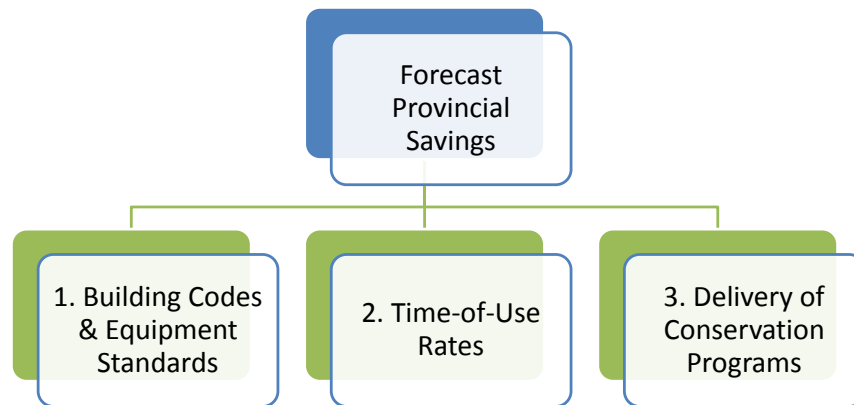

1. *Savings due to Building Codes & Equipment Standards*
2. *Savings due to Time-of-Use Rate structures*
3. *Savings due to the delivery of Conservation Programs*

The 2013 LTEP committed to establishing a new 6-year Conservation First Framework (“CFF”) beginning in January 2015 to enable the achievement of all cost-effective conservation. In the near term, Ontario’s LDCs have an aggregate energy reduction target of 7 TWh, as well as individual LDC specific targets. These targets are to be achieved between 2015 and the end of 2020 through LDC conservation programs enabled by the CFF. In 2015, each LDC submitted a CDM plan to the IESO describing how the targets will be achieved. LDCs are also required to provide updates to their CDM plans.

As part of the Conservation First policy, the provincial government has adopted a broad definition of conservation that includes various types of customer action and behind-the-meter generation. This means that conservation includes any programs or mechanisms that reduce the amount of energy consumed from the provincial electricity grid. Conservation initiatives, including behind-the-meter generation projects and on-site generation, are expected to reduce customers’ reliance on the provincial electricity grid and contribute to peak demand savings in the sub-region. Conservation initiatives, including behind-the-meter generation projects and on-site generation, are expected to reduce customers’ reliance on the provincial electricity grid and contribute to peak demand savings in the sub-region.

For the purpose of this IRRP, the allocation of the 7 TWh of provincial energy savings target to the West of Thunder Bay Sub-region is estimated to offset approximately 14 MW of the forecast peak demand between 2015 and 2034. Savings from potential future demand response (“DR”) resources are not included in the forecast. Instead, the development of locally targeted DR projects may be considered as potential solutions to address future needs.

The estimated annual peak demand savings from the provincial energy conservation targets in the West of Thunder Bay Sub-region are summarized in Appendix A.

5.3.3 Expected Peak Demand Contribution of Existing and Contracted Distributed Generation

As of 2015, about 38 MW of DG was contracted in the West of Thunder Bay Sub-region. For the purpose of developing the planning forecast, contracted DG is expected to reduce the regional peak demand by about 1.5 MW over the next 20 years. Future DG uptake was, as noted, not included in the planning forecast and is instead considered as an option for meeting identified needs.

The expected annual peak demand contribution of contracted DG in the West of Thunder Bay Sub-region can be found in Appendix A.

5.3.4 Planning Forecast

A scenario-based approach was used to account for the uncertainty in the demand forecast. Figure 5-3 shows planning demand scenarios for the West of Thunder Bay Sub-Region (2015 to 2034, using a base year of 2014). The scenarios represent plausible outcomes that must be considered in planning for the electricity needs of the sub-region. The demand forecast scenarios shown below take into consideration the gross demand forecast scenarios, estimated peak demand savings from provincial energy conservation targets, and existing and contracted DG.

Figure 5-3: Planning Forecast Scenarios ⁸

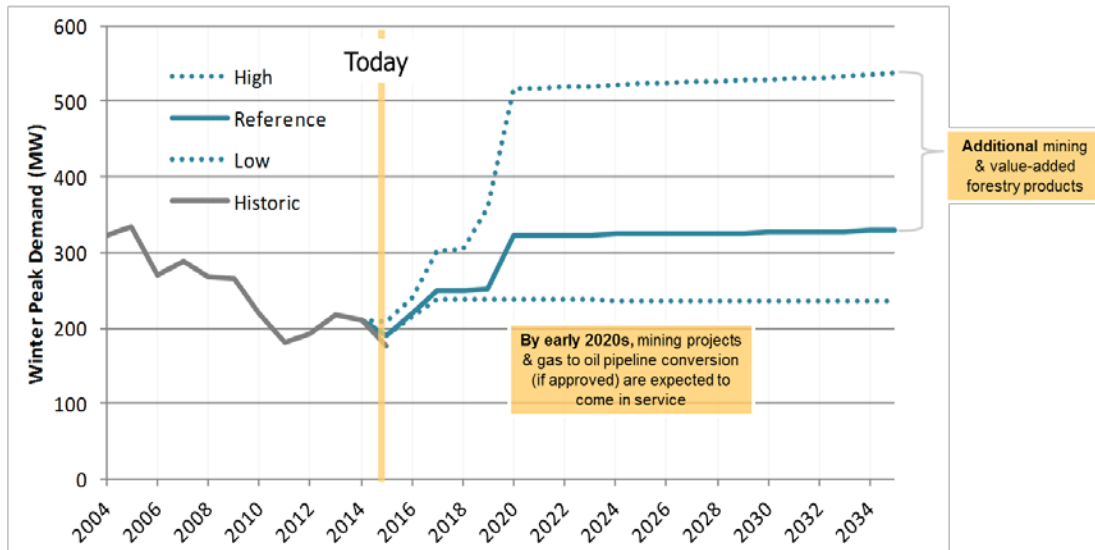

Reference scenario

Under the Reference scenario, the winter peak electricity demand in the West of Thunder Bay Sub-region is expected to increase to 330 MW over the planning period. As shown in Figure 5-3, by the mid-2020s, the peak demand will be similar to 2004 levels. The growth includes two transmission-connected mining developments near the Dryden and Rainy River areas. Together, these developments could increase regional electricity demand by up to 70 MW.

For the purpose of regional planning, it is also assumed that the proposed gas to oil pipeline development will be approved and that four oil pumping stations will be supplied from the West of Thunder Bay transmission system under the Reference scenario. The pumping stations would each require approximately 15 to 18 MW of electricity supply by 2020.

High scenario

In addition to the growth identified in the Reference scenario, the High scenario assumes more transmission-connected mining developments and the recovery of the local pulp and paper industry, for example the restart of the mill in the Fort Frances area. The electricity demand from the proposed gas to oil pipeline development is expected to increase as a total of six oil pumping stations will be supplied from the West of Thunder Bay transmission system under

⁸ West of Thunder Bay Sub-region demand forecast does not include growth in the North of Dryden Sub-region. The demand forecast for the North of Dryden Sub-region is discussed in Section 5.4.

this scenario. With these additional developments, the total demand could grow to 540 MW by the end of the study period.

Low scenario

Aside from the above-mentioned mining development in the River Rainy area, no additional mining development is expected to materialize under the Low scenario. It is assumed that the proposed gas to oil pipeline development will not proceed. This scenario results in a relatively flat electricity demand growth over the planning period.

Further details related to the demand forecast scenarios can be found in Appendix A.

5.4 Potential Growth in the North of Dryden Sub-region

The West of Thunder Bay electricity system is a major source of supply to the North of Dryden Sub-region, capable of transferring up to 85 MW via through the 115 kV line from Dryden to Ear Falls. In 2015, the winter peak demand in the North of Dryden area was about 68 MW.

Based on the North of Dryden IRRP published in 2015⁹, up to 170 MW of additional demand growth could materialize in the North of Dryden Sub-region and would require supply from the West of Thunder Bay 230 kV bulk transmission system. Depending on the location, magnitude and timing of these potential developments in the North of Dryden Sub-region, this could have an impact on the 115 kV Dryden regional sub-system.

The North of Dryden IRRP recommends building a new 230 kV line to Pickle Lake to support the potential developments in the North of Dryden Sub-region including connection of 21 remote First Nation communities. With the new 230 kV line to Pickle Lake, up to 120 MW of incremental demand from new mining developments and remote communities north and northeast of Pickle Lake would be supplied directly from the 230 kV West of Thunder Bay bulk transmission system. The remaining growth in the Red Lake and Ear Falls area (up to 50 MW of incremental demand), which includes the remote communities north of Red Lake, would be supplied directly from the Dryden 115 kV sub-system. To ensure that the West of Thunder Bay electricity system has sufficient capacity to serve growth in the West of Thunder Bay and North of Dryden Sub-regions, the potential growth and development in the area north of Dryden is taken in to consideration in the development of this IRRP.

⁹ http://www.ieso.ca/Documents/Regional-Planning/Northwest_Ontario/North_of_Dryden/North-Dryden-Report-2015-01-27.pdf

6. Needs

This section outlines the needs assessment methodology and identifies regional electricity supply and reliability needs over the 20-year planning period. In addition, other electricity needs and considerations at the bulk, distribution and community levels are also discussed in this section.

6.1 Needs Assessment Methodology

The IESO's ORTAC,¹⁰ the provincial standard for assessing the reliability of the transmission system, was applied to assess supply capacity and reliability needs. ORTAC includes criteria related to the assessment of the bulk transmission system, as well as the assessment of local or regional reliability requirements (see Appendix B for more details).

Through the application of these criteria, three broad categories of needs can be identified:

- **Transformer Station Capacity** is the electricity system's ability to deliver power to the local distribution network through the regional transformer stations. This is limited by the load meeting capability ("LMC") of the step-down transformer stations in the local area, which is the maximum demand that can be supplied from the transformer stations based on their combined transformer station ratings.
- **Supply Capacity** is the electricity system's ability to provide continuous supply to a local area. This is limited by the LMC of the transmission line or sub-system, which is the maximum demand that can be supplied on a transmission line or sub-system under applicable transmission and generation outage scenarios as prescribed by ORTAC; it is determined through power system simulations analysis (See Appendix B for more details). Supply capacity needs are identified when peak demand on a transmission line or sub-system exceeds its LMC.
- **Load Security and Restoration** is the electricity system's ability to minimize the impacts of potential supply interruptions to customers in the event of a major transmission outage, such as an outage on a double-circuit tower line resulting in the loss of both circuits. Load security describes the amount of load susceptible to supply interruptions in the event of a major transmission outage. Load restoration describes the electricity system's ability to restore power to those affected by a major transmission outage within

¹⁰ http://www.ieso.ca/imoweb/pubs/marketadmin/imo_req_0041_transmissionassessmentcriteria.pdf

reasonable timeframes. The specific load security and restoration requirements prescribed by ORTAC are described in Appendix B.

In addition, the needs assessment may also identify needs related to transmission service reliability performance, equipment end-of-life and planned sustainment activities. Service reliability performance describes the frequency and probability of major outages on an electricity system, which can be affected by various factors such as exposure to elements, age and maintenance of equipment, and length and configuration of the transmission or distribution networks. Equipment reaching the end of its life and planned sustainment activities may have an impact on the needs assessment and options development. Transmission assets reaching end-of-life are typically replaced with assets of equivalent capacity and specification. The need to replace aging transmission assets may present opportunities to better align investments with evolving power system priorities. This may involve up-sizing equipment in areas with capacity needs, or downsizing or even removing equipment that is no longer considered useful. Such instances may also present opportunities to enhance or reconfigure assets for infrastructure hardening to improve system resilience.

6.2 Regional Electricity Reliability Needs

For the purpose of regional planning, this IRRP focuses on identifying and addressing needs on the regional 115 kV sub-systems, as defined in Section 4.2.2. It is important to note that there may be a potential need for additional supply on the West of Thunder Bay 230 kV bulk system. This bulk system need is not within the scope of this IRRP, but for contextual reasons is discussed in Section 6.3.1.

Results from the needs assessment show all the regional 115 kV sub-systems are adequate over the planning period under Reference and Low scenarios. Under the High scenario, strong growth in the Dryden and North of Dryden Sub-region may exceed the Dryden 115 kV sub-system capacity over the planning period. End-of-life replacements, transmission service reliability and transformer station capacity needs were also identified in the West of Thunder Bay Sub-region. The following section describes these needs in more detail.

6.2.1 Potential Supply Capacity Need on the Dryden 115 kV Sub-system

The Dryden 115 kV sub-system can provide up to 240 MW of continuous supply to the Dryden area and North of Dryden Sub-region (Dryden 115 kV System LMC = 240 MW). Today, the Dryden 115 kV sub-system supplies 130 MW to the Dryden area and North of Dryden Sub-

region. Under the Reference scenario, electricity demand supplied by the Dryden 115 kV sub-system is expected to grow to about 240 MW by 2034. There will be sufficient capacity on the existing system to support this growth over the planning period.

Under the High scenario, however, the electricity demand on Dryden 115 kV sub-system can potentially increase to about 290 MW. The existing Dryden 115 kV sub-system therefore does not meet the ORTAC supply capacity under this particular scenario. If the forecast demand growth materializes under the High scenario, 50 MW of additional supply capacity may be required on the Dryden 115 kV sub-system in the mid-2020s. Given that the timing, magnitude and location associated with potential developments in the Dryden area are uncertain, it is important to monitor these potential developments before proceeding with an investment decision. Section 7.1 will provide a high-level discussion of potential options to address these concerns under the High scenario.

6.2.2 Transformer Station Capacity Needs in the Kenora area

The transformer station supplying the City of Kenora and surrounding areas (“Kenora MTS”) can supply up to 25 MW at the time of peak. Today, this transformer station currently supplies up to 20 MW. There is therefore about 5 MW of supply margin remaining on the transformer station. Since the residential and commercial growth in the Kenora area is forecast to be modest over the planning period, the remaining margin will be adequate to support commercial and residential developments in the area.

Recently, a large industrial customer in the Kenora area that has historically been supplied from a local dam is looking to Kenora MTS for alternative supply. Depending on the needs of the industrial customer, the requirement for additional transformer station capacity may be triggered in Kenora over the next few years. Potential developments at the former Abitibi mill site may also require additional transformer station capacity in the Kenora area. However, the timing and magnitude of these developments are uncertain at this time. Kenora Hydro will monitor these developments closely to determine if and when a new transformer station will be required. If a new transformer station is required to supply the industrial customers, it may potentially provide a second source of supply to the City of Kenora and surrounding areas. As this is a customer-driven need, it is not expected to have major regional implications.

6.2.3 Transmission End-of-Life Replacements and Sustainment Activities

The Dryden TS 115 kV/44 kV transformers and Moose Lake 115 kV/44 kV transformers are due for end-of-life replacements within the next five years. The Dryden 115 kV/44 kV transformers are scheduled to be replaced in 2016, with assets of at least equivalent capacity and specification based on Hydro One current standards. This sustainment decision was made prior to the initiation of this IRRP.

The Moose Lake 115 kV/44 kV transformers and associated 44 kV distribution lines are scheduled to be replaced in the early 2020s. The refurbished transformer station, with equally sized equipment and station reconfiguration, will improve the supply security to the customers and communities in Atikokan and the surrounding areas. As part of the IRRP, Atikokan Hydro and Hydro One Transmission examined potential sustainment options, including potential relocation of the 115kV/44kV, based on cost-benefit and cost allocation considerations. The details related to the end-of-life replacements for the Moose Lake 115 kV/44 kV transformers can be found in Appendix E.

Hydro One Transmission will be replacing wood pole structures on a number of aging 115 kV transmission lines in the Kenora, Sioux Lookout and Dryden areas and the 230 kV transmission lines in the Fort Frances and Atikokan areas. During the wood pole structure replacements, the electricity supply to local communities will be temporarily rerouted to other circuits. As a result, no service interruption is expected during construction. This sustainment decision was made prior to the initiation of this IRRP.

Going forward, the Working Group will need to better understand the timing and scope of upcoming sustainment activities in this sub-region, as sustainment activities may provide opportunities to replace these aging assets in a manner that also addresses broader regional needs.

6.2.4 Transmission Service Reliability and Performance

Many communities and customers in the sub-region are supplied by long transmission lines and rely on a single supply source. A few customers have expressed concerns regarding service reliability and performance. Service reliability and performance is measured based on customers' exposure to power outages on the distribution and transmission system, which is expressed in terms of *frequency* (i.e., number of outages a year) and *duration* (e.g., length of time

before the power is restored). Transmission customer delivery point standards are used to measure the service reliability and performance of the electricity system in Ontario.

In response to service reliability and performance concerns raised by communities and LDCs, the Working Group assessed the reliability performance of the transmission system in the West of Thunder Bay Sub-region, in particular, the 115 kV sub-systems supplying Town of Sioux Lookout and Town of Fort Frances. These sub-systems are supplied by a single transmission supply and have recently experienced outages. Based on historical reliability performance statistics, the 115 kV transmission system supplying Sioux Lookout and Fort Frances is within the provincial service reliability and performance standards. However, Hydro One Transmission indicated that during a recent maintenance outage, switching equipment failure resulted in a prolonged outage for customers in the Fort Frances area. Customers and communities may work with Hydro One Transmission to explore options to avoid similar incidents in the future.

A summary of transmission reliability performance assessment can be found in Appendix C. Section 7.2 will discuss the potential opportunities to further improve transmission service reliability and the associated cost implications.

6.3 Other Electricity Needs and Considerations

As discussed in Section 3, electricity planning is conducted at various levels: bulk, regional, local, and community (Figure 6-1). In addition to regional planning, bulk, distribution and community energy planning activities are also underway in the West of Thunder Bay Sub-region. While these needs are beyond the scope of regional planning process, bulk, distribution and community energy needs were taken into consideration in the development of the plan.

Figure 6-1: Electricity Planning at the Bulk, Regional, Distribution and Community Levels

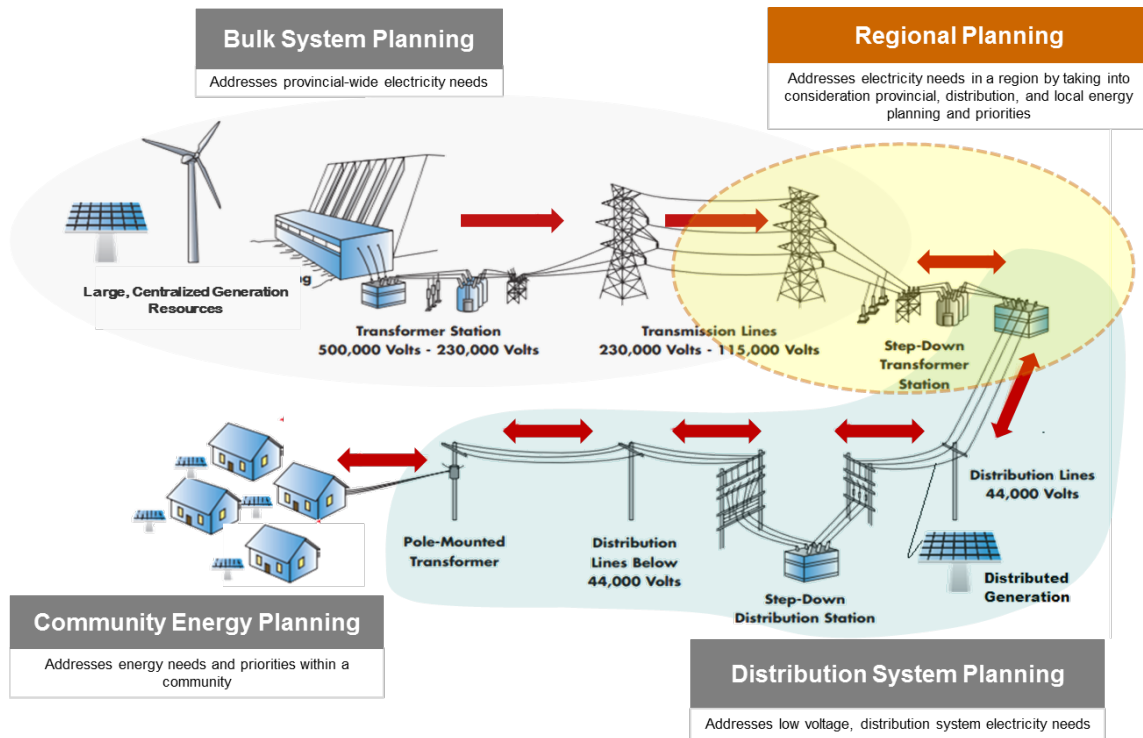

To provide the broader context, issues and considerations related to 230 kV bulk transmission system, the local distribution systems, and community energy planning activities and their implications on the West of Thunder Bay Sub-region will be discussed in the following sections.

6.3.1 230 kV Bulk System Needs

The 230 kV bulk transmission system supplying the West of Thunder Bay and North of Dryden Sub-regions is adequate today. As a result of potential industrial developments and remote community connections in the West of Thunder Bay and North of Dryden Sub-regions, the West of Thunder Bay 230 kV bulk transmission system may need to serve up to 500 MW of additional electricity demand over the planning period. The 230 kV bulk transmission system will require sufficient supply capacity to deliver power into the West of Thunder Bay and North of Dryden Sub-regions as shown in Figure 6-2.

Figure 6-2: 230 kV Supply into West of Thunder Bay and North of Dryden Sub-regions

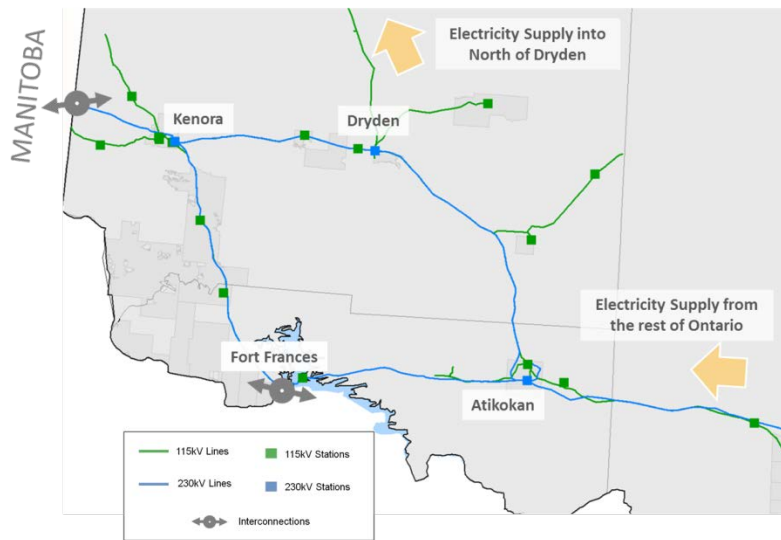

12

Given the limited supply margin remaining on the 230 kV bulk transmission system, potential demand growth and changes in the regional supply mix may lead to bulk system reliability needs in the sub-region. These needs are discussed below:

- **230 kV supply into the Dryden area:** The existing 230 kV bulk transmission system can supply a total of 175 MW of load in Dryden area and North of Dryden Sub-region. There is 50-100 MW of additional capacity remaining to support growth in the Dryden area and North of Dryden Sub-region.
- **230 kV supply into the West of Thunder Bay Sub-region:** The existing 230 kV bulk transmission system is adequate today, assuming generation at Atikokan is available. Currently, there is approximately 150 MW of supply margin remaining to support growth in the West of Thunder Bay and North of Dryden Sub-regions. If the Atikokan generation is unavailable, either because of biomass fuel limitations or contract termination (in 2024), the supply margin may be further reduced.

A bulk transmission system study is currently underway to assess the reliability of the 230 kV bulk transmission system supplying the West of Thunder Bay and North of Dryden Sub-regions. As part of the study, the IESO is exploring potential supply options including generation, transmission and firm imports from Manitoba.

In order to maintain the viability of the transmission option, the IESO has issued a hand-off letter to Hydro One to undertake early development work. To facilitate the development work, Hydro One has been engaging Infrastructure Ontario in exploring ways to ensure that the project is developed and delivered in a cost-effective manner and results in value for Ontario electricity customers. The preliminary scope of the transmission option (“Northwest Bulk Transmission Line Project”¹¹) consists of a new double-circuit 230 kV line between Thunder Bay and Atikokan and a single-circuit 230 kV line from Atikokan to Dryden. However, alternate routes may be considered as part of the development work.

6.3.2 Distribution System Needs

A number of distribution system needs were identified through engagement with communities and LDCs, including issues related to service reliability and performance, power quality and end-of-life replacements and sustainment activities. A summary of these issues is provided below. However, these needs will be formally addressed as part of the distribution planning process carried out by LDCs.

Distribution Service Reliability

In response to the service reliability and performance concerns raised by communities and LDCs, the Working Group assessed the reliability performance of the distribution systems in the West of Thunder Bay Sub-region. Results from the assessment show that the majority of distribution lines in this area perform well relative to other distribution lines in the province. However, there are two distribution lines supplying electricity to areas near Shabaqua and Margach that are performing below the provincial distribution system average. These distribution lines are three to four times longer than other distribution lines across the province. Long distribution lines typically exhibit lower levels of reliability because they are more exposed to tree and wildlife contact, and they sustain more damage from poor weather. Outages in rural areas with difficult terrain, also limits access by repair crews leading to increased restoration time. A summary of distribution reliability performance assessment can be found in Appendix D.

Section 7.2 will discuss the potential opportunities to further improve distribution service reliability and the associated cost implications.

¹¹ For more information on Northwest Bulk Transmission Line: <http://www.ieso.ca/Pages/Ontario's-Power-System/Regional-Planning/Northwest-Ontario/Bulk-Planning-Initiatives.aspx>

Power Quality

Some industrial customers in the sub-region are experiencing issues related to power quality. Power quality issues are defined as disturbances to the customer's supply as a result of voltage-related issues. These voltage issues can be driven by a combination of customers' equipment and/or system voltage performances. The solutions and the cost responsibility of investments to address power quality issues may vary depending on the root causes of the problem. The Working Group agreed that there needs to be a better understanding of power quality issues in this sub-region and that they should be examined on a case-by-case basis by the LDCs, transmitter and customers.

End-of-Life Replacement and Sustainment Activities

Based on information provided by Hydro One Distribution, three distribution stations ("DS") were refurbished over the last couple of years: Nestor DS, Sioux Narrows DS, and Burleigh DS.

6.3.3 Community Energy Planning

A number of communities in the sub-region are in the process of developing community energy plans. At the time of this report, 16 of the 26 First Nations communities have received funding from the IESO through the Aboriginal Community Energy Plan program to develop community energy plans. The City of Kenora, City of Dryden and Town of Sioux Lookout have also expressed interest in developing community energy plans and some plans are in the early stages of development. The Municipal Energy Plan Program¹² administered by the Provincial government supports municipalities in their efforts to develop a community energy plan.

Through community energy planning activities, communities will have a better understanding of their local energy needs and emissions footprint, will identify opportunities for energy efficiency and emissions reduction, and will develop plans to meet their goals in consideration of local economic development. These community energy plans examine broader energy needs, such as transportation, natural gas and electricity, and consider other objectives including net

¹² For more information on the Ministry of Energy MEP Program:

<http://www.energy.gov.on.ca/en/municipal-energy/>

zero energy, electrification, and emissions reductions. The development of these plans is being led by communities.

Given the growing concern with climate change and the move toward a low carbon economy, a CEP may include recommendations to promote electrification and other forms of fuel switching, such as shifting from natural gas to electric-power heat pumps, to achieve a goal of reducing greenhouse gas (“GHG”) emissions. As such, the outcomes from CEPs may drive additional requirements on the electricity system and should be monitored closely as part of the regional planning process. Furthermore, with the increased access to distributed energy resources, community energy plans may identify opportunities for community-based energy solutions, such as district energy, combined heat and power (“CHP”), or microgrids. Depending on the timing, location and magnitude of the needs, community-based energy solutions can be considered as potential options to address regional electricity needs.

6.4 Needs Summary

Table 6-1 provides a summary of the regional supply and reliability needs in the West of Thunder Bay Sub-region. These needs are within the scope of the regional planning process.

Table 6-1: Summary of Regional Supply and Reliability Needs

| Regional Electricity Reliability Needs | Components | Status |
|--|---|--|
| Supply Capacity | Dryden 115 kV sub-system | 50 MW of additional supply may be required around the mid-2020s under the High scenario |
| Transformer Station Capacity | The transformer station supplying the City of Kenora and surrounding areas (Kenora MTS) | Limited supply margin remaining on the transformer station. Additional capacity may be required in the next few years as a result of a distribution connection-request from industrial customers in the Kenora area. |

| | | |
|---|---|---|
| Transmission Service Reliability | Transmission supply to Town of Sioux Lookout and Town of Fort Frances | Based on historical outage statistics, the regional transmission system is within provincial service reliability and performance standards. During a recent maintenance outage, switching equipment failure resulted in a prolonged outage for customers in the Fort Frances area. |
| End-of-Life Replacements and Sustainment Activities | Dryden 44 kV/115 kV transformers | Scheduled to be replaced in 2016 |
| | Moose Lake 44 kV/115 kV transformers | Due for end-of-life replacements in early 2020s |
| | Aging 115 kV structures in Kenora, Fort Frances and Dryden area | These structures will be replaced within the next five years |

Table 6-2 provides a summary of the issues and considerations related to 230 kV bulk transmission system, local distribution systems, and community energy planning activities in the West of Thunder Bay Sub-region. Although these issues are beyond the scope of the regional planning study, the Working Group will continue to monitor these needs closely and keep LAC members informed of bulk, distribution and community planning activities in the sub-region.

Table 6-2: Other Electricity Needs and Considerations in the area

| Type | Needs | Status |
|------|--|--|
| Bulk | A potential need for additional supply on the 230 kV bulk system supplying the West of Thunder Bay and North of Dryden Sub-regions | Potential growth in the North of Dryden and West of Thunder Bay Sub-regions may exceed capability on the 230 kV bulk transmission system |

| | | |
|--------------|--|--|
| Distribution | Reliability Performance | Majority of distribution lines in this area perform well relative to other lines in the province, with the exception of the two distribution lines supplying to areas near Shabaqua and Margach. |
| | Power Quality | Some industrial customers are experiencing power quality issues, which could be driven by a combination of customers' equipment and/or system voltage performances. This will need to be investigated on a case-by-case basis. |
| | End-of-Life and Sustainment Activities | Nestor DS, Sioux Narrows DS, and Burleigh DS were refurbished over the last couple of years |
| Community | Greater coordination is required | A number of communities have expressed interest and some plans are in the early stages of development. |

7. Options to Address Potential Regional and Local Needs

In developing the 20-year plan, the Working Group considered a range of integrated solutions for addressing needs, including a mix of conservation, generation, transmission and distribution facilities, and other electricity system initiatives. When evaluating alternatives, the Working Group considers a number of factors, including technical feasibility, cost, flexibility, alignment with planning policies and priorities and consistency with long-term needs and options. Solutions that maximized the use of existing infrastructure were given priority, where they were otherwise determined to be cost effective.

Although investing in new electricity infrastructure, such as a new transmission line or a generation facility, can be a potential solution to address the electricity needs within a community, it requires substantial capital investment, has environmental/land-use impact and has a long-service life. As such, it is important to take into the consideration the longer-term cost implications, value and potential risks (e.g., stranded or underutilized assets) when recommending investment. Furthermore, these facilities typically require a long lead time to complete development, obtain approvals and complete construction. For this reason, commitment of these facilities must be made with sufficient lead time to ensure they are available when needed. When assessing the need for infrastructure investments, it is important to strike a balance between overbuilding infrastructure (e.g., committing to infrastructure when there is insufficient demand to justify the investment) and under-investing (e.g., avoiding or deferring investment despite insufficient infrastructure to support growth in the region). Typically, conservation solutions can be implemented within six months, or up to two years for larger projects, whereas transmission and distribution facilities can take five to seven years to come into service. The lead time for generation development is typically two to three years, but could be longer depending on the size and technology type.

Given the uncertainty with the location, timing and magnitude of the electricity demand growth in the West of Thunder Bay Sub-region, as discussed in Section 5, it is important to monitor development closely and create a flexible, comprehensive, integrated plan in anticipation of potential demand growth scenarios and varying supply conditions in the sub-region. At this time, early development work for major electricity infrastructure projects to address potential regional needs is not required. However, to lay the ground work for the next planning cycle, the Working Group has explored potential options to address the potential supply capacity needs on the 115 kV Dryden sub-system under the High scenario. There are opportunities for

communities and customers to work with LDCs and Hydro One Transmission to explore opportunities to further improve transmission and distribution service reliability and to assess the associated cost implications. Finally, the Working Group, with input from the LACs, has identified areas to facilitate greater coordination between community energy planning activities and regional planning.

These options and the opportunities to address these local and regional needs are discussed in the following section.

7.1 Options to Address Supply Capacity Needs on Dryden 115 kV Sub-system under the High Scenario

As discussed in Section 6.2.1, about 50 MW of additional supply capacity will be required on the Dryden 115 kV sub-system under the High scenario. Given the uncertainty with the demand growth, early development work for major electricity infrastructure projects is not required at this time. However, it is important to continue to monitor demand closely to determine if and when an investment decision for the Dryden 115 kV sub-system is required.

To lay the groundwork for the next planning cycle, the Working Group examined three conceptual approaches to address potential supply capacity needs on the Dryden 115 kV sub-system: conservation and distributed energy resources, delivering provincial resources (“wires” planning); and, large localized generation. In practice, certain elements of electricity plans will be common to all three approaches, and some overlap may be necessary. It is likely that all plans will contain some combination of conservation, local generation, transmission, and distribution elements. The following section describes the attributes, benefits, risks and implementation requirements associated with each of the three approaches.

As discussed in Section 6.3.1, additional reinforcements may be required to address the 230 kV bulk transmission needs in the West of Thunder Bay Sub-region and will be addressed separately as part of the bulk transmission planning process.

7.1.1 Conservation and Distributed Energy Resources

Conservation is important in managing demand in Ontario and plays a key role in maximizing the useful life of existing infrastructure and maintaining reliable supply. Conservation is achieved through a mix of program-related activities including behavioural changes by

customers and mandated efficiencies from building codes and equipment standards. These approaches complement each other to maximize conservation results.

However, within West of Thunder Bay Sub-region, the majority of the forecast load growth is anticipated to be driven by new industrial development, which is assumed to include relatively efficient equipment given the inherent economic benefits and the latest codes and standards. Conservation expected to be achieved through provincial targets, including time-of-use, codes and standards, and program delivery, has already been included in the planning forecast scenarios. Therefore, the potential for an additional amount of significant conservation that could address needs is limited.

Two of the available programs that transmission-connected industrial customers could be eligible for are the Industrial Conservation Initiative (“ICI”) and the Industrial Accelerator Program (“IAP”). The ICI encourages Class A customers to reduce their peak demand contributions, by providing a means to reduce their Global Adjustment charges.¹³ IAP is geared to reducing electricity consumption on the provincial system, and to helping companies become more competitive by providing financial incentives that encourage investment in innovative process changes and equipment retrofits.¹⁴ Opportunities for energy savings will continue to be explored for new and existing transmission-connected customers in the West of Thunder Bay Sub-region.

7.1.2 Large, Localized Generation Resources

Siting localized generation based on the size and location of the electricity requirements can be an effective means for addressing major regional supply and reliability needs over the long term. While this approach is similar to distributed energy resources in that it shares the goal of providing supply locally, the emphasis is on large, transmission-connected generation facilities rather than smaller, distributed resources. In the context of the West of Thunder Bay Sub-region, a 50 MW generation facility connected to the Dryden 115 kV sub-system can address the potential supply capacity needs under the High scenario.

There are a number of factors that need to be considered when siting localized generation, and any decisions would need to align with the recommendations found in the August 2013 report

¹³ More information on how Global Adjustment is calculated for Class A customers is available at <http://www.ieso.ca/Pages/Participate/Settlements/Global-Adjustment-for-Class-A.aspx>

¹⁴ More information on IAP is available at: <http://www.ieso.ca/Pages/Participate/Industrial-Accelerator-Program/default.aspx>

entitled “Engaging Local Communities in Ontario’s Electricity Planning Continuum”¹⁵ that was prepared for the Minister of Energy by the OPA and the IESO.

As the requirements in the West of Thunder Bay Sub-region are for additional capacity during times of peak demand, a large, transmission-connected generation solution would need to be capable of being dispatched when needed, and operate at an appropriate capacity factor. In some cases, additional transmission reinforcements may also be required. In addition, siting may be a challenge if the generation is to be located in populated or environmentally sensitive areas.

The cost of a large, localized generation resource depends on the size, fuel type, technology and the degree to which it can contribute to the local and provincial system capacity or energy needs. The fuel availability will also need to be taken in consideration. For example, there is limited natural gas storage capacity in northern Ontario, and the commitment timeframes for gas and electricity are not aligned. As such, procuring “firm” service in the northwest is expected to be more costly than in southern Ontario. The lead time for generation development is typically two to three years, but it could be longer depending on the size and technology type.

7.1.3 Delivering Provincial Resources (“Wires” Planning)

Delivering provincial resources, or “wires” planning, reflects the traditional regional electricity planning approach associated with the development of centralized electric power systems. This approach involves using transmission and distribution infrastructure to supply a region’s electricity needs by taking power from the provincial electricity system. This model takes advantage of generation that is planned at the provincial level, along with generation sources typically located remotely from the region. Utilities, both transmitters and distributors, play a lead role in the development of this approach.

Installing an additional 115/230 kV autotransformer in the Dryden and surrounding area can enable more power to be delivered from the 230 kV bulk transmission system to the 115 kV Dryden sub-system. A 115/230 kV autotransformer typically costs in the range of \$15 million to \$20 million and the lead time to develop a transformer is typically three to five years. These enhancements may be subject to regulatory approvals, such as a Class Environmental Assessment and utilities’ rate filings. The costs of “wires” solutions would depend not only on

¹⁵ <http://www.ieso.ca/Pages/Participate/Regional-Planning/Local-Advisory-Committees.aspx>

the specific infrastructure involved, but also on the cost of providing energy at the provincial system level. Cost responsibility for the transmission and distribution infrastructure would be determined as part of the regulatory application review process.

7.2 Opportunities to Further Improve Service Reliability

As discussed in Section 6.2.4 and Section 6.3.2, the reliability performance of the West of Thunder Bay Sub-region is generally within the provincial service reliability and performance standards. Communities and customers may consider working with LDCs and transmitter to explore opportunities to improve transmission and distribution service reliability and performance. Cost-benefit and cost allocation for investments will need to be considered.

At the distribution level, communities and customers may work with LDCs to identify mitigation measures to improve distribution service reliability, where applicable. Similarly, at the transmission-level, LDCs or transmission-connected customers may work with Hydro One Transmission to look at potential transmission improvements (e.g., switching facilities) to reduce the risk and impact of supply interruptions, especially during maintenance outages. Furthermore, many communities are interested in developing distributed energy resources. Communities may wish to explore opportunities for community-based solutions and emerging technologies, such as on-site generation and storage facilities, to minimize the impact of potential power outages.

Whether customers are looking at incremental distribution, transmission or community-based energy solutions to improve service reliability, consideration must be given to the cost-benefits and cost responsibility issues. According to the OEB's proposed "beneficiary pays" principle for cost-allocation, the responsibility to pay for higher reliability would likely be borne by the customers in the area. The issue of how much is appropriate to invest and who pays for the investments will need to be addressed.

The cost of improving service reliability varies depending on geography, the nature of the issue and the local system configuration. In the case of the West of Thunder Bay Sub-region, given the large geographical area and sparse population, solutions for improving system reliability performance may be very costly (e.g., a transmission line covering hundreds of kilometers), while the benefiting customer base may be relatively small. The Working Group has heard from communities and customers in this sub-region that below-average reliability is an impediment to economic development, while the investments necessary to improve the

situation are not affordable. However, minor improvements, such as switches and outage mitigation and maintenance measures (e.g., tree trimming and relocations of off-road distribution lines), and distributed energy resources, may be more cost-effective alternatives. In any case, the cost-benefit and responsibility of investments to further improve service reliability will need to be examined on a case-by-case basis.

7.3 Potential Areas for Coordination: Community Energy Planning and Regional Planning Activities

As discussed in Section 6.3.3, a number of communities are currently in the process of developing community energy plans. Greater coordination between community energy planning and regional planning processes can help provincial system planners and local communities develop a common understanding of the growth and local developments, identify opportunities to develop community-based energy solutions and have an informed dialogue on related energy issues.

With the input from the LACs, the Working Group identified potential areas for greater coordination:

- Status of local growth and developments
- Local planning priorities
- Local energy planning activities (e.g., community energy plan)
- Impact of potential supply interruptions or outages
- Potential, feasibility and challenges of implementing community-based energy solutions in consideration of cost-benefit and cost responsibility

LAC meetings can be used as a forum to facilitate the discussion on these energy and planning issues at the community, distribution, regional and bulk system levels. More importantly, these meetings can provide an opportunity for communities to share lessons learned and best practices from community energy planning activities across a region.

A number of coordination efforts are underway in Ontario to facilitate the development of community energy planning, such as the Quality Urban Energy Systems of Tomorrow (“QUEST”) initiative. Due to the unique energy planning challenges in the northwest, it would be helpful to identify initiatives to facilitate knowledge sharing and coordinate community energy planning activities in northern Ontario (e.g., a community energy planning webinar or workshop for communities in northern Ontario).

8. Recommended Actions

While specific solutions do not need to be committed to today, it is appropriate to begin work to gather information, monitor developments, continue to engage communities and develop alternatives to support decision-making for the next iteration of the IRRP for this sub-region. The plan sets out the actions required to ensure that options remain available to address future needs, if and when they arise.

Supply capacity needs on the Dryden 115 kV sub-system may emerge under the High scenario, but these potential needs do not require any immediate action. The Working Group will monitor demand growth closely to determine if and when an investment decision for the Dryden 115 kV sub-system is required. In the meantime, the Working Group will keep the communities informed about any developments at the bulk, regional and distribution levels. For communities and customers who are looking to further improve service reliability, they may consider working with LDCs and Hydro One Transmission to develop transmission, distribution and community-based solutions. However, cost-benefit and responsibilities will need to be taken into consideration. Communities in the West of Thunder Bay Sub-region have become increasingly involved in community energy planning activities. The results of early community energy planning initiatives, energy conservation initiatives, and achievable potential studies will be an important input to the next iteration of the plan for the West of Thunder Bay Sub-region. The LAC meetings can be an opportunity to help facilitate greater coordination between the local and regional electricity planning activities.

The recommended actions and deliverables for the plan are outlined in Table 8-1, along with the proposed timing and the parties assigned lead responsibility for implementation. The West of Thunder Bay Working Group will continue to meet regularly during the implementation phase of this IRRP to monitor developments in the West of Thunder Bay Sub-region and track progress of these deliverables.

Table 8-1: Recommended Actions

| Recommendations | | Action(s)/Deliverable(s) | Lead Responsibility | Timeframe |
|-----------------|--|--|--|-----------|
| 1 | Monitor electricity demand growth closely to determine if and when a decision on Dryden 115 kV sub-system is required | Review electricity demand growth in the West of Thunder Bay and the North of Dryden Sub-regions with the members of the LACs | Working Group | Annually |
| 2 | Ensure communities are informed of bulk and distribution planning activities in the West of Thunder Bay Sub-region | Provide a status update on bulk and distribution planning activities at LAC meetings | Working Group | On-going |
| 3 | Explore opportunities to further improve service reliability and power quality in consideration of cost-benefit and cost allocations | Examine cost benefit and cost responsibility of distribution, transmission and/or community-based energy solutions | Customers, local distribution companies, and transmitter | On-going |
| 4 | Coordinate regional and community energy planning activities | Use LAC meetings as an opportunity to share best practices and to coordinate regional and local energy planning activities | Working Group and Communities | On-going |
| | | Identify opportunities to facilitate knowledge sharing and to coordinate community energy planning activities in northern Ontario, such as webinars on community energy planning in northern Ontario | | |

9. Community and Stakeholder Engagement

Community engagement is an important aspect of the regional planning process. Providing opportunities for input in the regional planning process enables the views and preferences of the community to be considered in the development of the plan, and helps lay the foundation for successful implementation. This section outlines the engagement principles as well as the engagement activities undertaken to date and next steps for the West of Thunder Bay IRRP.

A phased community engagement approach was undertaken for the West of Thunder Bay IRRP based on the core principles of creating transparency, engaging early and often, and bringing communities to the table. These principles were established as a result of the former OPA and the IESO's outreach with Ontarians in 2013 to determine how to improve the regional planning and siting process, and they now guide IRRP outreach with communities and will ensure this dialogue continues as the plan moves forward.

Summary of the West of Thunder Bay Community Engagement Process



9.1 Creating Transparency

To start the dialogue on the West of Thunder Bay IRRP and build transparency in the planning process, a number of information resources were created for the plan. A dedicated web page was created on the IESO website including a map of the regional planning area, information on why an IRRP was being developed for the West of Thunder Bay Sub-region, the IRRP Terms of Reference and a listing of the organizations involved. A dedicated email subscription service

was also established for the broader Northwest Ontario planning region where communities and stakeholders could subscribe to receive email updates about the IRRP.

9.2 Engage Early and Often

Early communication and engagement activities for the West of Thunder Bay IRRP were initiated in October 2014 as part of a series of meetings with communities and stakeholders to discuss electricity planning initiatives across northwest Ontario. The main objective of the meetings from a regional planning perspective was to introduce attendees to the regional planning process. This included the Northwest Ontario Scoping Assessment process for the regional planning studies being initiated in the area, as well as discussions of upcoming engagement activities. Various meetings were held with a broad range of attendees including municipal representatives, First Nation community members, Métis council members, federal and provincial representatives, electricity customers, Common Voice Northwest, transmission and generation project developers, and others.

9.2.1 Northwest Ontario Scoping Assessment Outcome Report

The draft Northwest Ontario Scoping Report was posted to the IESO website in December 2014 for comment. Following this comment period, the final scoping report was posted on January 27, 2015.

9.2.2 First Nation and Métis Community Meetings

Meetings with First Nation communities are one of the first steps in engagement for all regional plans. Initial meetings were held in Dryden, Fort Frances and Kenora in June and July 2015. The purpose of these meetings was to discuss the development of the IRRP and share the initial findings. During these meetings, community members indicated their participation in community energy planning as well as interest in local small renewable projects. Communities also gave information about developments in their community and the growing population. Concern was also raised about service outages and the cost of electricity.

On April 18, 2016, the IESO met with Dalles (Ochiichagwe’ Babigo’ Ining) Ojibway Nation to discuss the status of planning and the identified needs in the West of Thunder Bay area. The community also raised concerns about high electricity costs and the impact of hydroelectric power and other electricity infrastructure on their community.

The IESO invited all other local First Nations communities and Métis councils to similar meetings and remains open to further engagement on the plan.

9.2.3 Municipal Meetings

Meetings with area municipalities are also one of the first steps in engagement for all regional plans. In June and July 2015, the Working Group held group municipal meetings in Dryden, Fort Frances and Kenora to discuss the development of the IRRP as well as the findings to date. Attendees were generally pleased with the meetings and the opportunity to offer a local perspective, and they looked forward to the development of the LACs. During these meetings, many communities also indicated they were interested in developing community energy plans and wanted to find out more about how these plans and the IRRP could work together.

9.3 Bringing Communities to the Table

To continue the dialogue on regional planning, two LACs – a general LAC and a First Nations LAC - were established for the West of Thunder Bay regional planning area in fall 2015. The role of LACs is to provide advice and recommendations on the development of the regional plan as well as to provide input on broader community engagement. General LACs are comprised of Indigenous, municipal, environmental, business, sustainability and community representatives. First Nations LACs are comprised of representatives from the First Nation communities in the planning area. All general LAC meetings are open to the public and meeting information is posted on the dedicated engagement webpage, which in this case is the IESO's West of Thunder Bay engagement web page¹⁶. The general LAC meetings are also broadcast as live webinars to enable participation from across the planning region.

Development of the West of Thunder Bay general LAC was completed through a request for nominations process promoted by the following activities in July/August 2015: advertisements in local newspapers across the planning area and in Thunder Bay newspapers; localized digital advertising; emails sent to municipal representatives across the region; and an e-blast sent to the IESO's Northwest Ontario subscribers list. Two Métis Councils in the West of Thunder Bay area appointed a member to the general LAC. The development of the West of Thunder Bay First Nations LAC was established through a letter to the leadership of each First Nation in the

¹⁶ <http://www.ieso.ca/Pages/Participate/Regional-Planning/Northwest-Ontario/West-of-Thunder-Bay.aspx>

West of Thunder Bay area inviting them to appoint a representative to the First Nations LAC. The First Nations LAC then appointed members to the general LAC.

The first meetings of the West of Thunder Bay LACs were held on November 18-19, 2015 in Dryden. The focus of these meetings was to introduce the regional planning process to the newly formed LACs, highlight key electricity supply issues and considerations in the West of Thunder Bay area, and determine the purpose and scope of the LACs. Material from the two LAC meetings and a web archive of the general LAC meeting can be accessed online.¹⁷

On April 19-20, 2016, the second general and First Nation LAC meetings were held in Dryden. The focus of these meetings was to provide an update on electricity planning activities in the area, review the draft outcomes of the West of Thunder Bay IRRP and determine key areas of focus for future LAC meetings. Material from the two LAC meetings and a web archive of the general LAC meeting can be accessed online.

Copies of the meeting summaries from the West of Thunder Bay general LAC meetings can be found in Appendix F.

Moving forward, the Working Group will present the final IRRP to both of the West of Thunder Bay LACs and discuss with members how they would like to continue the dialogue on regional planning in the area, as well as other electricity issues brought up by the LAC members, but that are outside the scope of regional planning.

The IESO is committed to undertaking early and sustained engagement to enhance regional electricity planning. Further information on the IESO's regional planning processes is available on the IESO website. Additional information on outreach activities for the West of Thunder Bay IRRP can be found on the IESO webpage and updates will continue to be sent to all Northwest Ontario Region email subscribers.

9.4 Additional Meetings and Presentations

The IESO recognizes Common Voice Northwest's unique mandate that includes investigating and making recommendations to the Northwest Ontario Municipal Association ("NOMA") on issues related to energy in the Northwest Ontario Region. The IESO continues to meet regularly

¹⁷ <http://www.ieso.ca/Pages/Participate/Regional-Planning/Northwest-Ontario/West-of-Thunder-Bay.aspx>

with Common Voice Northwest to discuss the status of electricity planning for northwestern Ontario.

The IESO also presents regularly at the NOMA Spring Annual General Meeting and Fall Regional Conference, the Association of Municipalities of Ontario conference, as well as the Ontario Mining Association conference, among others. These presentations have included high-level status updates on the development of the West of Thunder Bay IRRP, along with other electricity topics.

10. Conclusion

This report documents the IRRP that has been carried out for the West of Thunder Bay Sub-region and fulfills the OEB's regional planning requirement for the sub-region. The IRRP identifies electricity needs in this sub-region over the 20-year period from 2015 to 2034.

Aside from the potential need for additional supply on the 230 kV bulk transmission system, there are no major regional needs identified in the West of Thunder Bay Sub-region under the Low and Reference scenarios. An additional 50 MW of supply may be required on the Dryden 115 kV sub-system under the High scenario. However, early development work for major electricity infrastructure projects is not required at this time given the uncertainty with the demand forecast. The Working Group will monitor demand growth closely to determine if and when an investment decision for the Dryden 115 kV sub-system is required. Although the transmission and distribution reliability performance of the West of Thunder Bay Sub-region is within the provincial service reliability and performance standards, communities and customers may consider working with LDCs and Hydro One to explore opportunities to further improve transmission and distribution service reliability with consideration given to cost-benefits and responsibility for investments. In the meantime, a number of communities in this sub-region are currently developing community energy plans. LAC meetings can be used as an opportunity to share best practices and to coordinate regional and local energy planning activities.

The West of Thunder Bay Working Group will continue to meet regularly throughout the implementation of the plan to monitor progress and developments in the sub-region, and will produce annual update reports that will be posted on the IESO website. To support development of the plan, a number of actions have been identified to develop alternatives, engage with the community, and monitor growth in the area, and responsibility has been assigned to appropriate members of the Working Group for these actions. Information gathered and lessons learned from these activities will inform development of the next iteration of the IRRP for the West of Thunder Bay Sub-region. The plan will be revisited according to the OEB-mandated 5-year schedule.