

# LONDON AREA REGION SCOPING ASSESSMENT OUTCOME REPORT



## Scoping Assessment Outcome Report Summary

<b>Region:</b>	London and surrounding areas		
<b>Start Date</b>	May 5, 2015	<b>End Date</b>	August 28, 2015 <sup>1</sup>

### 1. Introduction

This Scoping Assessment Outcome Report is part of the Ontario Energy Board's ("OEB" or "Board") Regional Planning process. The Board endorsed the Planning Process Working Group's Report to the Board in May 2013 and formalized the process timelines through changes to the Transmission System Code and Distribution System Code in August 2013.

The first stage in the regional planning process, the Needs Assessment, was carried out by the Study Team lead by Hydro One Networks Inc. ("Hydro One") for the London Area. The final Needs Assessment report<sup>2</sup> was issued on April 3, 2015 and concluded that some needs in the region may require regional coordination, and these needs should be reviewed further under the IESO-led Scoping Assessment process.

The IESO, in collaboration with the Regional Participants, further reviewed the needs identified, in combination with information collected as part of the Needs Screening, and information on potential wires and non-wires alternatives, to assess and determine the best planning approach for the whole or parts of the region: an integrated regional resource plan ("IRRP"), a regional infrastructure plan ("RIP") or that regional coordination is not required and the planning can simply be done between the Transmitter and its customers.

This Scoping Assessment report:

- Defines the sub-regions for needs requiring regional coordination as identified in the Needs Screening report;
- Determines the appropriate regional planning approach and scope for each sub-region with identified needs requiring regional coordination;
- Establishes a Terms of Reference in the case where an IRRP and/or wires planning is the recommended approach for the sub-region(s);
- Establishes a working group for each sub-region recommended for an IRRP or wires planning.

<sup>1</sup> As per city of London's request, the public comment period has been extended. The end date is adjusted accordingly.

<sup>2</sup> The Needs Assessment report for the London region can be found at <http://www.hydroone.com/RegionalPlanning/LondonArea/Documents/Needs%20Assessment%20Report%20-%20London%20Region%20-%20April%20,%202015.pdf>

## 2. Team

The Scoping Assessment was carried out with the following Regional Participants:

- Independent Electricity System Operator (“IESO”)
- Hydro One Networks Inc. (“Hydro One Transmission”)
- Hydro One Networks Inc. (“Hydro One Distribution”)
- Entegrus Power Lines
- Erie Thames Power Lines Corporation
- London Hydro Inc.
- St. Thomas Energy Inc.
- Tillsonburg Hydro Inc.
- Woodstock Hydro Services Inc.

## 3. Categories of Needs, Analysis and Results

### I. Overview of the Regional Electricity System

The London Area is located in South-western Ontario and includes all or part of the following Counties, and Cities: Oxford County, Middlesex County, Elgin County, Norfolk County, the City of Woodstock, the City of London, and the City of St. Thomas. For electricity planning purposes, the planning region is defined by electricity infrastructure boundaries, not municipal boundaries.

The region also includes the following First Nations:

- Chippewas of the Thames
- Oneida Nation of the Thames
- Munsee-Delaware Nation

The electricity infrastructure supplying the London Area region is shown in Figure 1. The region is supplied from 115 kV and 230 kV transmission lines and stations that connect at the Buchanan and Longwood transformer stations (“TS”). The 500/230 kV auto-transformers at Longwood TS and the 230/115 kV auto-transformers at Buchanan TS and Karn TS provide the major source of supply to the area. Figure 2 shows the electricity infrastructure in the region in a single line diagram.

The region is summer-peaking (i.e., electricity demand is highest during the summer months) and had a peak demand of approximately 1250 MW in 2014. The region is characterized by gradual forecast growth with demand in some pockets slightly exceeding the supply capacity of the infrastructure.

**Figure 1. Map of London Region**

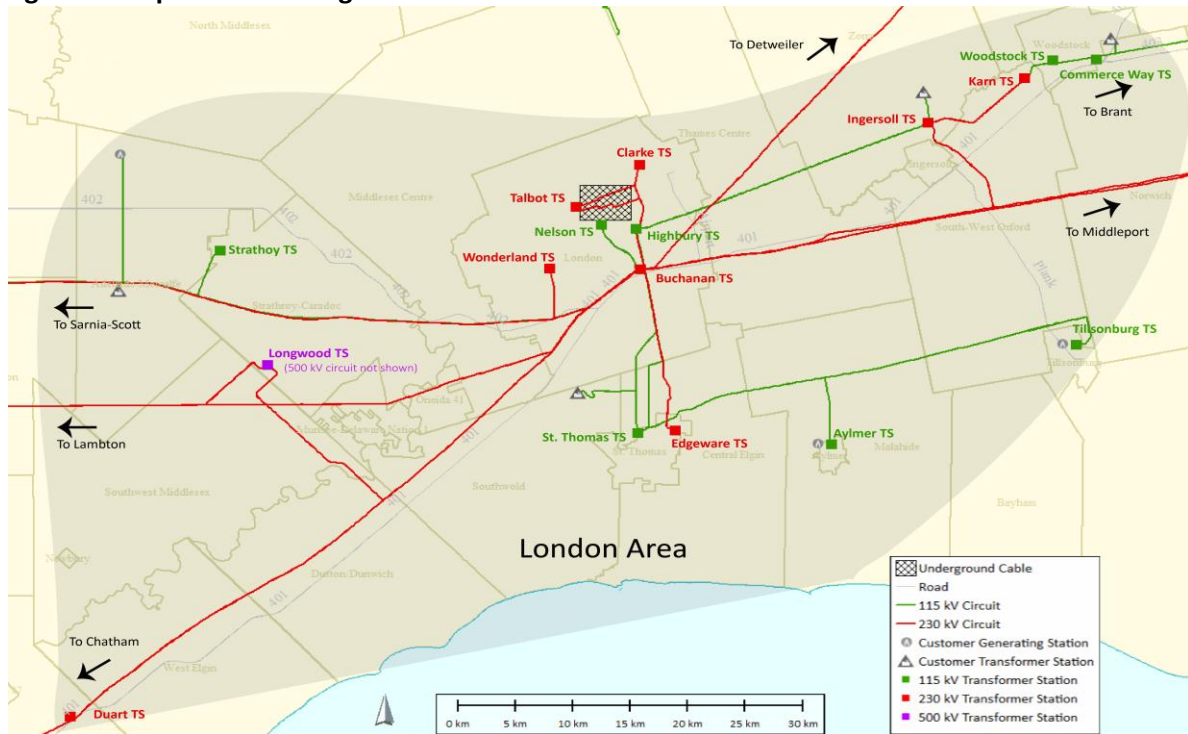

NOTE: Region is defined by electricity infrastructure; geographical boundaries are approximate.

**Figure 2. Single Line Diagram for London Region**

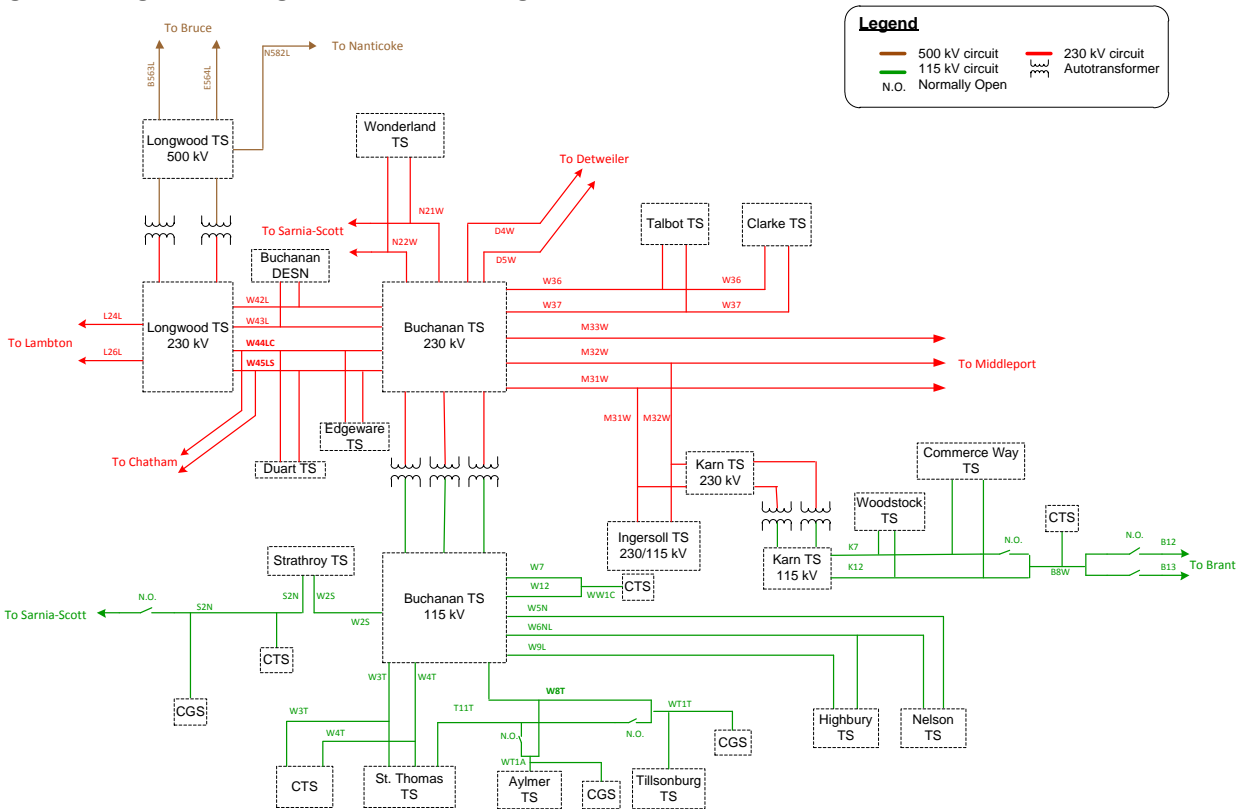

## II. Results from Need Screening Studies

Hydro One's Needs Assessment report identified the following needs in the London Area, based on a 10-year demand forecast.

### CAPACITY

#### Line Capacity

- The single 115 kV circuit W8T, which supplies Aylmer TS and Tillsonburg TS from Buchanan TS, is expected to reach its thermal capacity in the medium-term.

No other capacity needs were identified for the 230 kV and 115 kV transmission lines serving the area.

#### Station Capacity

- Four stations<sup>3</sup> in the London region have exceeded or are expected to exceed their supply capacity over the study period: Aylmer TS, Strathroy TS, Tillsonburg TS and Wonderland TS.

### LOAD RESTORATION

Hydro One's Needs Screening identified potential restoration needs<sup>4</sup> and this study confirms these needs as follows:

Circuits	Load Restoration Criterion not met
M31W+M32W <sup>5</sup>	4 hours
W36 + W37	30 min and 4 hours

### AGING INFRASTRUCTURE / REPLACEMENT PLANS

The following infrastructure is expected to reach its end-of-life or is the subject of sustainment activities within the study period.

Equipment	Estimated Completion Date
Aylmer TS- undergoing end of life plan	2019
Nelson TS DESN <sup>6</sup> - undergoing end of life replacements	2018
Strathroy TS <sup>7</sup> - one transformer is to be replaced within the next five years	2017

<sup>3</sup> Hydro One's Need Screening report listed six stations with capacity limitations. Subsequent to the Needs Assessment, it has been clarified that no station capacity needs at Clarke TS and Talbot TS.

<sup>4</sup> Hydro One's need screening identified potential restoration concerns for loss of N21/22W exceeding 150 MW due to loss of Wonderland TS, Modeland TS and Wanstead TS (based on the new SIA). However, both Modeland TS and Wanstead TS are out of the scope of this region and will be considered as part of Group 3 regional planning.

<sup>5</sup> The load restoration criterion not met on M31/32W refers to the loss of the Ingersoll tap that would result in losing Ingersoll TS, and Commerce Way TS, Woodstock TS and CTS following the loss of the autos at Karn TS.

<sup>6</sup> Nelson TS is undergoing end of life replacement and will be redeveloped at 27.6 kV instead of the previous 13.8 kV. This project is underway between Hydro One and London Hydro.

## OTHER

- Historical data shows that Buchanan DESN power factor may be below criteria under peak load conditions.
- IESO operations identified that under peak conditions if Buchanan TS 115 kV capacitors are in service, it is a challenge to place additional 230 kV capacitors in service.
- A number of 230 kV circuits in the region were identified to be overloaded under certain high generation conditions.

### III. Analysis of Needs

#### a. Identification of Sub-Regions

The Regional Participants have identified five sub-regions in the London Area based on electrical supply and service boundaries that require consideration as part of this Scoping Assessment as shown in Figure 3.

**Figure 3. Map with Sub-regions**

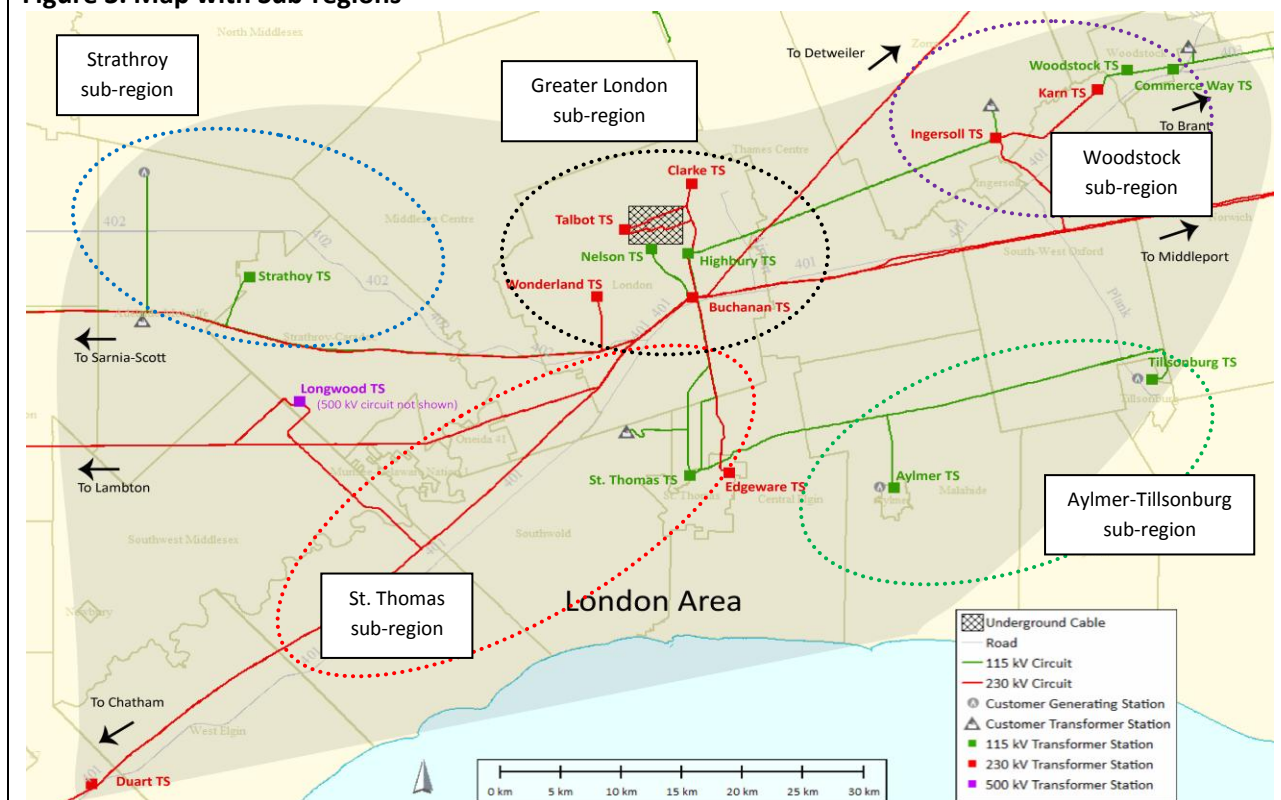

<sup>7</sup> The end of life activities at Strathroy TS were provided by Hydro One after the Needs Screening report was finalized.

## **1. Greater London Sub-Region**

In 2014, the Greater London area reached peak electricity demand of approximately 740 MW. Going forward, typical electricity demand growth is forecasted for this area.

This sub-region includes the following infrastructure:

- Stations—Buchanan DESN, Clarke TS, Highbury TS, Nelson TS, Talbot TS, Wonderland TS
- Transmission circuits—W36/37, N21/22W, W5N/W6NL/W9L
- 230/115 kV auto-transformers at Buchanan TS

Customers in this sub-region are supplied by London Hydro and Hydro One Distribution.

The needs in this sub-region include addressing transformation capacity limitation at the Wonderland transformer station<sup>8</sup> and meeting load restoration criteria on circuits W36/37 that supply over 350 MW of load.

While both capacity and load restoration needs have been identified in this sub-region, wires and non-wires options must be considered. In addition, the decisions made in this area will have broad impacts, involving multiple LDCs and relevant ratepayers. Therefore, the Regional Participants propose that this sub-region be studied through the IRRP process.

## **2. Aylmer-Tillsonburg Sub-Region**

In 2014, this sub-region reached peak electricity demand of approximately 108 MW. Going forward, typical load growth is forecast for this area.

This sub-region includes the following infrastructure:

- Stations—Aylmer TS, Tillsonburg TS
- Transmission circuits—115 kV circuits: W8T, WT1T, WT1A, T11T

Customers in this sub-region are supplied by Erie Thames Powerlines, Tillsonburg Hydro and Hydro One Distribution.

The needs in this sub-region include addressing overloaded transformers at Aylmer TS and Tillsonburg TS, voltage issues at Tillsonburg TS, and thermal overloading on the circuit W8T that supplies both these stations as identified in Hydro One's Needs Screening.

The transformation capacity need at Aylmer is planned to be addressed by an end of life replacement of Aylmer TS (this process was already underway by Hydro One Networks prior to the start of this scoping assessment).

---

<sup>8</sup> Subsequent to the Needs Assessment, contracts have been executed for the refurbishment of Nelson TS at 27.6kV and for 18MW of generation under CHPSOP. This is estimated to provide additional 70MVA of transformation capacity for the area.

As the end of life plan at Aylmer TS is a wires solution and is already under way, other needs including the voltage decline at Tillsonburg TS and the need for capacity on the 115 kV circuit W8T could be more efficiently addressed by way of a combined wires plan that considers all three needs in the area. Therefore, the Regional Participants recommend that the needs within this sub-region be addressed as part of a Hydro One led wires planning.

### **3. Strathroy Sub-Region**

In 2014, this sub-region reached peak electricity demand of approximately 63 MW. Going forward, typical load growth is forecast for this area.

This sub-region includes the following infrastructure:

- Stations—Strathroy TS
- Transmission circuits—W2S, S2N

Customers in this sub-region are supplied by Entegrus and Hydro One Distribution.

Hydro One's Needs Assessment report indicated that Strathroy TS is forecasted to exceed its station capacity. Based on Hydro One's information, there is a sustainment plan to replace T2 which is approaching end of life. Therefore, it is recommended that the capacity needs in this sub-region are best addressed as local planning between the relevant LDCs and Hydro One Transmission.

### **4. Woodstock Sub-Region**

In 2014, this sub-region reached peak electricity demand of approximately 170 MW. Going forward, typical load growth is forecast for this area.

This sub-region includes the following infrastructure:

- Stations— Ingersoll TS, Woodstock TS and Commerceway TS, KarnTS
- Transmission circuits—M31/32W, K7/K12, B8W

Customers in this sub-region are supplied by Woodstock Hydro and Hydro One Distribution.

The need in this area is to meet restoration criteria for the loss of double circuits M31/32W, specifically the Ingersoll tap that would result in a loss of approximately 180 MW of load. To meet the ORTAC criteria, which requires the amount of load in excess of 150 MW to be restored within approximately 4 hours, there is a need for a plan to restore approximately 30 MW of load within 4 hours for this sub-region.

As load restoration is the only need in this area, the Regional Participants agreed that this does not require regional coordination and can be addressed through local planning involving Hydro One transmission and the affected LDCs.



## **5. St. Thomas Sub-Region**

In 2014, this sub-region reached peak electricity demand of approximately 107 MW. Going forward, typical load growth is forecast for this area.

This sub-region includes the following infrastructure:

- Stations— Edgware TS, St. Thomas TS
- Transmission circuits—W3/4T, W44LC, W45LS

Customers in this sub-region are supplied by St. Thomas Energy Inc., London Hydro and Hydro One Distribution.

No needs have been identified in this sub-region, thus no further regional planning is recommended for this sub-region.

### **b. Other findings**

#### **i. Operational Items**

The Regional Participants agree that the following needs do not require regional coordination and can be addressed between Hydro One Networks and the relevant LDC (s), or Hydro One Networks and the IESO as required:

- Low power factor at Buchanan DESN
- Switching in of 230 kV capacitor banks and 115 kV capacitor banks at Buchanan TS

#### **ii. Bulk System**

The 230 kV circuits W44LC, W45LS, N21/22W are bulk system assets and connect the generation from Sarnia to the rest of Southwestern Ontario. It was noted that under high transfer conditions from west to east and/or high generation conditions, these circuits may become overloaded. Although this may create some congestion, this is not expected to create any local or global reliability concerns. The IESO will continue to monitor the congestion on these circuits.

## 4. Conclusion

The Scoping Assessment concludes that:

- An IRRP be undertaken to address the needs identified in the Greater London sub-region
- Wires planning led by Hydro One Networks to address the needs identified in the Aylmer-Tillsonburg sub-region. Ultimately the wires plan will be part of the RIP for the London Area region.
- Additional needs identified in the Needs Assessment will be addressed through other processes as follows:
  - Strathroy sub-region- local planning by Hydro One Networks and LDC(s)
  - M31/32W restoration needs - local planning by Hydro One Networks and LDC(s)
  - Low power factor at Buchanan DESN— to be coordinated between Hydro One Networks and LDC(s)
  - Switching in 230 kV and 115 kV capacitor banks at Buchanan TS - to be coordinated between Hydro One Networks and IESO

The draft Terms of Reference for the Greater London sub-region IRRP and the Aylmer-Tillsonburg sub-region wires planning are attached. The draft Terms of Reference will be finalized once the studies are kicked off.

# Greater London IRRP Terms of Reference

## 1. Introduction and Background

These Terms of Reference (ToR) establish the objectives, scope, key assumptions, roles and responsibilities, activities, deliverables and timelines for an Integrated Regional Resource Plan of the Greater London sub-region (to be referred to as the Greater London IRRP).

Based on the potential for demand growth within this sub-region, limits on the capability of the transmission capacity supplying the area, and opportunities for coordinating demand and supply options, an integrated regional resource planning approach is recommended.

### Greater London sub-region

The Greater London sub-region is a summer-peaking area that includes the City of London, and customers in surrounding municipalities supplied from Buchanan DESN, Clarke, Highbury, Nelson, Talbot, and Wonderland transformer stations (TS). The approximate geographical boundaries of the sub-region are shown in Figure 1.

Figure 1. Greater London Sub-Region

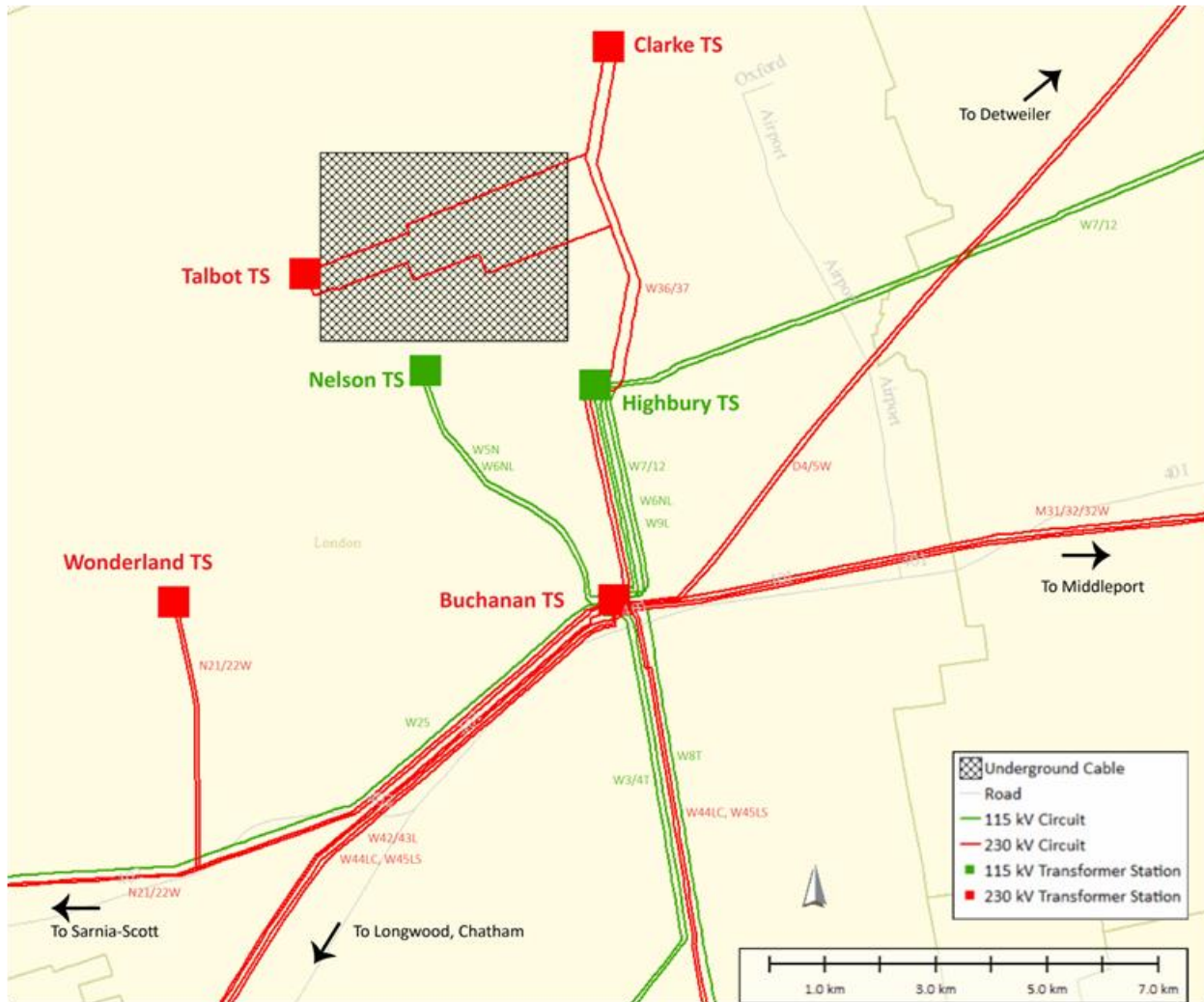

Source: IESO

NOTE: Region is defined by electricity infrastructure; geographical boundaries are approximate.

The sub-region includes all or part of the following municipalities:

- City of London
- London Township
- Nissouri Township
- Perth South Township
- Delaware Township
- Dorchester North Township

## Greater London Electricity System

The electricity system supplying the Greater London sub-region is shown in Figure 2.

**Figure 2. Greater London Electricity System**

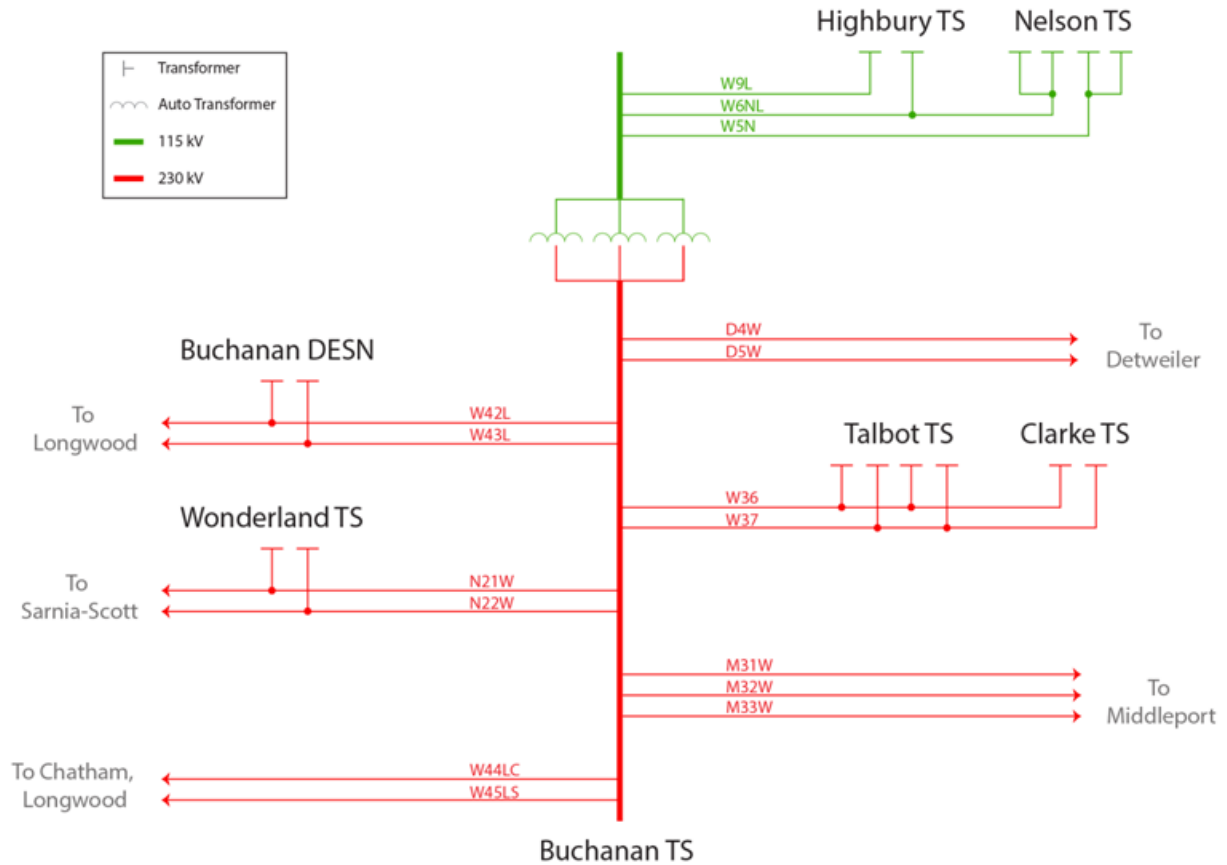

Source: IESO

## 2. Objectives

1. To assess the adequacy of electricity supply to customers in the Greater London sub-region over the next 20 years.
2. To coordinate customer-driven electricity needs with major asset renewal needs, and develop a flexible, comprehensive, integrated electricity plan for the Greater London sub-region.
3. To develop an implementation plan, while maintaining flexibility in order to accommodate changes in key assumptions over time.

## 3. Scope

This IRRP will develop and recommend an integrated plan to meet the needs of the Greater London sub-region. The plan is a joint initiative involving London Hydro, Hydro One Distribution, Hydro One

Transmission, and the IESO, and will incorporate input from community engagement. The plan will integrate forecast electricity demand growth, conservation and demand management (“CDM”) in the area with transmission and distribution system capability, end-of-life of major facilities in the area, relevant community plans, other bulk system developments, and FIT and other generation uptake through province-wide programs, and will develop an integrated plan to address needs.

This IRRP will address regional needs in the Greater London area, including capacity, security, reliability and relevant end of life consideration of assets. The following existing infrastructure and assumptions are included in the scope of this study:

- Stations—Buchanan DESN, Clarke TS, Highbury TS, Talbot TS, Wonderland TS
- Transmission circuits—W36/37, N21/22W, W5N/W6NL/W9L
- 230/115 kV auto-transformers at Buchanan TS
- Nelson TS is assumed to be redeveloped with low side voltage at 27.6 kV and will be considered as an option of providing load transfer relief to other stations once redeveloped

The Greater London IRRP will:

- Prepare a 20-year electricity demand forecast and establish needs over this timeframe.
- Examine the Load Meeting Capability and reliability of the existing transmission system supplying the Greater London sub-region, taking into account facility ratings and performance of transmission elements, transformers, local generation, and other facilities such as reactive power devices.
- Establish feasible integrated alternatives to address remaining needs, including a mix of CDM, generation, transmission and distribution facilities, and other electricity system initiatives in order to address the needs of the Greater London sub-region.
- Evaluate options using decision-making criteria including but not limited to: technical feasibility, economics, reliability performance, environmental and social factors.

#### **4. Data and Assumptions**

The plan will consider the following data and assumptions:

- Demand Data
  - Historical coincident peak demand information for the sub-region
  - Historical weather correction, median and extreme conditions
  - Gross peak demand forecast scenarios by sub-region, TS, etc.
  - Coincident peak demand data including transmission-connected customers
  - Identified potential future load customers
- Conservation and Demand Management
  - LDC CDM plans
  - Incorporation of verified LDC results and progression towards OEB targets, and any other CDM programs/opportunities in the area
  - Long-term conservation initiative

- Conservation potential studies, if available
- Potential for CDM at transmission-connected customers' facilities
- Local resources
  - Existing local generation, including distributed generation ("DG"), district energy, customer-based generation, Non-Utility Generators and hydroelectric facilities as applicable
  - Existing or committed renewable generation from Feed-in-Tariff ("FIT") and non-FIT procurements
  - Future district energy plans, combined heat and power, energy storage, or other generation proposals
- Relevant local plans, as applicable
  - LDC Distribution System Plans
  - Community Energy Plans and Municipal Energy Plans
- Criteria, codes and other requirements
  - Ontario Resource and Transmission Assessment Criteria ("ORTAC")
    - Supply capability
    - Load security
    - Load restoration requirements
  - NERC and NPCC reliability criteria, as applicable
  - OEB Transmission System Code
  - OEB Distribution System Code
  - Reliability considerations, such as the frequency and duration of interruptions to customers
  - Other applicable requirements
- Existing system capability
  - Transmission line ratings as per Hydro One transmission records
  - System capability as per current IESO PSS/E base cases
  - Transformer station ratings (10-day LTR) as per asset owner
  - Load transfer capability
  - Technical and operating characteristics of local generation
- Bulk System considerations to be applied to the existing area network
  - Buchanan auto transformer capability
  - NPLIP interface flow assumptions
- End-of-life asset considerations/sustainment plans
  - Transmission assets
  - Distribution assets
- Other considerations, as applicable

## **5. Working Group**

The core Working Group will consist of planning representative/s from the following organizations:

- Independent Electricity System Operator (*Team Lead for IRRP*)
- Hydro One Transmission
- London Hydro
- Hydro One Distribution

### Authority and Funding

Each entity involved in the study will be responsible for complying with regulatory requirements as applicable to the actions/tasks assigned to that entity under the implementation plan resulting from this IRRP. For the duration of the study process, each participant is responsible for their own funding.

## **5. Engagement**

Integrating early and sustained engagement with communities and stakeholders in the planning process was recommended to and adopted by the provincial government to enhance the regional planning and siting processes in 2013. These recommendations were subsequently referenced in the 2013 Long Term Energy Plan. As such, the Working Group is committed to conducting plan-level engagement throughout the development of the Greater London IRRP.

The first step in engagement will consist of meetings with municipalities, First Nation communities within the planning area, and those who may have an interest in the planning area, and the Métis Nation of Ontario; with the purpose of discussing regional planning, the development of the Greater London plan, and integrated solutions.

Typically this will be followed by the establishment of a Local Advisory Committee for local community members to provide input and recommendations throughout the planning process, including information on local priorities and ideas on the design of community engagement strategies. Broad community engagement will be conducted to obtain public input in the development of the plan.



## 6. Activities, Timeline and Primary Accountability

	Activity	Lead Responsibility	Deliverable(s)	Timeframe
1	<b>Prepare Terms of Reference considering stakeholder input</b>	<i>IESO</i>	- Finalized Terms of Reference	Q3 2015
2	<b>Develop the Planning Forecast for the sub-region</b>		- Long-term planning forecast scenarios	Q3 2015
	- Establish historical coincident peak demand information	<i>IESO</i>		
	- Establish historical weather correction, median and extreme conditions	<i>IESO</i>		
	- Establish gross peak demand forecast	<i>LDCs</i>		
	- Establish existing, committed and potential DG	<i>IESO</i>		
	- Establish near- and long-term conservation forecast based on LDC CDM plans and LTEP target	<i>IESO</i>		
	- Develop planning forecast scenarios - including the impacts of CDM, DG and extreme weather conditions	<i>IESO</i>		
3	<b>Provide information on load transfer capabilities under normal and emergency conditions</b>	<i>LDCs</i>	- Load transfer capabilities under normal and emergency conditions	Q3 2015
4	<b>Provide and review relevant community plans, if applicable</b>	<i>LDCs First Nations and IESO</i>	- Relevant community plans	Q3 2015
5	<b>Complete system studies to identify needs</b> - Obtain PSS/E base case - Include bulk system assumptions as identified in Key Assumptions - Apply reliability criteria as defined in ORTAC to demand forecast scenarios - Confirm and refine the need(s) and timing/load levels	<i>IESO, Hydro One Transmission</i>	- Summary of needs based on demand forecast scenarios for the 20-year planning horizon	Q4 2015
6	<b>Develop Options and Alternatives</b>		- Develop flexible planning options for forecast scenarios	Q1 2016
	Identify solutions requiring immediate implementation and prepare hand-off letters to responsible parties (if applicable)	<i>IESO</i>		
	Develop conservation options	<i>IESO and LDCs</i>		
	Develop local generation options	<i>IESO and LDCs</i>		
	Develop transmission and/or distribution options including maximizing existing infrastructure capability	<i>IESO, Hydro One Transmission and LDCs</i>		
	Develop options involving other electricity initiatives (e.g., smart grid, storage)	<i>IESO/ LDCs with support as needed</i>		
	Develop portfolios of integrated alternatives	<i>All</i>		

	Technical comparison and evaluation	<i>All</i>		
<b>7</b>	<b>Plan and Undertake Community &amp; Stakeholder Engagement</b>		<ul style="list-style-type: none"> <li>- Community and Stakeholder Engagement Plan</li> <li>- Input from local communities, First Nation communities, and Métis Nation of Ontario</li> </ul>	
	- Establish engagement subcommittee of the Working Group	<i>All</i>		Q3 2015
	- Early engagement with local municipalities and First Nation communities within study area, First Nation communities who may have an interest in the study area, and the Métis Nation of Ontario	<i>All</i>		Q3- Q4 2015
	- Establish Local Advisory Committee and develop broader community engagement plan with LAC input	<i>All</i>		Q4 2015
	- Develop communications materials	<i>All</i>		Q1-Q2 2016
	- Undertake community and stakeholder engagement	<i>All</i>		
	- Summarize input and incorporate feedback	<i>All</i>		
<b>8</b>	<b>Develop long-term recommendations and implementation plan based on community and stakeholder input</b>	<i>IESO</i>	<ul style="list-style-type: none"> <li>- Implementation plan</li> <li>- Monitoring activities and identification of decision triggers</li> <li>- Hand-off letters</li> <li>- Procedures for annual review</li> </ul>	Q3 2016
<b>9</b>	<b>Prepare the IRRP report detailing the recommended near, medium and long-term plan for approval by all parties</b>	<i>IESO</i>	<ul style="list-style-type: none"> <li>- IRRP report</li> </ul>	Q4 2016

**Regional Infrastructure Planning – Scope for Aylmer-Tillsonburg Sub-Region  
2015–07–13**

**1. Needs Identified during Needs Assessment**

The primary supply to the Town of Aylmer and Town of Tillsonburg is from a single-circuit 115 kV line, W8T, emanating from Buchanan TS, a distance of about 57 km. Two transformer stations, namely Aylmer TS (15 MVA) and Tillsonburg TS (83 MVA), are connected to this radial circuit and they step the 115 kV transmission voltage level down to the lower distribution voltages for serving customers in the area. Based on the latest load forecast prepared as part of the London Area Needs Assessment (NA) in 2014, the supply capability of W8T is expected to be exceeded in the medium term (2019 – 2023). Additionally, inadequate voltages on this circuit will worsen with load growth. Further, loss of one of the two transformers at Aylmer TS and Tillsonburg TS would result in overloading the remaining transformer.

There are also two existing renewable generators directly connected to this 115 kV system. Currently, ability to connect additional generation sources is restricted due to the thermal constraint on W8T. There is a need to address the supply capacity limitations of the 115 kV transmission system to adequately supply the load in this area.

A schematic diagram of the existing facilities is provided in Figure 1.

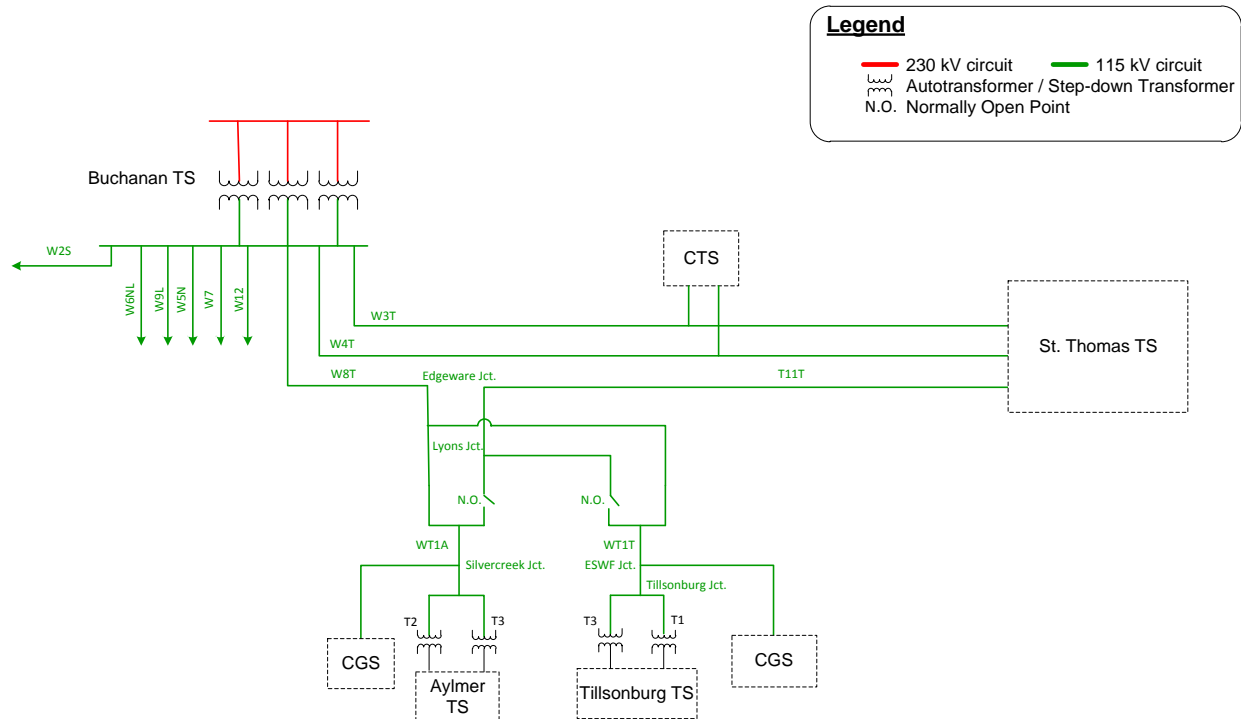

**Figure 1 – Schematic diagram of the existing facilities in Aylmer-Tillsonburg sub-region**

## 2. Alymer-Tillsonburg Sub-region Study Scope

The scope of this study is to develop alternatives to address

1. Supply capability limitation (590A) of 115 kV transmission line (W8T) over the study period
2. Supply capability limitation of Transformer Stations capacity at Alymer TS (15 MVA) and Tillsonburg TS (83 MVA),

As identified in the Scoping Assessment, Hydro One Transmission will initiate and undertake the wires planning work and along with the LDCs within this sub-region to address the above needs. The wires planning will review factors such as:

- the load forecast used in the IRRP and/or NA,
- transmission and distribution system capability along with any other relevant updates with respect to local plans,
- CDM, renewable and non-renewable generation development and
- other electricity system and local drivers that may impact the needs and alternatives under consideration.

## 3. Study Team

The study team will consist of planning representative/s from the following organizations:

- Hydro One Transmission
- IESO
- Erie Thames Power Lines
- Tillsonburg Hydro
- Hydro One Distribution

#### 4. Activities, Primary Accountability and Timeline for Wires Planning

<b>Activity</b>	<b>Primary Accountability</b>	<b>Timeline</b>
Organize and lead study team	Hydro One (Transmission)	Q3 2015
Trigger start of wires planning	Hydro One (Transmission)	Day 0 - 30
Review and reaffirm load forecast	LDCs	
Review and reaffirm CDM and DG for study period	IESO	
Provide any relevant distribution load transfer capabilities under normal and emergency conditions	LDCs	
Perform relevant system studies to identify supply capabilities	Hydro One (Transmission)	Day 31-90
Review and reaffirm regional needs	Study Team	
Generate alternatives to address needs.	Study Team	Day 91-150
Compare and evaluate alternatives <ul style="list-style-type: none"> <li>• TX alternatives</li> <li>• DX alternatives (in lieu of TX alternatives)</li> <li>• Relevant DX investments</li> </ul>	Study Team	
Recommend preferred alternative(s)	Study Team	
Complete Study Report	Hydro One (Transmission)	Day 150-180

#### 5. Deliverable

The deliverable will be a report that summarizes the additional planning assessments and analysis, identifies the potential transmission and/or distribution options and their associated costs, and recommends the preferred overall approach to address the two needs above. The report will ultimately form part of the Regional Infrastructure Plan for the London Area and could be used to support transmission and/or regulatory applications.