

---

# Greater Toronto Area West (GTA West)

## Integrated Regional Resource Plan

Appendices

# Table of Contents

<b>Appendix A – Overview of the Regional Planning Process</b>	<b>3</b>
<b>Appendix B – Demand Forecast</b>	<b>6</b>
B.1 Method for Accounting for Weather Impact on Demand	6
B.2 Alectra Utilities Forecast Methodology	7
End-Use Analysis Using the Latest Information	8
Weather Correction	8
Other Factors	8
CDM	9
DG	9
Electrification of Transportation	9
Past System Peak Performance and Trend Analysis	9
Conclusion	9
B.3 Hydro One Distribution Forecast Methodology	9
B.4 Halton Hills Hydro Distribution Forecast Methodology	11
Pleasant TS Load Forecast	11
Halton TS Load Forecast	11
Halton Hills MTS	12
B.5 Oakville Hydro Distribution Forecast Methodology	12
B.6 Burlington Hydro Distribution Forecast Methodology	13
B.7 Milton Hydro Distribution Forecast Methodology	14
B.8 Conservation and Demand Management Assumptions	15
B.8.1. Estimated Savings from Building Codes and Equipment Standards	15
B.8.2. Estimated Savings from Energy Efficiency Programs	16
B.8.3. Total Energy Efficiency Savings and Impact on the Planning Forecast	16
B.9 Installed Distributed Generation and Contribution Factor Assumptions	18
B.10 Final Peak Forecast by Station	19
<b>Appendix C – GTA West IRRP Technical Study</b>	<b>21</b>

C.1 Description of Study Area	21
C.2 Scenarios Assessed	22
C.2.1 Load Forecast	23
C.2.2 Local Generation Assumptions	23
C.2.3 Major Interface Flows	24
C.3 System Topology	25
C.3.1 Monitored Circuits and Sections	25
C.3.2 Special Protection Systems	29
C.4 Credible Planning Events and Criteria	30
C.4.1 Studied Contingencies	30
C.4.2 Planning Criteria	34
C.5 Study Result Findings	36
C.5.1 Scenario A1 Findings	36
C.5.1.1 H29/H30 Supply Capacity Need	36
C.5.1.2 T38B/T39B Load Security Need	36
C.5.2 Scenario A2 Findings	37
C.5.2.1 R19TH/R21TH Supply Capacity Need	37
C.5.3 Scenario B Findings	37
C.5.3.1 T38B/T39B Supply Capacity Need	37
C.5.4 Scenario C Findings	38
C.6 Step Down Station Capacity Findings	38
<b>Appendix D – Hourly Need Characterization</b>	<b>39</b>
D.1 T38B/T39B N-G-1 Thermal Need	39
D.2 R19TH/R21TH N-1-1 Thermal Need	40
D.3 T38B/T39B N-2 Load Security	41
<b>Appendix E – Economic Assumptions</b>	<b>42</b>

# Appendix A – Overview of the Regional Planning Process

In Ontario, meeting the electricity needs of customers at a regional level is achieved through regional planning. This comprehensive process starts with an assessment of the needs of a region—defined by common electricity supply infrastructure—over the near, medium, and long term and results in the development of a plan to ensure cost-effective, reliable electricity supply. Regional plans consider the existing electricity infrastructure in an area, forecast growth and customer reliability, evaluate options for addressing needs, and recommend actions.

Regional planning has been conducted on an as-needed basis in Ontario for many years. Most recently, planning activities to address regional electricity needs were the responsibility of the former Ontario Power Authority (OPA), now the Independent Electricity System Operator (IESO), which conducted joint regional planning studies with distributors, transmitters, the IESO and other stakeholders in regions where a need for coordinated regional planning had been identified.

In the fall of 2012, the Ontario Energy Board (OEB) convened a Planning Process Working Group (PPWG) to develop a more structured, transparent, and systematic regional planning process. This group was composed of electricity agencies, utilities, and other stakeholders. In May 2013, the PPWG released its report to the OEB (PPWG Report), setting out the new regional planning process. Twenty one electricity planning regions were identified in the PPWG Report, and a phased schedule for completion of regional plans was outlined.<sup>1</sup> The OEB endorsed the PPWG Report and formalized the process timelines through changes to the Transmission System Code and Distribution System Code in August 2013, and to the former OPA's licence in October 2013. The licence changes required the OPA to lead two out of four phases of regional planning. After the merger of the IESO and the OPA on January 1, 2015, the regional planning roles identified in the OPA's licence became the responsibility of the IESO.

---

<sup>1</sup> [http://www.ontarioenergyboard.ca/OEB/\\_Documents/EB-2011-0043/PPWG\\_Regional\\_Planning\\_Report\\_to\\_the\\_Board\\_App.pdf](http://www.ontarioenergyboard.ca/OEB/_Documents/EB-2011-0043/PPWG_Regional_Planning_Report_to_the_Board_App.pdf)

The regional planning process begins with a Needs Assessment process performed by the transmitter, which determines whether there are needs that should be considered for regional coordination. If further consideration of the needs is required, the IESO conducts a Scoping Assessment to determine what type of planning should be carried out for a region. A Scoping Assessment explores the need for a comprehensive IRRP, which considers conservation, generation, transmission, and distribution solutions, or whether a more limited “wires” solution is the preferable option, in which case a transmission- and distribution-focused Regional Infrastructure Plan (“RIP”) can be undertaken instead. There may also be regions where infrastructure investments do not require regional coordination and can be planned directly by the distributor and transmitter outside of the regional planning process. At the conclusion of the Scoping Assessment, the IESO produces a report that includes the results of the needs assessment process and a preliminary terms of reference. If an IRRP is the identified outcome, the IESO is required to complete the IRRP within 18 months. If a RIP is the identified outcome, the transmitter takes the lead and has six months to complete it. Both RIPs and IRRPs are to be updated at least every five years. The draft Scoping Assessment Outcome Report is posted to the IESO’s website for a two-week public comment period prior to finalization.

The final Needs Assessment Reports, Scoping Assessment Outcome Reports, IRRPs and RIPs are posted on the IESO’s and the relevant transmitter’s web sites, and may be referenced and submitted to the OEB as supporting evidence in rate or “Leave to Construct” applications for specific infrastructure investments. These documents are also useful for municipalities, First Nation communities and Métis community councils for planning, and for conservation and energy management purposes. They are also a useful source of information for individual large customers that may be involved in the region, and for other parties seeking an understanding of local electricity growth, CDM and infrastructure requirements. Regional planning is not the only type of electricity planning undertaken in Ontario. As shown in Figure 1, three levels of electricity system planning are carried out in Ontario:

- Bulk system planning
- Regional system planning
- Distribution system planning

Planning at the bulk system level typically considers the 230 kV and 500 kV network and examines province-wide system issues. In addition to considering major transmission facilities or “wires”, bulk system planning assesses the resources needed to adequately supply the province. Distribution planning, which is carried out by local distribution companies (“LDCs”), considers specific investments in an LDC’s territory at distribution-level voltages.

Regional planning can overlap with bulk system planning and with the distribution planning of LDCs. For example, overlaps can occur at interface points where there may be regional resource options to address a bulk system issue or when a distribution solution addresses the needs of the broader local area or region. As a result, it is important for regional planning to be coordinated with both bulk and distribution system planning, as it is the link between all levels of planning.

**Figure 1 | Levels of Electricity System Planning**

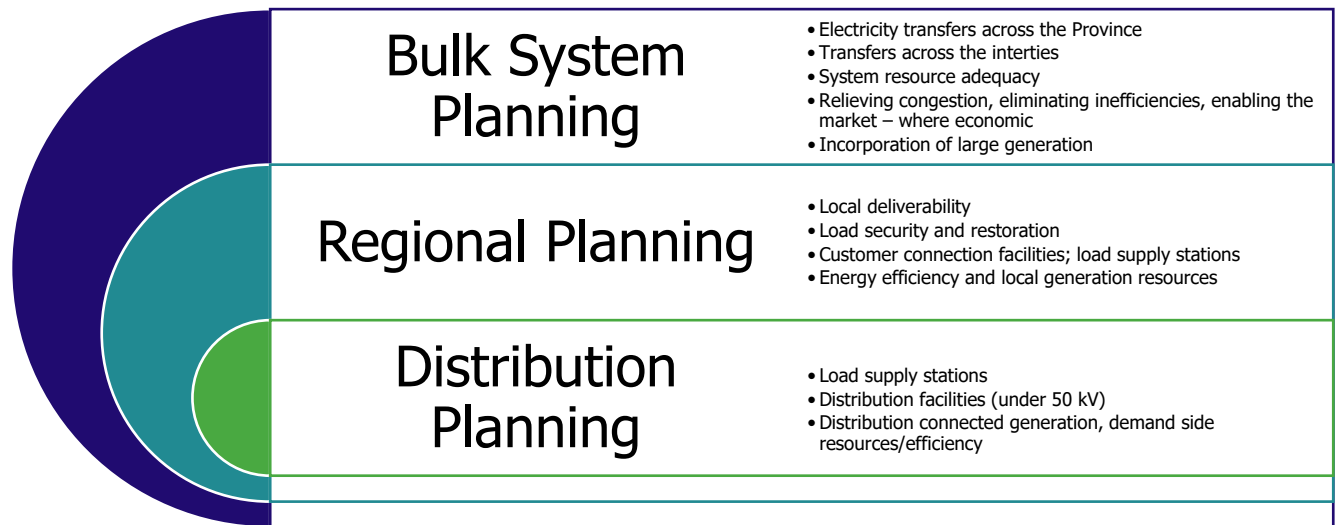

By recognizing the linkages with bulk and distribution system planning, and coordinating the multiple needs identified within a region over the long term, the regional planning process provides a comprehensive assessment of a region’s electricity needs. Regional planning aligns near- and long-term solutions and puts specific investments and recommendations coming out of the plan into perspective. Furthermore, in avoiding piecemeal planning and asset duplication, regional planning optimizes ratepayer interests, allowing them to be represented along with the interests of LDC ratepayers, and individual large customers. IRRPs evaluate the multiple options that are available to meet the needs, including conservation, generation, and “wires” solutions. Regional plans also provide greater transparency through engagement in the planning process, and by making plans available to the public

## Appendix B – Demand Forecast

Appendix B describes the methodologies used to develop the demand forecast (peak and duration) for the GTA West IRRP studies. Forward-looking estimates of electricity demand were provided by each of the participating LDCs and informed by the forecast base year and starting point provided by the IESO. The sections that follow describe the weather correction methodology, the approaches and methods used by each LDC to forecast demand in their respective service area, and the conservation and DG assumptions.

### B.1 Method for Accounting for Weather Impact on Demand

Weather has a large influence on the demand for electricity, so to develop a standardized starting point for the forecast, the historic electricity demand information is weather-normalized. This section details the weather-normalization process used to establish the starting point for regional demand forecasts.

First, the historical loads were adjusted to reflect the median peak weather conditions for each transformer station in the area for the forecast base year (i.e. 2018 for the GTA West IRRP). Median peak refers to what peak demand would be expected if the most likely, or 50th percentile, weather conditions were observed. This means that in any given year there is an estimated 50% chance of exceeding this peak, and a 50% chance of not meeting this peak. The methodological steps are described in Figure 2.

**Figure 2 | Method for Determining the Weather Normalized Peak (Illustrative)**

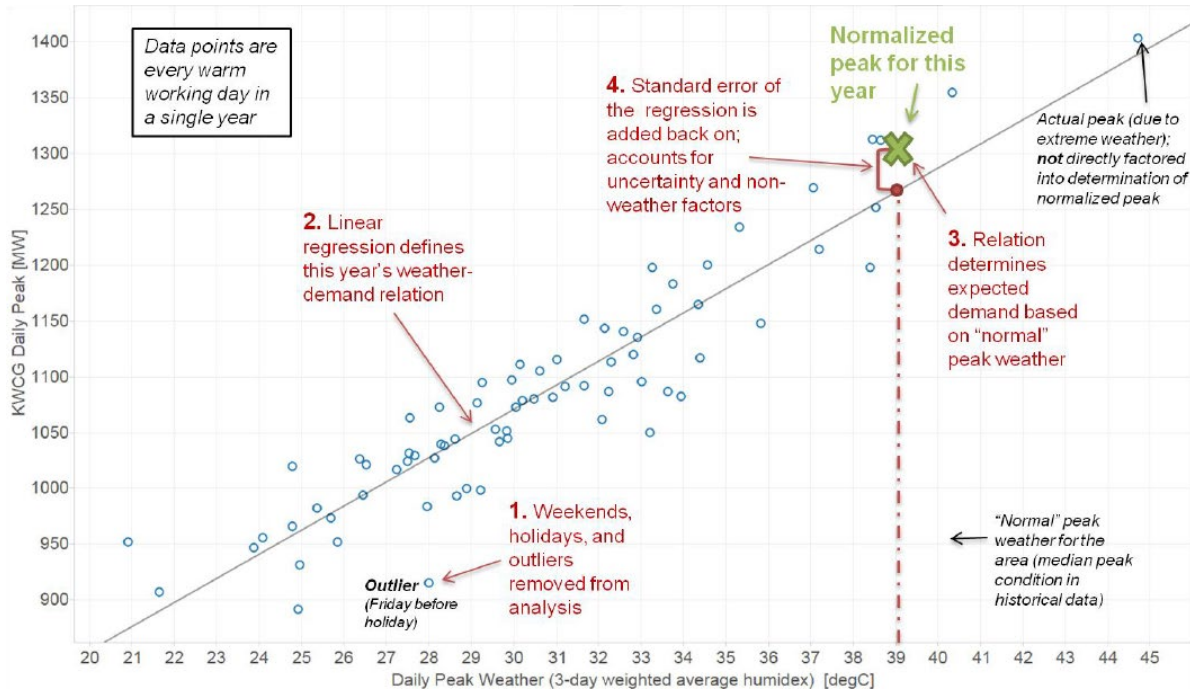

The 2018 median weather peak on a station and LDC load basis was provided to each LDC. This data was used as a start point from which to develop 20-year demand forecasts, using the LDCs preferred methodology (described in the next sections).

Once the 20-year horizon, median peak demand forecasts were returned to the IESO, the normal weather forecast was adjusted to reflect the impact of extreme weather conditions on electricity demand. The studies used to assess the adequacy and reliability of the electric power system generally require studies to be based on extreme weather demand, or, expected demand under the hottest weather conditions that can be reasonably expected to occur. Peaks that occur during extreme weather (e.g. summer heat waves in southern Ontario) are generally when the electricity system infrastructure is most stressed.

## B.2 Alectra Utilities Forecast Methodology

The Alectra Utilities long-term load forecast provides an indication as to where and how much the load increases are occurring. An increase in the peak demand is normally the biggest factor in driving the requirement for reinforcement of the system. Alectra Utilities performs a load forecasting exercise annually.

Alectra Utilities performed a combination of two methods of forecasting to determine the long-term system capacity adequacy assessment:

- End-use analysis using the latest information available from municipal report; and
- Past system peak performance and trend (statistical) analysis.



## End-Use Analysis Using the Latest Information

Alectra Utilities reviewed economic development and outlook for different regions that include Ontario Government development, population growth and job growth projections, municipal economic analysis report, past housing completion statistics and future housing projection, ICI building activities and news from media.

**Population Growth:** Historical annual population growth was obtained from Regional Annual Economic and Municipal Development Review Reports. Long-term annual population projections were obtained from provincial and municipal official plan reports published by Ontario government, and regional/municipal government.

**Employment Growth:** Historical employment and economic growth statistics reports published by Provincial and Municipal governments were used to extract the historic economic development and growth rates. Employment growth and structure projection were used to develop long-term employment forecast potentially categorized by the sector, industry and service types.

**Housing Activities:** Number of housing completions, mix of housing completions, vacancy rate and building permit activities in the Region and Municipal boundaries and residential developments plan were reviewed for long-term capacity need forecast. Plans of subdivision and condominiums were obtained and analyzed to develop the long-term load forecast.

**ICI Building Activity:** Industrial and Commercial development rate, commercial vacancy rate, industrial sale prices per square feet, total ICI construction and commercial/industrial building permits were obtained and compiled to develop the long-term load forecast for the region.

## Weather Correction

Alectra used weighted 3-day moving average temperature to correlate the peak demand and weather. Peak demand weather normalization is the process for estimating what peak demand would have occurred in a given time period if the weather had been normal (1 in 2). The weather normalized peak demand was used as the starting point for the forecast. Alectra used "1-in-10" (extreme) weather scenario for system planning purposes to contemplate the impact of extreme weather (i.e., high temperatures) on peak demand.<sup>2</sup>

## Other Factors

The other contributing factors to long-term load projections were CDM, DG contribution and other government incentives and programs (i.e., Global Adjustment), emerging industrial technologies (i.e., Microgrid, battery storage, combined heat & power, etc.), newly introduced load types (i.e., electric vehicles, fleets) that were reviewed and assessed in load forecast procedure.

---

<sup>2</sup> The 1 in 2 forecast was used to develop the gross IRRP median weather forecast. This was subsequently adjusted for extreme weather according to the methodology in Appendix B.1.

## **CDM**

Alectra Utilities' load forecast was performed using current year's actual peak (weather normalized) as starting point. The impact of CDM programs in the previous years is reflected in the actual peak. The CDM for future years was considered in the forecast.<sup>3</sup>

## **DG**

Alectra Utilities' forecast considered the existing DG and DG connections forecasted over the horizon period.

## **Electrification of Transportation**

Alectra Utilities continues to monitor the uptake of electric vehicles (EVs) and projects related to electrification of transportation to better understand and determine the impact on local electricity needs. Alectra Utilities used the available information on EV adoption and evaluates the impact of the EVs at the peak.

## **Past System Peak Performance and Trend Analysis**

The trend analysis was performed to forecast the system peak from historical peak demand results. The purpose of the trend analysis is to compare the results with end-use method to obtain more realistic long-term load projections considering the historical demand peak.

## **Conclusion**

There is a level of uncertainty with respect to any forecasting exercise. Any major unexpected changes to assumptions, economic pressure or crisis events, government directives and other social/economic/political events that can impose changes and that were not contemplated at the time of forecasting will be reviewed and the forecast will be adjusted annually accordingly to reflect the changes.

## **B.3 Hydro One Distribution Forecast Methodology**

Hydro One Distribution services the areas of GTA West region that are not serviced by other LDCs. It supplies power through Pleasant TS included in the study area.

Hydro One Distribution used both econometric and end-use forecasting to develop the load forecast provided to the IESO. A baseline forecast (MW station peak in the base year) was developed, taking into account such factors as normal operating conditions, coincident peak loading, and extreme weather conditions.

---

<sup>3</sup> The "current year" for the purpose of this IRRP forecast was 2018. Note that, while the impact of existing/past CDM programs were included in the starting point, future CDM program impact was forecasted by the IESO.

For the GTA West IRRP forecast, Hydro One Distribution used the weather corrected peak demand levels for the station serving Hydro One customers. From the established baseline year, a growth rate (%) was applied to station demand level to provide forecast values within the study timeframe.

Assumptions included in the growth rate can be related to such factors as: Ontario GDP growth rate, housing statistics, the intensification of urban developments (i.e., MW/sq.ft); and electrification trends (e.g., more vehicles switching from gas to electrical vehicles).

Where possible, detailed information about load growth, based on local knowledge and or municipal/provincial plans, was used to augment the forecast values within the study period.

## B.4 Halton Hills Hydro Distribution Forecast Methodology

### Pleasant TS Load Forecast

1. Historical peak MW are based on HHHI feeder data and are not corrected for weather normalization (Historical Weather-Corrected Gross Station Demand at Coincidental Regional Peak Hours (MW)).
2. Planned development is based on known development in Georgetown and rural areas supplied by these feeders. Anticipated load years are estimated based on status of development.
3. There are no plans HHHI is aware of for GO Transit rail electrification in Halton Hills and as such is not impacting our load forecast.
4. At the time of this load forecast HHHI is unaware of any proposed behind-the-meter generation projects within the load forecast area.
5. HHHI has estimated as annual growth factor of 0.5% from 2019 to 2038. The growth factor shown in the chart per year is based on the 2018 peak MW and is calculated as  $64.42\text{MW} * 0.005 = 0.322\text{MW}$  in 2019. Each subsequent year is based on the prior year. Thus 2020's annual growth is based on 2019's forecasted peak.
6. Weather factors beyond IESO information have not been considered in this forecast.

### Halton TS Load Forecast

1. Historical peak MW are based on HHHI feeder data and are not corrected for weather normalization (Historical Weather-Corrected Gross Station Demand at Coincidental Regional Peak Hours (MW)).
2. Planned development is based on known development in Georgetown and rural areas supplied by these feeders. Anticipated load years are estimated based on status of development.
3. There are no plans HHHI is aware of for GO Transit rail electrification in Halton Hills and as such is not impacting our load forecast.
4. At the time of this load forecast HHHI is unaware of any proposed behind-the-meter generation projects within the load forecast area.
5. HHHI has estimated as annual growth factor of 0.2% from 2019 to 2038. The growth factor shown in the chart per year is based on the 2018 peak MW and is calculated as  $43.34\text{MW} * 0.002 = 0.087\text{MW}$  in 2019. Each subsequent year is based on the prior year. Thus 2020's annual growth is based on 2019's forecasted peak.
6. Weather factors beyond IESO information have not been considered in this forecast.
7. HHHI is planning to put most of the new load on our 27.6kV system onto Halton Hills MTS.

## Halton Hills MTS

1. There is no historical peak data for Halton Hills HTS #1. This is the first load forecast being submitted to the IESO for this Halton Hills MTS #1.
2. Planned development is based on known development in Georgetown and rural areas supplied by these feeders. Anticipated load years are estimated based on status of development.
3. There are no plans HHHI is aware of for GO Transit rail electrification in Halton Hills and as such is not impacting our load forecast.
4. At the time of this load forecast HHHI is unaware of any proposed behind-the-meter generation projects within the load forecast area.
5. HHHI has estimated an annual growth factor of 0.5% from 2019 to 2038.
6. Weather factors beyond IESO information have not been considered in this forecast.

## B.5 Oakville Hydro Distribution Forecast Methodology

Oakville Hydro bases load forecasting on the most recent Best Planning Estimates of Population, Occupied Dwelling Units and Employment report issued by the Region of Halton. Residential growth is derived by the forecasted estimates of occupied dwellings. Non-residential growth (commercial, retail, industrial and institutional) is derived by the employment figures contained within the planning report.

The municipality (the Town of Oakville) is also consulted to determine the geographic areas of new development, as well as any specific information from development planning and economic development avenues. The planning figures are converted to load in kW using variables according to density, load per occupied dwelling, dwelling type, load per employee, and load per area for non-residential developments, etc. The load forecast is adjusted based on recent historical trends and any known large load (e.g. a Hospital or Data Centre).

Based on the geographic area of the forecasted load, or known future loads, the load estimate is assigned to the area of the respective TSs' service area:

- Northwest – Palermo TS
- North Central – Glenorchy MTS
- Northeast – Trafalgar TS
- Southwest – Bronte TS
- Southeast – Oakville TS

## B.6 Burlington Hydro Distribution Forecast Methodology

Burlington Hydro owns and operates the electricity distribution system which serves the City of Burlington. BHI's total service area is 188 square km, located in Halton Region between the north shore of Lake Ontario and the Niagara Escarpment. It supplies power through five transformer stations: Tremaine TS, Palermo TS, Burlington TS, Bronte TS and Cumberland TS.

BHI currently serves approximately 68,000 customers. The City of Burlington is an area of moderate economic growth, with a fixed urban boundary and a limited supply of land designated for warehouse, manufacturing, and office use. The Ontario government's long-term Places to Grow infrastructure plan has provided an expansion impetus, envisaging the City of Burlington as one of the 25 "Urban Growth Centres" in the Golden Horseshoe. However, the availability of land for residential and commercial expansion is becoming progressively limited as the City of Burlington expands towards the boundary imposed by the Greenbelt, which occupies a large part of its service area. The City of Burlington has responded to the government directive by intensifying vertical development and refurbishment in the downtown core.

BHI's overall load forecast was based on peak demand growth of 1% per annum from 2019 - 2029, Overall growth of 1.25% per annum was estimated for 2030 to 2037. These figures considered historical growth and available population growth forecasts from the City of Burlington and Region of Halton.

The starting point for the load forecast was the coincident peak demand data by TS for the most recent year of actuals (2018), which BHI adjusted to account for normal operating conditions. A growth rate (%) was applied to the most recent year of actuals to provide forecast values, at each station, within the study time frame; with the exception of the TSs already operating at capacity.

## B.7 Milton Hydro Distribution Forecast Methodology

The Town of Milton is one of the fastest growing communities in Canada and encompasses a land area of 366.61 square km. Total Census Population - 110,128 (2016) represents a change of 30.5% from 2011. This compares to the provincial average of 4.6% and national average of 5.0%. With an approximate population of 143,000 in 2021, Milton is expected to grow to approximately 228,000 by 2031 under the Halton Region's Best Planning Estimates.

Milton Hydro's forecast methodology combines the past system peak performance trend with the residential as well as the industrial and commercial projected load growth. The town's planned population growth is expected to produce a significant demand on Milton Hydro's supply capacity.

Milton is supplied by the following:

<b>Owner</b>	<b>TS</b>	<b>Feeders</b>
Hydro One	Halton TS	9
Hydro One	Palermo TS	2
Hydro One	Tremaine TS	4
Hydro One	Fergus TS	1
Oakville Hydro	Glenorchy MTS	2

"Halton Region's Best Planning Estimates of population, occupied dwelling units and employment, 2011 – 2031"

The Best Planning Estimates is a planning tool used to identify where and when development is expected to take place across the Region. The Best Planning Estimates represent good long-term planning. This tool will assist the Region and the Local Municipalities in planning complete healthy communities including: the establishment of the supply of housing, type of housing and jobs across the Region. The Best Planning Estimates also provide direction in determining the timely provision of both hard infrastructure (roads, water and wastewater) and community infrastructure (schools, community recreation etc.).

The area bounded by 401 south to 407 and Tremaine Road east to 407 will have the greatest load growth expectations due to future load growth.

## B.8 Conservation and Demand Management Assumptions

Energy efficiency measures can reduce the electricity demand and their impact can be separated into the two main categories: Building Codes & Equipment Standards, and Energy Efficiency Programs. The assumptions used for the GTA West IRRP forecast are consistent with the energy efficiency assumptions in the IESO's 2019 Annual Planning Outlook as well as the 2021 – 2024 CDM Framework. The savings for each category were estimated according to the forecast residential, commercial, and industrial gross demand. A top down approach was used to estimate peak demand savings from the provincial level to the Southwest and Toronto IESO zones and then allocated to the GTA West Region. This appendix describes the process and methodology used to estimate energy efficiency savings for the GTA West Region and provides more detail on how the savings for the two categories were developed.

### **B.8.1. Estimated Savings from Building Codes and Equipment Standards**

Ontario building codes and equipment standards set minimum efficiency levels through regulations and are projected to improve and further contribute to demand reduction in the future. To estimate the impact on the region, the associated peak demand savings for codes and standards by sector were estimated for the Southwest and Toronto zones and compared with the gross peak demand forecast for each zone. From this comparison, annual peak reduction percentages were developed for the purpose of allocating the associated savings to each station in the region, as further described below.

Consistent with the gross demand forecast, 2018 was used as the base year. New peak demand savings from codes and standards were estimated from 2019 to 2038. The residential annual peak reduction percentages for each year were applied to the forecast residential peak demand at each station to develop an estimate of peak demand impacts from codes and standards. By 2038, the residential sector in the region is expected to see about 7% peak demand savings through codes and standards. The same is done for the commercial sector, which will see about 4% peak-demand savings through codes and standards by 2038. The sum of the savings associated with the two sectors are the total peak demand impact from codes and standards. It is assumed that there are no savings from codes and standards associated with the industrial sector.



## B.8.2. Estimated Savings from Energy Efficiency Programs

In addition to codes and standards, the delivery of CDM programs reduces electricity demand. The impact of existing and committed CDM programs were analyzed, which include the 2021 – 2024 CDM Framework. A top down approach was used to estimate the peak demand reduction due to the delivery of 2019 and 2020 programs, from the province, to the Southwest and Toronto zones, and finally to the stations in the region. Persistence of the peak demand savings from energy efficiency programs were considered over the forecast period. On September 30, 2020 the IESO received a Ministerial directive to implement a new 2021-2024 CDM Framework starting in January 2021. As this directive was received after the GTA West Region’s load forecast was finalized its impact is not included in the forecast.

Similar to the estimation of peak demand savings from codes and standards, annual peak demand reduction percentages from program savings were developed by sector. The sectoral percentages were derived by comparing the forecasted peak demand savings with the corresponding gross forecasts in Southwest and Toronto zones. They were then applied to the sectoral gross peak forecast of each station in the region. By 2030, the residential sector in the region is expected to see about 0.3% peak demand savings through programs, while commercial sector and industrial sector will see about 3% and 2% peak reduction respectively. Those savings will decay over time as the energy efficiency measures come to the end of their effective useful lives.

## B.8.3. Total Energy Efficiency Savings and Impact on the Planning Forecast

As described in the above sections, peak demand savings were estimated for each sector, and totalled for each station in the region. The analyses were conducted under normal weather conditions and can be adjusted to reflect extreme weather conditions. The resulting forecast savings were applied to gross demand to determine net peak demand for further planning analyses.

**Table 1 | Final IRRP CDM (Codes and Standards + Energy Efficiency) Forecast**

<b>Transformer Station</b>	<b>2019</b>	<b>2020</b>	<b>2021</b>	<b>2022</b>	<b>2023</b>	<b>2024</b>	<b>2025</b>	<b>2026</b>	<b>2027</b>	<b>2028</b>	<b>2029</b>	<b>2030</b>	<b>2031</b>	<b>2032</b>	<b>2033</b>	<b>2034</b>	<b>2035</b>	<b>2036</b>	<b>2037</b>	<b>2038</b>
Bramalea TS	3.8	1.4	4.4	7.8	11.9	14.7	16.5	16.9	17.7	17.9	16.9	15.5	14.6	13.9	12.9	12.8	13.3	13.4	13.6	13.7
Cardiff TS	1.5	0.5	1.7	3.1	4.6	5.7	6.6	6.9	7.4	7.6	7.2	6.5	5.9	5.5	5.0	4.9	5.1	5.1	5.2	5.2
Churchill Meadows TS	1.5	0.5	1.7	3.0	4.6	5.6	6.3	6.3	6.5	6.5	6.0	5.4	5.0	4.6	4.2	4.2	4.3	4.4	4.4	4.5
Cooksville TS	1.5	0.5	1.8	3.1	4.8	6.4	7.6	7.9	8.4	8.6	8.0	7.2	6.6	6.2	5.6	5.5	5.7	5.8	5.9	6.0
Erindale TS	5.9	2.1	6.8	12.1	18.8	23.6	26.9	27.9	29.6	30.2	28.6	26.2	24.0	22.5	20.4	20.2	20.9	21.2	21.8	22.3
Glenorchy MTS #1	0.6	0.2	0.8	1.7	2.9	3.9	4.8	5.2	5.8	6.1	6.3	6.4	6.3	6.3	6.1	6.2	6.5	6.7	6.7	6.8

<b>Transformer Station</b>	<b>2019</b>	<b>2020</b>	<b>2021</b>	<b>2022</b>	<b>2023</b>	<b>2024</b>	<b>2025</b>	<b>2026</b>	<b>2027</b>	<b>2028</b>	<b>2029</b>	<b>2030</b>	<b>2031</b>	<b>2032</b>	<b>2033</b>	<b>2034</b>	<b>2035</b>	<b>2036</b>	<b>2037</b>	<b>2038</b>
Goreway TS	3.2	1.1	3.6	6.4	9.9	12.4	14.1	14.5	15.4	15.7	15.0	14.0	13.3	12.8	12.0	12.0	12.4	12.5	12.6	12.8
Halton TS	2.0	0.8	2.7	4.2	6.3	7.8	8.8	9.2	9.7	9.9	10.0	10.0	9.7	9.5	9.2	9.1	9.2	9.2	9.2	9.3
Halton TS #2	0.0	0.0	0.0	0.6	1.1	1.7	2.2	2.5	2.9	3.3	3.6	3.8	3.9	4.0	4.0	4.1	4.3	4.5	4.7	4.9
Halton Hills MTS	0.0	0.0	0.1	0.1	0.2	0.3	0.5	0.7	0.9	1.1	1.3	1.5	1.8	2.1	2.4	2.8	2.9	2.9	2.9	3.0
Jim Yarrow MTS	1.6	0.6	2.0	3.5	5.6	7.2	8.2	8.5	9.0	9.1	8.8	8.2	7.8	7.5	7.0	7.0	7.3	7.4	7.5	7.6
Kleinburg TS	4.1	5.6	5.7	6.4	7.1	7.5	8.1	8.6	9.0	9.1	9.4	9.8	10.4	11.0	11.4	11.6	11.8	11.8	11.6	11.6
Lorne Park TS	1.1	0.4	1.4	2.5	3.9	4.9	5.4	5.4	5.6	5.6	5.2	4.7	4.3	4.0	3.6	3.6	3.7	3.8	3.8	3.9
Meadowvale TS	1.5	0.5	1.6	2.9	4.6	5.9	6.9	7.2	7.7	7.7	7.5	7.3	6.8	6.5	6.0	5.9	6.1	6.2	6.3	6.4
Oakville TS #2	1.9	0.7	2.1	3.7	5.7	7.0	7.8	8.0	8.3	8.4	7.9	7.3	6.9	6.6	6.1	6.1	6.3	6.3	6.3	6.4
Palermo TS	1.4	0.5	1.5	2.6	3.9	4.9	5.5	5.7	6.0	6.1	6.0	6.0	5.7	5.6	5.3	5.3	5.4	5.4	5.4	5.5
Pleasant TS	4.4	1.7	5.2	9.2	14.3	18.1	20.7	21.8	23.4	24.3	24.1	23.5	23.1	23.0	22.5	22.7	23.6	24.0	24.3	24.6
Tomken TS	3.8	1.3	4.5	7.8	11.9	14.6	16.2	16.3	16.9	16.8	15.5	14.0	13.2	12.6	11.7	11.9	12.6	13.1	13.3	13.4
Trafalgar TS	1.1	0.4	1.1	2.0	3.1	3.9	4.4	4.5	4.7	4.8	4.7	4.7	4.5	4.4	4.1	4.1	4.2	4.2	4.2	4.3
Tremaine TS	1.2	0.5	1.6	2.8	4.4	5.8	6.7	7.2	7.7	8.1	8.4	8.8	8.8	9.1	9.2	9.5	9.9	10.0	10.1	10.5

## B.9 Installed Distributed Generation and Contribution Factor Assumptions

**Table 2 | DG Contribution Factors**

	Jan	Feb	Mar	Apr	May	Jun	Jul	Aug	Sep	Oct	Nov	Dec
Solar capacity contribution	0.0%	0.0%	0.2%	1.2%	2.7%	13.8%	13.8%	13.8%	8.5%	0.0%	0.0%	0.0%
Wind capacity contribution	37.8%	37.8%	33.6%	34.6%	22.7%	13.7%	13.7%	13.7%	14.8%	30.2%	36.5%	37.8%

**Table 3 | Installed DG by Station**

Station	Installed Solar (MW)	Assumed Solar Output (MW)	Installed Gas (MW)	Assumed Gas Output (MW)	Total Assumed DG Output (MW)
Bramalea TS		8.3	1.0	100.3	101.3
Cardiff TS		0.1	0.0	0.0	0.0
Churchill Meadows TS		2.8	0.4	0.0	0.4
Cooksville TS		0.1	0.0	0.0	0.0
Erindale TS		7.4	0.9	5.6	6.5
Glenorchy MTS #1		1.2	0.1	0.0	0.1
Goreway TS		11.2	1.4	0.0	1.4
Halton TS		2.8	0.3	0.0	0.3
Jim Yarrow MTS		6.5	0.8	0.0	0.8
Kleinburg TS		3.1	0.4	3.2	3.6
Lorne Park TS		0.7	0.1	0.0	0.1
Meadowvale TS		2.4	0.3	0.0	0.3
Oakville TS #2		1.7	0.2	0.0	0.2
Palermo TS		0.0	0.0	2.1	2.1
Pleasant TS		18.7	2.3	0.0	2.3
Tomken TS		7.6	1.0	0.0	1.0
Trafalgar TS		0.0	0.0	0.0	0.0
Tremaine TS		1.7	0.2	0.0	0.2

\*This large gas generator was accounted for in the LDC gross forecast. Therefore, it was not included in the IESO DG forecast.

## B.10 Final Peak Forecast by Station

After taking the median weather forecast provided by LDCs and applying the CDM and DG assumptions above, forecasts were adjusted to extreme weather. The final peak demand forecasts, by station, are provided below:

**Table 4 | Peak Demand Forecast by Station**

<b>Transformer Station</b>	<b>2019</b>	<b>2020</b>	<b>2021</b>	<b>2022</b>	<b>2023</b>	<b>2024</b>	<b>2025</b>	<b>2026</b>	<b>2027</b>	<b>2028</b>	<b>2029</b>	<b>2030</b>	<b>2031</b>	<b>2032</b>	<b>2033</b>	<b>2034</b>	<b>2035</b>	<b>2036</b>	<b>2037</b>	<b>2038</b>
Bramalea TS	265	274	274	273	271	270	270	272	273	275	279	283	286	289	293	296	298	300	302	304
Cardiff TS	97	103	102	101	100	99	102	106	109	113	118	119	121	122	123	124	124	125	125	125
Churchill Meadows TS	103	109	108	107	105	104	104	104	103	104	105	106	108	109	110	112	113	113	114	115
Cooksville TS	100	106	105	104	106	113	120	124	128	132	133	135	137	139	140	142	143	144	145	146
Erindale TS	393	421	404	409	412	416	426	437	454	467	483	497	504	510	517	523	527	532	543	555
Glenorchy MTS #1	49	58	66	74	81	88	95	101	107	111	115	118	121	125	128	131	135	138	138	138
Goreway TS	221	226	227	228	229	230	232	235	238	241	245	249	252	255	258	260	263	265	267	269
Halton TS	186	197	217	198	196	195	194	194	193	193	193	193	194	194	194	195	195	195	195	195
Halton TS #2	0	0	0	28	34	40	46	52	58	64	70	76	82	87	91	95	100	104	108	112
Halton Hills MTS	2	3	6	6	6	9	13	16	19	22	25	28	32	37	43	50	50	50	50	50
Jim Yarrow MTS	121	125	129	134	137	142	143	145	147	149	152	154	156	158	161	162	164	165	167	169
Kleinburg TS	143	144	145	146	146	147	147	147	148	149	149	169	169	169	169	169	170	171	172	172
Lorne Park TS	73	78	81	84	87	86	85	85	85	85	86	87	89	90	91	92	93	94	94	95
Meadowvale TS	105	111	110	109	111	114	117	121	125	125	126	127	129	130	132	133	135	136	137	138
Oakville TS #2	140	143	141	140	138	137	136	136	135	135	136	137	137	138	139	139	139	140	140	140

<b>Transformer Station</b>	<b>2019</b>	<b>2020</b>	<b>2021</b>	<b>2022</b>	<b>2023</b>	<b>2024</b>	<b>2025</b>	<b>2026</b>	<b>2027</b>	<b>2028</b>	<b>2029</b>	<b>2030</b>	<b>2031</b>	<b>2032</b>	<b>2033</b>	<b>2034</b>	<b>2035</b>	<b>2036</b>	<b>2037</b>	<b>2038</b>
Palermo TS	114	112	114	113	112	112	111	111	111	114	114	114	115	116	116	117	117	117	118	118
Pleasant TS	362	372	382	390	397	401	404	412	418	423	431	439	444	450	456	461	468	474	478	483
Tomken TS	255	270	268	264	260	258	256	256	255	256	259	262	273	283	294	304	314	324	326	329
Trafalgar TS	90	91	90	89	88	87	87	86	86	86	86	86	86	87	87	87	87	87	87	87
Tremaine TS	125	133	140	147	154	161	163	165	167	170	173	176	180	185	190	196	202	207	208	214

# Appendix C – GTA West IRRP Technical Study

## C.1 Description of Study Area

The study area for the GTA West Region primarily includes the 230 kV circuits and stations served from Burlington TS to Richview TS. These also include circuits and stations that stem from this Burlington TS to Richview TS path; namely the T38B/T39B pocket, the R19TH/R21TH pocket that serves Hurontario SS and the circuits connecting Hurontario SS to Claireville TS, and the Cookville Tap pocket located southeast of Richview TS. A single line diagram of this region is shown in Figure 3 below.

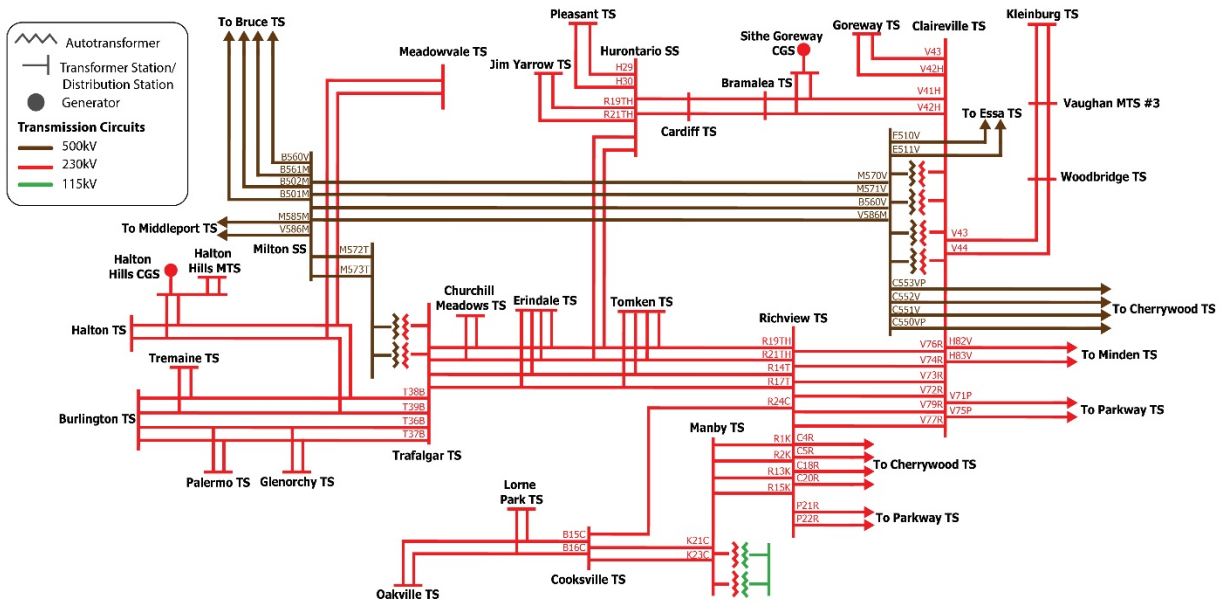

**Figure 3 | Single line diagram of the GTA West Region as depicted in the Needs Assessment Report (May 2019)**

## C.2 Scenarios Assessed

Table 5 below summarizes the scenarios assessed. Further details on the local generation assumptions, and interface flows are discussed in the subsequent subsections. Information on the load forecast is found in Appendix B above. Note that all scenarios assume peak summer load conditions consistent with the IRRP forecast.

**Table 5 | Summary of Scenarios Assessed**

Scenario	Local Generation	Interface Flows	Contingencies Assessed
A1	All I/S	95% of FETT all elements I/S TTC: 4890 MW Corresponds to ~ 1495 MW on RxT	N-1, N-2
A2	All I/S	95% of FETT one element O/S TTC: 3135 MW Corresponds to ~ 1075 MW on RxT	N-1-1
B	Halton Hills all units O/S	95% of FETT all elements I/S TTC: 4890 MW Corresponds to ~ 1495 MW on RxT	N-1, N-2
C	Goreway all units O/S	95% of FETT all elements I/S TTC: 4890 MW Corresponds to ~ 1495 MW on RxT	N-1, N-2

### C.2.1 Load Forecast

The initial need identification study used net peak summer forecast snapshots in 2020, 2025, 2030, and 2038 (end of planning horizon). The station level forecast is provided in Appendix B above.

A power factor of 0.93 at the load is used (without consideration for the status of low-tension capacitor banks<sup>4</sup>), so that approximately 0.9 power factor is observed at the Defined Metered Point.

### C.2.2 Local Generation Assumptions

Generation facilities are tabulated in Table 6. The base case used dependable generation (i.e., unforced capacity or “UCap”) as found in the Annual Planning Outlook and Reliability Outlook. Scenarios with Goreway/Halton Hills generation out of service was also studied. Note that distribution connected DG was already netted out in the load forecast (load modifier) based on summer peak contribution factors consistent with the Reliability Outlook.

**Table 6 | GTA West Generation Summary**

<b>Connection Type</b>	<b>Facility Name</b>	<b>Contract Capacity (MW)</b>	<b>Dependable Capacity (UCap, MW)</b>	<b>Term State Date</b>	<b>Term End Date</b>
Tx Connected	Goreway Station	839.1	833	04-Jun-2009	03-Jun-2029
Tx Connected	Halton Hills Generating Station	641.5	632	01-Sep-2010	31-Aug-2030
Dx Market Participants	GTAA Cogeneration Plant	90	See Footnote <sup>5</sup>	01-Feb-2006	31-Jan-2026
Dx Market Participants	Emerald Energy From Waste Facility	10.3	See Footnote	08-Sep-2015	31-May-2030
Dx DG	All Stations	87.2	Varies	Varies	Varies

<sup>4</sup> Low tension capacitor banks are often installed for the purpose of transmission system voltage control, and not power factor correction, and so, they are not considered for load power factor issues.

<sup>5</sup> After discussions with Alectra, these generators were treated as load modifiers. Their output is driven by GA avoidance behavior. Note that these generators need to be monitored to ensure station/circuit capacity is not exceeded if their behavior changes in the future.



### C.2.3 Major Interface Flows

The only major bulk interface in the GTA West region is FETT which is comprised of 3 'paths':

- (1) Orangeville x Essa - two 230 kV circuits (E8V, E9V)
- (2) Milton x Claireville, Bruce x Claireville, Middleport x Claireville – four 500kV circuits (M571V, M570V, B560V, V586M)
- (3) Trafalgar x Richview – four 230 kV circuits (R17T, R21TH, R14T, R19TH)

FETT flow levels can be distributed unevenly amongst these 3 paths depending on the drivers of the flow. A few observations on these 3 paths:

- Path (1) is outside of the GTA West region and electrically distant – it does not have any foreseeable impact on this study.
- Path (2) may have some impact on local reliability due to Claireville TS being a major supply point for this region, and contingencies involving this path can impact the underlying 230 kV system, which supplies the step-down stations delivering power to LDCs.
- Path (3) is directly part of the 230 kV 'backbone' for the GTA West region. Potential Trafalgar x Richview thermal issues as well as T38B/T39B and H29/H30 pocket overloads were flagged in the previous cycle of regional planning. Local reliability needs may be highly dependent on FETT flow levels along this path.
  - Although historical RxT flow is fairly low, future system changes such as Pickering/Lennox generation outages and Quebec import levels may increase the eastward flow along this path.

A FETT bulk study investigated possible interface reinforcements in anticipation of higher flow levels due to generation changes. The bulk study recommended that the RxT circuits be reconductored to increase their ampacity. Details about the recommendations were published by the IESO in December 2020<sup>6</sup>. The IRRP study aligned closely with the bulk study but focused solely on the impacts of local load growth on reliability.

The IRRP Basecase set FETT flow to 5% less than the calculated transfer capability from bulk study. The IRRP will use the TTC and nuclear generation dispatch consistent with Scenario #1<sup>7</sup> in the FETT bulk study which reflects the long term generation picture in the 2028-2035 timeframe.

In order to maintain a constant FETT flow in all IRRP forecast years, generation will be scaled both east and west of the FETT interface proportional to the load increase on each side. The intent of this procedure is to identify if local load growth alone causes any additional reliability needs.

---

<sup>6</sup> <https://www.ieso.ca/-/media/Files/IESO/Document-Library/planning-forecasts/FETT-upgrade-letter-to-Hydro-One-to-proceed-20201218.ashx>

<sup>7</sup> Bruce all units I/S; Darlington all units I/S; Pickering A all units O/S; Pickering B all units O/S

## C.3 System Topology

### C.3.1 Monitored Circuits and Sections

The primary supply points for the GTA West region are the 500/230 kV autotransformers at Trafalgar TS and Claireville TS. The 230 kV transmission system in GTA West is comprised of 3 main interconnected corridors with additional radial spurs:

- (1) Manby TS x Cooksville TS x Oakville TS towards the south
- (2) Richview TS x Trafalgar TS x Burlington TS running across the middle of the of the region
- (3) Claireville TS x Hurontario SS

Note that:

- Claireville TS 230 kV bus is split (breakers K1K2 and H1H2) due to short circuit limitations.
- Richview 230 kV bus is split due to potential safety limits until mitigation measures are implemented by Hydro One.

below list the monitored circuit sections in GTA West. Note that the 500kV circuits are not included.

**Table 7 | Monitored Circuits and Ratings**

Circuit	Section Number	From	To	Summer Ratings (A)		
				Cont	LTE	STE
B15C	1	Cooksville TS	Lorne Park TS	1290	1700	2090
B15C	2	Lorne Park TS	Ford JCT	1350	1800	2170
B15C	3	Ford JCT	Oakville TS #2	1350	1800	2170
B15C	4	Ford JCT	Ford Oakville CTS	840	1090	1210
B16C	1	Cooksville TS	Lorne Park TS	1290	1700	2090
B16C	2	Lorne Park TS	Ford JCT	1350	1800	2170
B16C	3	Ford JCT	Oakville TS #2	1350	1800	2170
B16C	4	Ford JCT	Ford Oakville CTS	840	1090	1210
H29	1	Hurontario SS	Pleasant TS	840	1090	1400
H30	1	Hurontario SS	Pleasant TS	840	1090	1400
K21C	3	Manby TS	Applewood JCT	1350	1800	2170
K21C	5	Applewood JCT	Cooksville TS	1558	0	5998
K21C	6	Cooksville TS	Cooksville TS	1290	1700	2090
K23C	1	Manby TS	Applewood JCT	1690	2120	2660
K23C	2	Applewood JCT	Cooksville TS	1290	1700	2090
K23C	3	Applewood JCT	Applewood JCT	1350	1800	2170

Circuit	Section Number	From	To	Summer Ratings (A)		
				Cont	LTE	STE
R14T	1	Richview TS	Tomken JCT	840	1090	1400
R14T	2	Tomken JCT	Erindale JCT	840	1090	1400
R14T	3	Erindale JCT	Trafalgar TS	1110	1460	2080
R14T	5	Erindale JCT	Erindale TS	1110	1460	1660
R14T	6	Tomken JCT	Tomken TS	870	1140	1440
R17T	1	Richview TS	Tomken JCT	840	1090	1400
R17T	2	Tomken JCT	Erindale JCT	840	1090	1400
R17T	3	Erindale JCT	Trafalgar TS	1110	1460	2080
R17T	5	Erindale JCT	Erindale TS	1110	1460	1660
R17T	6	Tomken JCT	Tomken TS	870	1140	1440
R19TH	1	Richview TS	Tomken JCT	840	1090	1400
R19TH	2	Tomken JCT	Hanlan JCT	840	1090	1400
R19TH	3	Hanlan JCT	Erindale JCT	840	1090	1400
R19TH	4	Erindale JCT	Churchill MeadowsJCT	1110	1460	2080
R19TH	5	Hanlan JCT	Hurontario SS	840	1090	1400
R19TH	6	Erindale JCT	Erindale TS	870	1140	1440
R19TH	7	Tomken JCT	Tomken TS	870	1140	1250
R19TH	8	Hurontario SS	Hurontario SS	840	1090	1400
R19TH	9	Hurontario SS	Jim Yarrow MTS	1290	0	7200
R19TH	10	Churchill MeadowsJCT	Trafalgar TS	1110	1460	2080
R19TH	11	Churchill MeadowsJCT	Churchill Meadows TS	1060	1400	1660
R21TH	1	Richview TS	Tomken JCT	840	1090	1400
R21TH	2	Tomken JCT	Hanlan JCT	840	1090	1400
R21TH	3	Hanlan JCT	Erindale JCT	840	1090	1400
R21TH	4	Erindale JCT	Churchill MeadowsJCT	1110	1460	2080
R21TH	5	Hanlan JCT	Hurontario SS	840	1090	1400
R21TH	6	Erindale JCT	Erindale TS	870	1140	1440
R21TH	7	Tomken JCT	Tomken TS	870	1140	1250
R21TH	8	Hurontario SS	Hurontario SS	840	1090	1400
R21TH	9	Hurontario SS	Jim Yarrow MTS	1290	0	7200
R21TH	10	Churchill MeadowsJCT	Trafalgar TS	1110	1460	2080
R21TH	11	Churchill MeadowsJCT	Churchill Meadows TS	1060	1400	1660
R24C	1	Richview TS	Applewood JCT	1690	2260	2930
R24C	2	Applewood JCT	Cooksville TS	1290	1700	2090
T36B	1	Trafalgar TS	Lantz JCT	1350	1800	2170
T36B	2	Palermo TxB JCT	Burlington TS	1110	1460	2080
T36B	3	Palermo TxB JCT	Palermo TS	840	1090	1400
T36B	4	Lantz JCT	Glenorchy JCT	1110	1460	2080
T36B	5	Lantz JCT	Trafalgar TS	1060	1400	1620
T36B	6	Glenorchy JCT	Palermo TxB JCT	1110	1460	2080
T36B	7	Glenorchy JCT	Glenorchy MTS #1	840	1090	1210

Circuit	Section Number	From	To	Summer Ratings (A)		
				Cont	LTE	STE
T37B	1	Trafalgar TS	Lantz JCT	1350	1800	2170
T37B	2	Palermo TxB JCT	Burlington TS	1110	1460	2080
T37B	3	Palermo TxB JCT	Palermo TS	840	1090	1400
T37B	4	Lantz JCT	Glenorchy JCT	1110	1460	2080
T37B	5	Lantz JCT	Trafalgar TS	1060	1400	1620
T37B	6	Glenorchy JCT	Palermo TxB JCT	1110	1460	2080
T37B	7	Glenorchy JCT	Glenorchy MTS #1	840	1090	1210
T38B	1	Trafalgar TS	Lantz JCT	1110	1460	2080
T38B	2	Lantz JCT	Tremaine JCT	1110	1460	2080
T38B	3	Lantz JCT	Trafalgar DESN JCT	1060	1400	1900
T38B	4	Hornby JCT	TCE Halton Hills JCT	1060	1400	1900
T38B	5	Hornby JCT	Meadowvale TS	1060	1400	1620
T38B	6	Trafalgar DESN JCT	Hornby JCT	1060	1400	1900
T38B	7	Trafalgar DESN JCT	Trafalgar TS	550	550	550
T38B	8	TCE Halton Hills JCT	Halton TS	1060	1400	1900
T38B	9	TCE Halton Hills JCT	TCE Halton Hills JCT	1900	2550	3400
T38B	12	Tremaine JCT	Burlington TS	1110	1460	2080
T38B	13	Tremaine JCT	Tremaine TS	1060	1400	1620
T39B	1	Trafalgar TS	Lantz JCT	1110	1460	2080
T39B	2	Lantz JCT	Tremaine JCT	1110	1460	2080
T39B	3	Lantz JCT	Trafalgar DESN JCT	1060	1400	1900
T39B	4	Hornby JCT	TCE Halton Hills JCT	1060	1400	1900
T39B	5	Hornby JCT	Meadowvale TS	1060	1400	1620
T39B	6	Trafalgar DESN JCT	Hornby JCT	1060	1400	1900
T39B	7	Trafalgar DESN JCT	Trafalgar TS	550	550	550
T39B	8	TCE Halton Hills JCT	Halton TS	1060	1400	1900
T39B	9	TCE Halton Hills JCT	TCE Halton Hills JCT	1900	2550	3400
T39B	12	Tremaine JCT	Burlington TS	1110	1460	2080
T39B	13	Tremaine JCT	Tremaine TS	1060	1400	1620
V41H	1	Claireville TS	Claireville TS	1550	1550	4850
V41H	2	Claireville TS	Sithe Goreway JCT	1370	1690	2060
V41H	3	Sithe Goreway JCT	Bramalea TS	1370	1690	2060
V41H	4	Bramalea TS	Cardiff JCT	1290	1700	2090
V41H	5	Cardiff JCT	Hurontario SS	1290	1700	2090
V41H	6	Sithe Goreway JCT	Sithe Goreway JCT	1490	1840	2200
V41H	8	Cardiff JCT	Cardiff TS	840	1090	1210
V42H	2	Claireville TS	Claireville TS	1550	1550	4850
V42H	3	Claireville TS	Sithe Goreway JCT	1370	1690	2060
V42H	4	Sithe Goreway JCT	Bramalea TS	1370	1690	2060
V42H	5	Bramalea TS	Cardiff JCT	1290	1700	2090
V42H	6	Cardiff JCT	Hurontario SS	1290	1700	2090

Circuit	Section Number	From	To	Summer Ratings (A)		
				Cont	LTE	STE
V42H	7	Sithe Goreway JCT	Sithe Goreway JCT	1490	1840	2200
V42H	9	Cardiff JCT	Cardiff TS	840	1090	1210
V42H	10	Claireville TS	Goreway JCT	1370	1820	2310
V42H	11	Goreway JCT	Goreway PH JCT	1060	1400	1620
V42H	12	Goreway PH JCT	Goreway TS	729	729	3477
V43	2	Claireville TS	Goreway JCT	1370	1820	2750
V43	3	Goreway JCT	Goreway PH JCT	1060	1400	1620
V43	4	Goreway PH JCT	Goreway TS	729	729	3477
V43	5	Claireville TS	Woodbridge JCT	1350	1800	2170
V43	6	Woodbridge JCT	Vaughan #3 JCT	1350	1800	2170
V43	7	Vaughan #3 JCT	Kleinburg TS	1370	1820	2750
V43	8	Woodbridge JCT	Woodbridge TS	840	1090	1210
V43	9	Vaughan #3 JCT	Vaughan MTS #3	840	1090	1210
V44	1	Claireville TS	Woodbridge JCT	1350	1800	2170
V44	2	Woodbridge JCT	Vaughan #3 JCT	1350	1800	2170
V44	3	Vaughan #3 JCT	Kleinburg TS	1370	1820	2750
V44	4	Woodbridge JCT	Woodbridge TS	840	1090	1210
V44	5	Vaughan #3 JCT	Vaughan MTS #3	840	1090	1210

### C.3.2 Special Protection Systems

Table 8 below shows the available special protection systems in the study region. These will be used first and foremost when any needs are identified by the studies.

**Table 8 | Relevant Special Protection Systems**

Facility	Description
Sithe-Goreway Generation Runback Scheme	<ul style="list-style-type: none"> <li>• Relieve the overloading of circuit V41H or V42H when a contingency occurs on the companion VxH circuit (either a line-end-open condition at Claireville TS or the loss of the circuit)</li> <li>• The scheme will runback total plant output to 645MW</li> <li>• Armed when there are post-contingency thermal concerns on V41H/V42H line sections</li> </ul>
VxH LEO Protection	<ul style="list-style-type: none"> <li>• Detects LEO conditions at Hurontario SS and Claireville TS line ends</li> <li>• VxH LEO protection logic:               <ul style="list-style-type: none"> <li>○ Hurontario sends a LEO signal to Claireville TS when breaker opens at Hurontario.</li> <li>○ At Claireville site, LEO is detected when (Hurontario LEO signal is received) AND (Claireville breakers open OR line disconnect opens) AND (line under voltage condition)</li> <li>○ If the above conditions are met for longer than 500ms, LEO will be asserted with drop out time of 35s to block auto reclose.</li> </ul> </li> <li>• This LEO will be combined with the traditional transfer trip sent to the other terminal stations (i.e. Hurontario and Sithe Goreway CGS) and the tapped DESN's (i.e. Bramalea and Cardiff)</li> </ul>
Manby TS Remedial Action System	<ul style="list-style-type: none"> <li>• Address post-contingency autotransformer overloading concerns at both Manby East and West</li> <li>• Load at remote DESN stations (John TS, Strachan TS, Fairbanks TS, Runnymede TS, Wiltshire TS) can be armed for Manby autotransformer contingencies</li> </ul>

---- End of Section ----

## C.4 Credible Planning Events and Criteria

### C.4.1 Studied Contingencies

Table 9 below shows the types of contingencies assessed and how they map to applicable standards. The table also specifies the amount of load rejection/curtailment allowed as per ORTAC.

(Table 9 on next page.)

**Table 9 | Types of Contingencies Assessed**

<b>Pre-contingency</b>	<b>Contingency<sup>8</sup></b>	<b>Type</b>	<b>Mapping to TPL/Directory 1 Event</b>	<b>Rating<sup>9</sup></b>	<b>Maximum Allowable Load Loss</b>
All elements in-service	None	N-0	P0	Continuous	None
All elements in-service	Single	N-1	P1, P2	LTE	150 MW by-configuration
All elements in-service	Double	N-2	P7, P4, P5	STE, reduced to LTE	150 MW lost by curtailment; 600 MW Total
All Transmission Elements in-service, local generation out-of-service, followed by system adjustments (Satisfy ORTAC 2.6 Re: local generation outage)	None	N-0	N/A	Continuous	None
Same as above	Single	N-1	P3	LTE	150 MW by-configuration; >0 MW lost by curtailment <sup>10</sup> ; Total 150 MW
Same as above	Double	N-2	N/A	STE, reduced to LTE	>150 MW lost by curtailment <sup>3</sup> ; 600 MW Total
Transmission element out-of-service, followed by system adjustments	Single	N-1-1	P6	STE, reduced to LTE	150 MW lost by curtailment; Total 600 MW

<sup>8</sup> Single contingency refers to a single zone of protection: a circuit, transformer, or generator. Double contingency refers to two zones of protection; the simultaneous outage of two adjacent circuits on a multi-circuit line, or breaker failure.

<sup>9</sup> LTE: Long-term emergency rating. 50-hr rating for circuits, 10-day rating for transformers.

STE: Short-term emergency rating. 15-min rating for circuits and transformers.

<sup>10</sup> Only to account for the magnitude of the generation outages



The tables below show the single, common tower, and breaker failure contingencies. Note that:

- Breaker failures and transformer failures that result in the same post-contingency state as the N-1 already documented are omitted.
- The outage events used for the N-1-1 studies are very similar to the N-1 contingencies documented in Table 10 but may be slightly different in some cases to reflect the fact that outages are the removal of a single element rather than all elements in a single zone of protection.
- Contingencies shown in *italics* are technically outside of the GTA West region definition but are included due to their proximity to the region and their potential impact to the performance of elements within the region.

**Table 10 | Studied N-1 Contingencies**

Contingencies						
B15C	B16C	H29C	H30C	K21C	K23C	R14T
R17T	R19TH	R21TH	R24C	T36B	T37B	T38B
T39B	V43	V44	V41H	V42H	Richview SC21	Manby E SC22
Manby W SC21	V72R	V73R	V74R	V76R	V77R	V79R
R1K	R2K	R13K	R15K	M570V	M571V	M572T
M573T	B560V	V586M				

**Table 11 | Studied N-2 Contingencies**

Contingencies							
B15C+	B16C	H29+	R14T+	R19TH+	T36B+	T38B+	V41H+
		H30	R17T	R21TH	T37B	T39B	V42H

V42H+V43	V43+V44	K21C/K23C	V72R+ V73R	V72R+ V79R	V73R+ V74R	V76R+ V77R
R1K+ R2K	R13K+ R15K	R13K+ R2K	Claireville HT13L74	Claireville HT13L83	Claireville HT14L43	Claireville HT14L79
Claireville HT15L44	Claireville HT15L73	Claireville HT16L72	Claireville HT16L75	Claireville L41L77	Claireville L42L76	Claireville L552L586
Claireville L553L560	Claireville L71L77	Claireville L76L82	Claireville PL586	Claireville W2L511	Claireville W2L550	Claireville W3L510
Claireville W3L570	Claireville W4L551	Claireville W4L571	Richview A1A2	Richview A1L14	Richview A1L17	Richview A1L74
Richview A1L77	Richview A2L19	Richview A2L21	Richview A2L24	Richview A2L73	Richview A2L76	Richview H1H2
Richview H1L21	Richview H1L4	Richview H1L5	Richview H1L79	Richview H2L18	Richview H2L20	Richview H2L22
Richview H2L72	Richview H2L76	Richview L17L79	Richview L18L73	Richview L19L22	Richview L20L21	Richview L21L77
Richview L24L72	Richview L4L74	Richview L5L14	Cooksville L15L21	Cooksville L15L24	Cooksville L16L23	Cooksville L16L24
Cooksville L21L23	Trafalgar HT15	Trafalgar K1K2	Trafalgar KL14	Trafalgar KL37	Trafalgar L14L38	Trafalgar L21L37
Trafalgar T14L36	Trafalgar T15L17	Hurontario L19L29	Hurontario L21L30	Hurontario L29L41	Hurontario L30L42	Burlington A1A2
Burlington A1L27	Burlington A1L38	Burlington A2L20	Burlington A2L25	Burlington A2L37	Burlington A2L41	Burlington H1H2

Burlington H1L28	Burlingt on H1L39	Burlington H2L18	Burlington H2L23	Burlington H2L36	Burlington H2L40	Burlington HT12L3
Burlington HT12L5	Burlingt on HT4L13	Burlington HT4L8	Burlington HT6L11	Burlington HT9L7	Burlington K1HT9	Burlington K1L4
Burlington K1L5	Burlingt on L10L12	Burlington L18L41	Burlington L20L36	Burlington L23L37	Burlington L25L40	Burlington L27WT4
Burlington L28L38	Burlingt on L4L6	Halton Hills HT1L38	Halton Hills HT1L39	Halton Hills HT2HT3	Halton Hills HT2L39	Halton Hills HT3L38
Manby East A2L1	Manby East A2L13	Manby East DK2	Manby East DL1	Manby East DL11	Manby East EK2	Manby East EL12
Manby East EL3	Manby East H2H3	Manby East H2L23	Manby East H3L13	Manby East L11L12	Manby East L1L23	Manby East L1L3
Manby West A1H4	Manby West A1L2	Manby West A1L22	Manby West H1H4	Manby West H1L15	Manby West H1L21	Manby West JL13
Manby West JL14	Manby West JL2	Manby West JL6	Manby West K1L13	Manby West K3L14	Manby West L2L21	Manby West PK1
Manby West PK3	Sithe Goreway T12L41	Sithe Goreway T12L42	M570V+ V586M	B560V+ M571V	M572T+ M573T	

#### C.4.2 Planning Criteria

The study will use the planning criteria in accordance with events and performance as detailed by:

- North American Electric Reliability Corporation (“NERC”) TPL-001 “Transmission System Planning Performance Requirements” (“TPL-001”), and

- IESO Ontario Resource and Transmission Assessment Criteria (“ORTAC”).

**---- End of Section ---**

## C.5 Study Result Findings

The following section describes the findings of the system studies. The results are presented under each applicable scenario as described in Table 5 above.

### C.5.1 Scenario A1 Findings

#### C.5.1.1 H29/H30 Supply Capacity Need

The study results show that a supply capacity need arises on the H29 and H30 circuits. The limiting phenomena is the loss of H29 or H30 resulting in the remaining companion circuit exceeding its LTE rating. This supply capacity need was also identified in the 2015 GTA West IRRP.

**Table 12 | H29/H30 Supply Capacity Need**

<b>Limiting Contingency</b>	<b>Limiting Element</b>	<b>From</b>	<b>To</b>	<b>LTE Rating [A]</b>	<b>2020 Loading [A]</b>	<b>2038 Loading [A]</b>
H29 or H30	H30 or H29	Hurontario SS	Pleasant TS	1090	925	1263

The identified LMC of the need is the same as that found in the 2015 GTA West IRRP; 417 MW. According to the forecast in Appendix B, this is expected to occur by 2027. For completeness, this need can also be found in all other scenarios.

#### C.5.1.2 T38B/T39B Load Security Need

Based on the load forecast in Appendix B there will be a load security need on the Halton Pocket starting in 2025. The Halton Pocket consists of stations served by the T38B and T39B circuits; namely Tremaine TS, Trafalgar DESN, Meadowvale TS, Halton TS, future Halton #2 TS and Halton Hills MTS. If a T38B + T39B contingency occur, these stations would be disconnected from the grid. As per ORTAC no more than 600 MW of load can be lost following the loss of two transmission elements. This 600 MW limit is exceeded in 2025 and is expected to grow to the end of the forecast. This need is demonstrated in Table 13 below. For completeness, this need can also be found in all other scenarios.

**Table 13 | T38B/T39B Load Security Need**

Limiting Contingency	Affected Stations	ORTAC Limit [MW]	2020 Load [MW]	2025 Load [MW]	2038 Load [MW]
T38B + T39B	Tremaine TS, Trafalgar DESN, Halton TS, Halton #2 TS, Halton Hills MTS, Meadowvale TS	600	520	602	775

## C.5.2 Scenario A2 Findings

### C.5.2.1 R19TH/R21TH Supply Capacity Need

This need occurs when H29 or H30 suffers a contingency following a V42H or V41H outage, respectively. As a result of the above outage + contingency combinations, the circuits R21TH or R19TH will be respectively overloaded. Based on the load forecast, it is expected that the LTE ratings of both R19TH and R21TH will be exceeded by summer 2021. Though not strictly a violation, operators will need to take action to reduce loading to below the LTE ratings within the time allowed by these ratings; in this case, 15 minutes. It is expected that the STE ratings will eventually be exceeded (which is a violation of ORTAC) by the end of the forecast period. This is demonstrated in Table 14 below.

**Table 14 | R19TH/R21TH Supply Capacity Need**

Contingency	Outage	Limiting Element	From	To	LTE Rating [A]	STE Rating [A]	2020 Loading [A]	2038 Loading [A]
H29 or H30	V42H or V41H	R21TH or R19TH	Hanlan JCT	Hurontario SS	1090	1400	1038	1451
H29 or H30	V42H or V41H	R21TH or R19TH	Hurontario SS	Hurontario SS	1090	1400	932	1283

## C.5.3 Scenario B Findings

### C.5.3.1 T38B/T39B Supply Capacity Need

This need occurs when Halton Hills GS is out of service. Due to the lack of generation, more power flows through T38B and T39B. As such, it is expected that, with Halton Hills GS out of service, the loss of T38B or T39B will result in its companion circuit exceeding LTE ratings. This can be seen in Table 15 below. The sections overloaded are a relatively short section of the circuits (approx. 400 meters in length).

The need is expected to start occurring in 2031. This will only increase as demand in the area is forecasted to grow throughout the study period.

**Table 15 | T38B/T39B Supply Capacity Need**

<b>Limiting Contingency</b>	<b>Limiting Element</b>	<b>From</b>	<b>To</b>	<b>LTE Rating [A]</b>	<b>2020 Loading [A]</b>	<b>2038 Loading [A]</b>
T38B or T39B	T39B or T38B	Lantz JCT	Trafalgar DESN JCT	1400	1021	1620

#### C.5.4 Scenario C Findings

There are no specific findings from Scenario C. All needs found in Scenario A1 are applicable in Scenario C as well.

#### C.6 Step Down Station Capacity Findings

This section identifies the step-down stations with capacity needs in the GTA West region. The affected step-down stations and the need years are identified below. Note that all stations identified grow beyond their station LTR once the forecast reaches the station LTR.

**Table 16 | Step Down Station Non-Coincident Capacity Needs**

<b>Station Forecast (MW)</b>	<b>Station LTR (MW)</b>	<b>2021</b>	<b>2030</b>	<b>2038</b>
Cardiff TS	114	102	119	125
Jim Yarrow MTS	157	129	154	169
Palermo TS	110	114	114	118
Tremaine TS	190	140	176	214

# Appendix D – Hourly Need Characterization

## D.1 T38B/T39B N-G-1 Thermal Need

**Table 17 | T38B/T39B N-G-1 Thermal Need Key Metrics**

Key Metrics	2030	2038
Pocket	Halton Pocket excluding Tremaine TS	
LMC	506 MW	
Capacity Need (MW)	0.1	64.5
Number of Events per Year	1	31
Maximum Energy per Event (MWh)	0.1	370.7
Maximum Event Length (Hours)	1	10
Average Event Length (Hours)	1.0	5.6
Total Energy (MWh)	0.1	3915.7

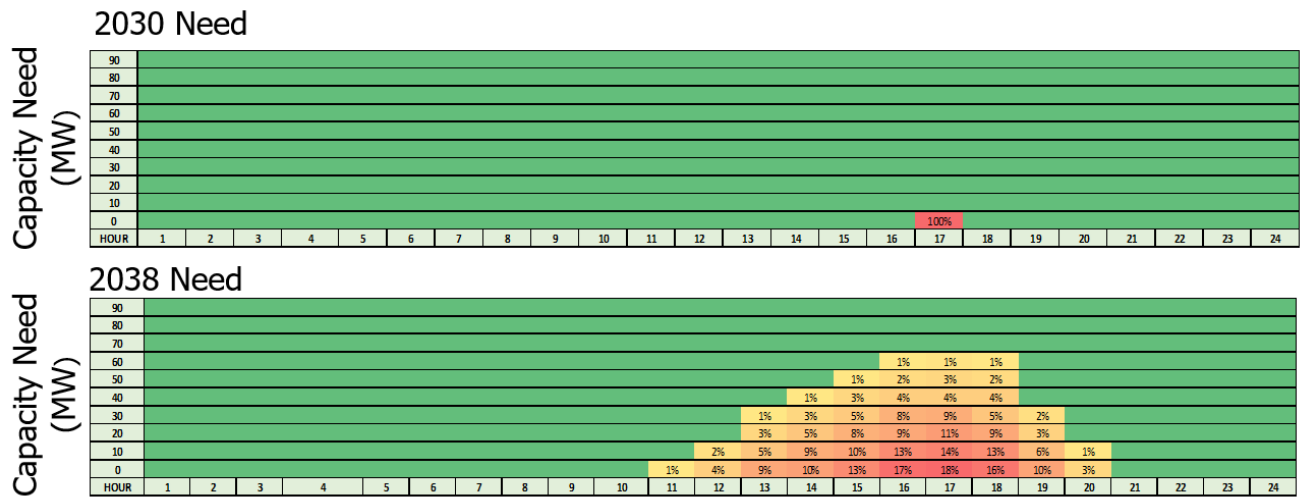

**Figure 4 | T38B/T39B N-G-1 Thermal Need Daily Heat Map (Percentage of Need Hours at or Above Megawatt Value)**



## D.2 R19TH/R21TH N-1-1 Thermal Need

**Table 18 | R19TH/R21TH N-1-1 Thermal Need Key Characteristics**

Key Metrics	2021	2038
Pocket	Pleasant Pocket	
LMC	368 MW	
Capacity Need (MW)	9.9	110.3
Number of Events per Year	2	24
Maximum Energy per Event (MWh)	9.9	693.2
Maximum Event Length (Hours)	1	12
Average Event Length (Hours)	1.0	5.3
Total Energy (MWh)	15.9	3154.4

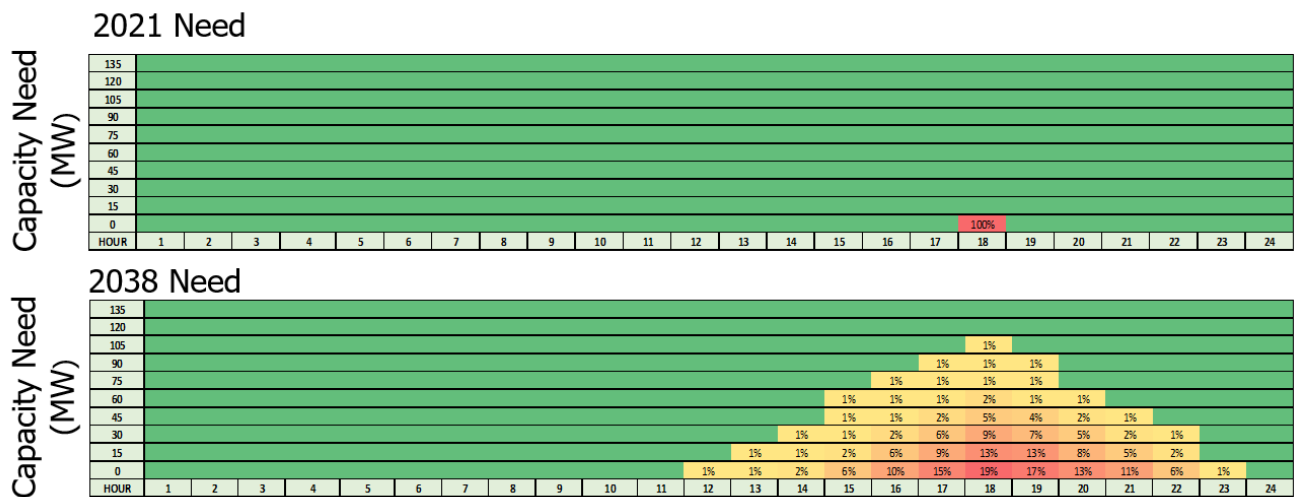
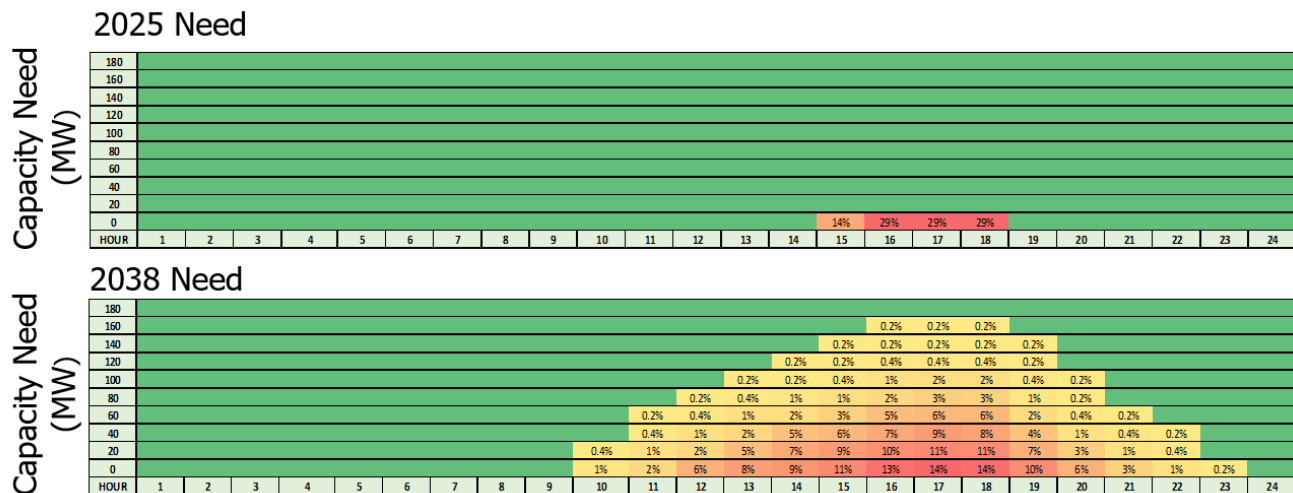

**Figure 5 | R19TH/R21TH N-1-1 Thermal Need Daily Heat Map (Percentage of Need Hours at or Above Megawatt Value)**

## D.3 T38B/T39B N-2 Load Security

**Table 19 | T38B/T39B N-2 Load Security Key Metrics**

Key Metrics	2025	2038
Pocket	Halton Pocket	
LMC	600 MW	
Capacity Need (MW)	9.0	170.0
Number of Events per Year	2	64
Maximum Energy per Event (MWh)	27.3	1481.1
Maximum Event Length (Hours)	4	14
Average Event Length (Hours)	3.5	7.0
Total Energy (MWh)	50.8	18340.9



**Figure 6 | T38B/T39B N-2 Load Security Daily Heat Map (Percentage of Need Hours at or Above Megawatt Value)**

## Appendix E – Economic Assumptions

The following is a list of the assumptions made in the economic analysis:

7. The NPV of the cash flows is expressed in 2020 CAD.
8. The USD/CAD exchange rate was assumed to be 0.78 for the study period.
9. Natural gas prices were assumed to be an average of \$4/MMBtu throughout the study period
10. The NPV analysis was conducted using a 4% real social discount rate. Sensitivities at 2% and 8% were performed. An annual inflation rate of 2% is assumed.
11. The life of the station upgrades was assumed to be 45 years; the life of the line was assumed to be 70 years; and the life of the SCGT generation and storage assets was assumed to be 30 years and 10 years respectively. The life of the storage asset was based 3600 cycles, which is assumed to be used to serve the local need first, and then global energy and ancillary services for the rest of the year. Cost of asset replacement were included where necessary to ensure the same NPV study period.
12. Development timelines for transmission was assumed to be 7 years; development timelines for generation and storage were assumed to be 3 years.
13. A SCGT was identified as one of the lowest-cost resource alternatives. The estimated overnight cost of capital assumed is about \$2000/kW (2020 CAD) depending on the unit size, based on escalating values from a previous study independently conducted for the IESO.<sup>11</sup>
14. An energy storage facility was identified as another low-cost resource alternative. Total energy storage system costs are composed of capacity and energy costs (I.e. energy storage devices are constrained by their energy reservoir). The estimated overnight cost of capital assumed is about \$900-\$1800/kW (2020 CAD) depending on the storage capacity to energy requirement, based on escalating Ontario-specific values from a previous study independently conducted for a collection of entities including the IESO.
15. Sizing of the storage solution was based on meeting the peak capacity and peak energy requirements for the local reliability need, such that the reservoir size is capable of using existing gas resources to sufficiently charge to meet the hours of unserved energy.

---

<sup>11</sup> Generally speaking, the most cost-effective transmission-connected options for meeting local needs in GTA West are resources with performance and costs on par with simple cycle gas turbines (SCGT) or combined cycle gas turbines (CCGT) generators depending on the relative size of the capacity versus energy requirements. New natural gas-fired generation was considered in the economic analysis for illustrative purposes to represent the cost of new generation.

16. System capacity value was \$128k/MW-yr (2020 CAD) based on an estimate for the Cost of the Marginal New Resource (Net CONE), a new SCGT in southwestern Ontario, with a sensitivity of +/- 25% assessed.
17. Production costs were determined based on energy requirements to serve the local reliability need, assuming fixed operating and maintenance costs of \$43/kW-yr for gas-fired resources and \$11/kW-yr for storage, and variable operating and maintenance costs of \$6/MWh and a heat rate of 9 MMBtu/MWh for gas-fired resources.
18. Carbon pricing assumptions are based on the proposed Federal carbon price increase, from \$50/t in 2022 to \$170/t by 2030, and applied to a facility's production.
19. The assessment was performed from an electricity consumer perspective and included all costs incurred by project developers, which were assumed to be passed on to consumers.

---

**Independent Electricity  
System Operator**

1600-120 Adelaide Street West  
Toronto, Ontario M5H 1T1

Phone: 905.403.6900

Toll-free: 1.888.448.7777

E-mail: [customer.relations@ieso.ca](mailto:customer.relations@ieso.ca)

**ieso.ca**

 [@IESO\\_Tweets](https://twitter.com/IESO_Tweets)

 [linkedin.com/company/IESO](https://www.linkedin.com/company/IESO)